

Zurcon® Wynseal M



Double-acting

Rubber-energized plastic-faced seal

Material:

Turcon®, Zurcon® and Elastomer





Zurcon® Wynseal M



Description

Zurcon® Wynseal M is a modified machined version, of the Zurcon® Wynseal design.

Wynseal M is a double-acting seal consisting of a Zurcon® or Turcon® seal ring and an O-Ring as energizing element – Figure 144.

The seal is designed with a seal edge profile. Two seal edges act as primary seal for pressures from both sides and prevent build-up of hydrodynamic pressure over the seal profile and the risk of blow-by effect. The central sealing and supporting rib increases the sealing effect*.

Radial notches are provided on both sides to provide activation of the energizing O-Ring. These ensure direct pressure loading of the seal under all operating conditions.

Installation groove is identical to that of Turcon® Glyd Ring® .

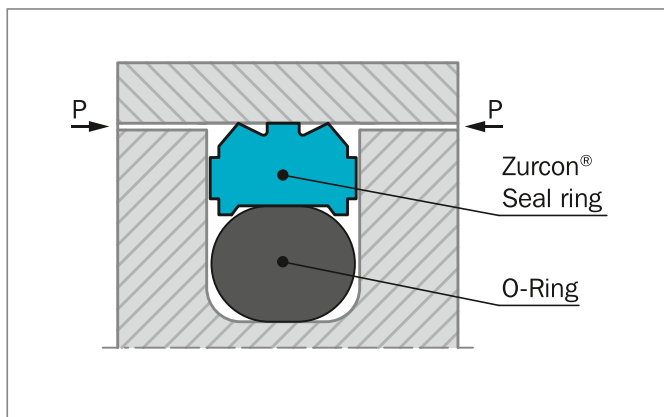

Figure 144: Zurcon® Wynseal M

* Only from PW62 and the following Series No.; PW60 is without seal edge profile and PW61 is without supporting rib.

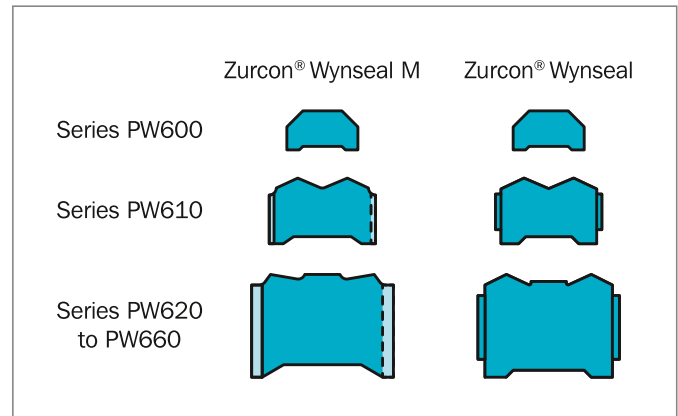

Figure 145: Zurcon® Wynseal M and Zurcon® Wynseal profiles

ADVANTAGES

- High static and dynamic sealing effect
- High abrasion resistance (Zurcon® materials)
- Simple groove design, one-piece piston possible
- Diameter range - from 8 to 2,700 mm
- Grooves according to ISO 7425-1
- Low friction
- Higher temperature (Turcon® materials)
- Higher pressure
- High chemical resistance

APPLICATION EXAMPLES

Zurcon® Wynseal M is used as double-acting piston seal for hydraulic components in applications such as:

- Machine tools
- Forklifts and handling machinery
- Agriculture
- Industrial hydraulics light to medium duty



OPERATING CONDITIONS

Pressure:	Up to 50 MPa
Speed:	Up to 10 m/s
Temperature:	-45 °C to +200 °C* depending on seal and O-Ring material
Media:	Mineral oil-based hydraulic fluids, flame retardant hydraulic fluids, environmentally friendly hydraulic fluids (bio-oils), phosphate ester, water and others, depending on temperature, seal and O-Ring material compatibility - see Table 135.
Clearance:	The maximum permissible radial clearance S_{max} is shown in Table 136, as a function of the operating pressure and functional diameter.

IMPORTANT NOTE

The above data are maximum values and cannot be used at the same time, e.g. the maximum operating speed depends on material type, pressure, temperature and gap value. Temperature range also depends on media.

* In the case of unpressurized piston applications in temperatures below 0 °C please contact your local Customer Solution Center for more information!

INSTALLATION INSTRUCTIONS

Wynseal® M is installed according to information on page 245 to page 249.

Closed groove installation according to dimensions in Table 81 page 249.

RECOMMENDED MATERIALS

The following material combinations have proven effective for hydraulic applications:

Wynseal M in Zurcon® Z54

For light to medium hydraulic applications with linear movements in mineral oils and other media with good lubrication:

O-Ring: NBR 70 Shore A N

Set code: Z54N

Wynseal M in Turcon® M12

All round material for light to heavy hydraulic applications linear, short stroke or helical movements in mineral oils, flame retardant hydraulic fluids, phosphate ester, bio-oils or fluids having low lubricating properties:

O-Ring: NBR 70 Shore A N
FKM 70 Shore A V

Set code: M12N or M12V

For specific applications, all Turcon® materials are available.

Other material combinations are listed in Table 135.

**Table 135: Turcon® and Zurcon® Materials for Wynseal M**

Material, Applications, Properties	Code	O-Ring Material Shore A	Code	O-Ring Operating Temp. * °C	Mating Surface Material	MPa max. Dynamic
Turcon® M12 First material choice for seals in linear motion Overall improved properties For new constructions and updating For all commonly applied hydraulic fluids including fluids with low lubrication performance Lowest friction and best sliding properties Lowest wear on seals Improved absorption of abrasive contaminants Low wear or abrasion of counter surface BAM tested Mineral fiber and Additives filled Color: Dark gray	M12	NBR 70	N	-30 to +100	Steel	35
		NBR 70 Low temp.	T	-45 to +80	Steel hardened Cast iron	
		FKM 70	V	-10 to +200	Stainless steel Titanium	
Turcon® T08 For lubricating fluids and linear motion Very high compressive strength and extrusion resistance Hard counter surfaces is recommended Bronze filled Color: Light to dark brown, which may have variations in shading	T08	NBR 70	N	-30 to +100	Steel hardened	50
		NBR 70 Low temp.	T	-45 to +80	Cast iron	
		FKM 70	V	-10 to +200		
Turcon® T40 For lubricating and non-lubricating fluids High frequency and short strokes Water hydraulics Surface texture is not suitable for gas sealing Carbon fiber filled Color: Gray	T40	NBR 70	N	-30 to +100	Steel	25
		NBR 70 Low temp.	T	-45 to +80	Steel hardened Cast iron	
		FKM 70	V	-10 to +200	Stainless steel Aluminum	
		EPDM 70	E**	-45 to +145		
Turcon® T46 For lubricated hydraulics in linear motion High compressive strength High extrusion resistance Very good sliding and wear properties BAM tested Bronze filled Color: Light to dark brown, which may have variations in shading	T46	NBR 70	N	-30 to +100	Steel hardened	35
		NBR 70 Low temp.	T	-45 to +80	Cast iron	
		FKM 70	V	-10 to +200		

Table continues on next page



Material, Applications, Properties	Code	O-Ring Material Shore A	Code	O-Ring Operating Temp.* °C	Mating Surface Material	MPa max. Dynamic
Zurcon® Z53*** For mineral oil based fluids Very high abrasion and extrusion resistance For counter surface with rougher surface finish Limited chemical resistance Max. working temperature 110 °C Cast polyurethane Color: Yellow to light-brown	Z53	NBR 70	N	-30 to +100	Steel	45
		NBR 70 Low temp.	T	-45 to +80	Steel hardened Cast iron Stainless steel Ceramic coating	
Zurcon® Z54*** For mineral oil based fluids Linear and slowly turning movements High abrasion resistance For counter surface with rougher surface finish Good extrusion resistance Limited chemical resistance Max. working temperature 110 °C Cast polyurethane Color: Turquoise	Z54	NBR 70	N	-30 to +100	Steel	25
		NBR 70 Low temp.	T	-45 to +80	Steel hardened Steel chrome plated (rod) Cast iron Stainless steel Ceramic coating	
Zurcon® Z80 For lubricating and non-lubricating fluids Water based fluids, air and gases Dry air pneumatics High abrasion and extrusion resistance For service in abrasive conditions and media with particles Good chemical resistance Limited temperature capability (-60 to +80 °C) UHMWPE (Ultra High Molecular Weight Polyethylene) Color: White to off-white	Z80	NBR 70	N	-30 to (+100)	Steel	30
		NBR 70 Low temp.	T	-45 to +80	Steel hardened Stainless steel	
		EPDM 70	E**	-45 to (+145)	Aluminum Bronze Ceramic coating	

* The O-Ring Operation Temperature is only valid in mineral hydraulic oil (except EPDM).

** Material not suitable for mineral oils.

*** Max. diameter 2,300 mm.

BAM: Tested by "Bundesanstalt Materialprüfung, Germany".

 Highlighted materials are recommended.



Installation Recommendation

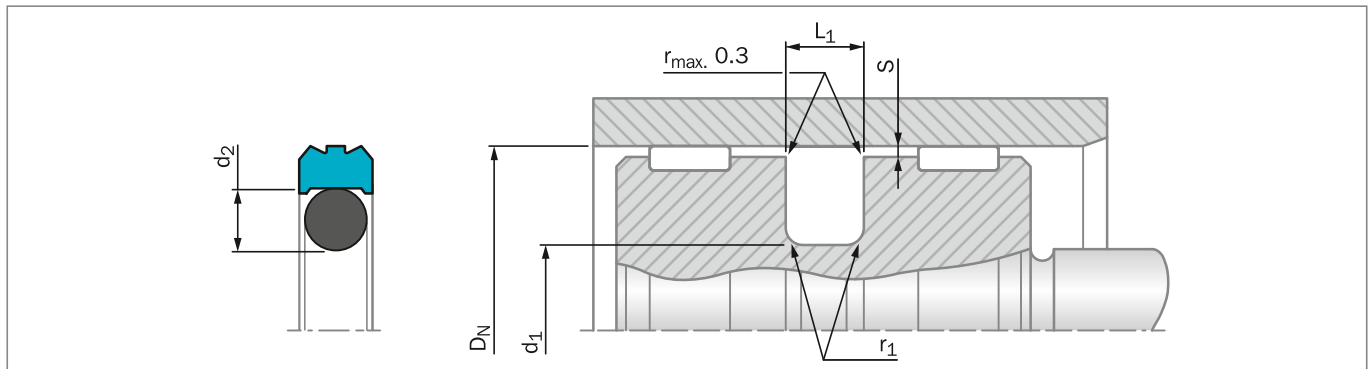

Figure 146: Installation Drawing

Table 136: Installation Dimensions – Standard Recommendations

Series No.	Bore Diameter D_N H9		Groove Diameter d_1 h9	Groove Width L_1 +0.2/-0	Radius r_1 max	Radial Clearance S_{max}^*			O-Ring Cross Section d_2
	Standard Application	Available Range				10 MPa	20 MPa	40 MPa	
PW600	8 - 14.9	8 - 140	$D_N - 4.9$	2.20	0.4	0.40	0.30	0.20	1.78
PW610	15 - 39.9	12 - 140	$D_N - 7.5$	3.20	0.6	0.60	0.50	0.30	2.62
PW620	40 - 79.9	15 - 320	$D_N - 11.0$	4.20	1.0	0.70	0.50	0.30	3.53
PW630	80 - 132.9	40 - 400	$D_N - 15.5$	6.30	1.3	0.80	0.60	0.40	5.33
PW640	133 - 329.9	80 - 700	$D_N - 21.0$	8.10	1.8	0.80	0.60	0.40	7.00
PW680	330 - 669.9	133 - 999.9	$D_N - 24.5$	8.10	1.8	0.90	0.70	0.50	7.00
PW650	670 - 999.9	330 - 999.9	$D_N - 28.0$	9.50	2.5	1.00	0.80	0.60	8.40
PW65X	1,000 - 1,200	-	$D_N - 28.0$	9.50	2.5	1.00	0.80	0.60	8.40
PW660**	-	670 - 999.9	$D_N - 38.0$	13.80	3.0	1.20	0.90	0.70	12.00
PW66X**	1,000 - 2,700***		$D_N - 38.0$	13.80	3.0	1.20	0.90	0.70	12.00

* At pressures > 40 MPa use diameter tolerance H8/f8 (bore/piston) in the area of the seal or consult your local Customer Solution Center for alternative material or profiles.

Slydring® / Wear Rings are not applicable at very small radial clearances please consult the Slydring® section in this catalog.

** O-Rings with 12 mm cross section are delivered as special profile ring.

*** Z53 and Z54 max diameter 2,300 mm.

ORDERING EXAMPLE

Zurcon® Wynseal M complete with O-Ring, standard application:

Series: PW630 from Table 136

Bore Diameter: $D_N = 80.0$ mm

TSS Part No.: PW6300800 from Table 137

Select the material from Table 135. The corresponding code numbers are appended to the TSS Part No. Together these form the TSS Article Number. The TSS Article Number for all intermediate sizes can be determined by following the example:

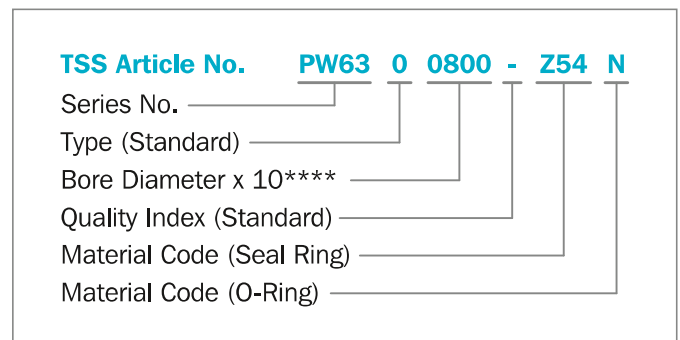

**** For diameters $D_N \geq 1,000.0$ mm multiply only by factor 1.
Example: PW66X for diameter $D_N = 1,200.0$ mm
TSS Article No.: PW66X1200 - Z54



Table 137: Installation Dimensions / TSS Part No.

Bore Dia.	Groove Dia.	Groove Width	TSS Part No.	O-Ring Dimensions	Bore Dia.	Groove Dia.	Groove Width	TSS Part No.	O-Ring Dimensions
D _N	d ₁	L ₁			D _N	d ₁	L ₁		
H9	h9	+0.2			H9	h9	+0.2		
8.0	3.1	2.2	PW6000080	2.90 x 1.78	70.0	59.0	4.2	PW6200700	56.74 x 3.53
10.0	5.1	2.2	PW6000100	4.80 x 1.80	70.0	54.5	6.3	PW6300700	53.34 x 5.33
12.0	7.1	2.2	PW6000120	6.70 x 1.80	75.0	64.0	4.2	PW6200750	63.09 x 3.53
14.0	9.1	2.2	PW6000140	8.75 x 1.80	75.0	59.5	6.3	PW6300750	56.52 x 3.53
15.0	7.5	3.2	PW6100150	7.59 x 2.62	80.0	69.0	4.2	PW6200800	66.27 x 3.53
16.0	11.1	2.2	PW6000160	10.82 x 1.78	80.0	64.5	6.3	PW6300800	62.87 x 5.33
16.0	8.5	3.2	PW6100160	7.59 x 2.62	80.0	59.0	8.1	PW6400800	58.00 x 7.00
18.0	13.1	2.2	PW6000180	12.42 x 1.78	85.0	69.5	6.3	PW6300850	69.22 x 5.33
18.0	10.5	3.2	PW6100180	9.19 x 2.62	85.0	64.0	8.1	PW6400850	63.00 x 7.00
20.0	15.1	2.2	PW6000200	14.00 x 1.78	90.0	79.0	4.2	PW6200900	78.97 x 3.53
20.0	12.5	3.2	PW6100200	12.37 x 2.62	90.0	74.5	6.3	PW6300900	72.39 x 5.33
22.0	17.1	2.2	PW6000220	17.17 x 1.78	90.0	69.0	8.1	PW6400900	68.00 x 7.00
22.0	14.5	3.2	PW6100220	13.94 x 2.62	95.0	84.0	4.2	PW6200950	82.14 x 3.53
24.0	16.5	3.2	PW6100240	15.54 x 2.62	95.0	79.5	6.3	PW6300950	78.74 x 5.33
25.0	20.1	2.2	PW6000250	18.77 x 1.78	95.0	74.0	8.1	PW6400950	73.00 x 7.00
25.0	17.5	3.2	PW6100250	17.12 x 2.62	100.0	89.0	4.2	PW6201000	88.49 x 3.53
25.0	14.0	4.2	PW6200250	13.87 x 3.53	100.0	84.5	6.3	PW6301000	81.92 x 5.33
28.0	20.5	3.2	PW6100280	20.29 x 2.62	100.0	79.0	8.1	PW6401000	78 x 7.00
30.0	22.5	3.2	PW6100300	21.89 x 2.62	105.0	94.0	4.2	PW6201050	91.67 x 3.53
32.0	27.1	2.2	PW6000320	26.70 x 1.78	105.0	89.5	6.3	PW6301050	88.27 x 5.33
32.0	24.5	3.2	PW6100320	23.47 x 2.62	110.0	99.0	4.2	PW6201100	98.02 x 3.53
32.0	21.0	4.2	PW6200320	20.22 x 3.53	110.0	94.5	6.3	PW6301100	91.44 x 5.33
35.0	27.5	3.2	PW6100350	26.64 x 2.62	110.0	89.0	8.1	PW6401100	88.00 x 7.00
35.0	24.0	4.2	PW6200350	23.40 x 3.53	115.0	99.5	6.3	PW6301150	97.79 x 5.33
36.0	28.5	3.2	PW6100360	28.24 x 2.62	120.0	109.0	4.2	PW6201200	107.54 x 3.53
38.0	30.5	3.2	PW6100380	29.82 x 2.62	120.0	104.5	6.3	PW6301200	100.97 x 5.33
40.0	32.5	3.2	PW6100400	31.42 x 2.62	120.0	99.0	8.1	PW6401200	98.00 x 7.00
40.0	29.0	4.2	PW6200400	28.17 x 3.53	125.0	114.0	4.2	PW6201250	113.89 x 3.53
42.0	31.0	4.2	PW6200420	29.75 x 3.53	125.0	109.5	6.3	PW6301250	107.32 x 5.33
45.0	34.0	4.2	PW6200450	32.92 x 3.53	125.0	104.0	8.1	PW6401250	103.00 x 7.00
48.0	37.0	4.2	PW6200480	36.09 x 3.53	130.0	114.5	6.3	PW6301300	113.67 x 5.33
50.0	42.5	3.2	PW6100500	40.94 x 2.62	130.0	109.0	8.1	PW6401300	108.00 x 7.00
50.0	39.0	4.2	PW6200500	37.70 x 3.53	135.0	114.0	8.1	PW6401350	113.67 x 7.00
50.0	34.5	6.3	PW6300500	32.69 x 5.33	140.0	124.5	6.3	PW6301400	123.19 x 5.33
52.0	41.0	4.2	PW6200520	40.87 x 3.53	140.0	119.0	8.1	PW6401400	116.84 x 7.00
55.0	44.0	4.2	PW6200550	44.04 x 3.53	150.0	134.5	6.3	PW6301500	132.72 x 5.33
56.0	45.0	4.2	PW6200560	44.04 x 3.53	150.0	129.0	8.1	PW6401500	126.37 x 7.00
60.0	49.0	4.2	PW6200600	47.22 x 3.53	160.0	144.5	6.3	PW6301600	142.24 x 5.33
63.0	52.0	4.2	PW6200630	50.39 x 3.53	160.0	139.0	8.1	PW6401600	135.89 x 7.00
63.0	47.5	6.3	PW6300630	46.99 x 5.33	170.0	149.0	8.1	PW6401700	145.42 x 7.00
65.0	54.0	4.2	PW6200650	53.57 x 3.53	180.0	164.5	6.3	PW6301800	164.47 x 5.33



Bore Dia.	Groove Dia.	Groove Width	TSS Part No.	O-Ring Dimensions
D _N	d ₁	L ₁		
H9	h9	+0.2		
180.0	159.0	8.1	PW6401800	158.12 x 7.00
190.0	169.0	8.1	PW6401900	164.47 x 7.00
200.0	184.5	6.3	PW6302000	183.52 x 5.33
200.0	179.0	8.1	PW6402000	177.17 x 7.00
210.0	189.0	8.1	PW6402100	183.52 x 7.00
220.0	199.0	8.1	PW6402200	196.22 x 7.00
230.0	214.5	6.3	PW6302300	208.92 x 5.33
230.0	209.0	8.1	PW6402300	208.92 x 7.00
240.0	219.0	8.1	PW6402400	215.27 x 7.00
250.0	229.0	8.1	PW6402500	227.97 x 7.00
250.0	225.5	8.1	PW6802500	215.27 x 7.00
250.0	134.5	6.3	PW6302500	234.32 x 5.33
260.0	239.0	8.1	PW6402600	240.67 x 7.00
270.0	249.0	8.1	PW6402700	240.67 x 7.00
280.0	259.0	8.1	PW6402800	253.37 x 7.00
290.0	269.0	8.1	PW6402900	266.07 x 7.00
300.0	279.0	8.1	PW6403000	278.77 x 7.00
300.0	275.5	8.1	PW6803000	266.07 x 7.00
320.0	299.0	8.1	PW6403200	291.47 x 7.00
320.0	295.5	8.1	PW6803200	291.47 x 7.00
350.0	325.5	8.1	PW6803500	316.87 x 7.00
360.0	335.5	8.1	PW6803600	329.57 x 7.00
380.0	355.5	8.1	PW6803800	354.97 x 7.00
400.0	375.5	8.1	PW6804000	367.67 x 7.00
450.0	425.5	8.1	PW6804500	417.96 x 7.00
500.0	475.5	8.1	PW6805000	468.76 x 7.00
600.0	575.5	8.1	PW6806000	557.66 x 7.00
700.0	672.0	9.5	PW6507000	670.00 x 8.40
780.0	752.0	9.5	PW6507800	750.00 x 8.40
800.0	772.0	9.5	PW6508000	770.00 x 8.40
900.0	872.0	9.5	PW6509000	870.00 x 8.40
1,000.0	972.0	9.5	PW65X1000	970.00 x 8.40
1,000.0	962.0	13.8	PW66X1000	960.00 x 12.00
1,200.0	1,172.0	9.5	PW65X1200	1,170.00 x 8.40
1,200.0	1,162.0	13.8	PW66X1200	1,160.00 x 12.00
1,500.0	1,462.0	13.8	PW66X1500	1,460.00 x 12.00
2,000.0	1,962.0	13.8	PW66X2000	1,960.00 x 12.00
2,700.0	2,662.0	13.8	PW66X2700	2,660.00 x 12.00

The bore diameters in **bold** type comply with the recommendations of ISO 3320. Other dimensions and all intermediate sizes up to 2,700 mm diameter including imperial (inch) sizes can be supplied.

All O-Rings with 12 mm cross section are delivered as special profile ring.