

BONDED SEALS U-SEALS

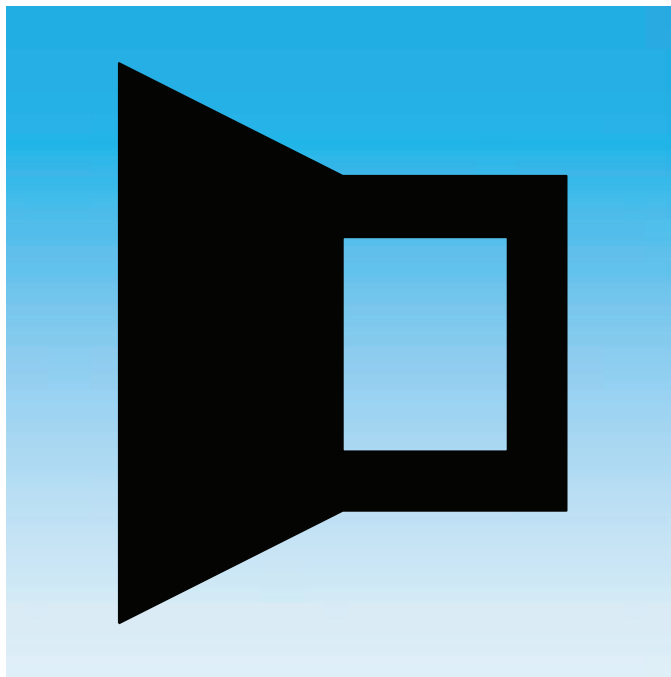

- Axial sealing -
- Rubber-metal Bonded Seals for bolted connections and mounting elements -





■ Description

Bonded Seals represent a combination of metal washer and elastomer sealing lip vulcanised to the edge of the metal part to seal bolted connections and mounting elements in all industrial applications e.g. pipe connections and couplings. When the bolted connection is tightened, the sealing lip is pressed against the flat surfaces.

The metal washer ensures that the components to be connected are reliably and securely held. The thickness of the washer limits the compression of the elastomer seal, eliminates any over torque of the joint, thereby ensuring a reliable sealing system. The internal pressure increases the sealing force by energising the sealing lip.

Advantages

- Cost effective solution for bolt/thread sealing
- Versatile, applicable to all threaded bolts, studs and clearance holes
- Sealing washers are available for metric, Whitworth and BSP threads
- Large range of elastomers and metals available
- Wide temperature range
- Reliable high and low pressure sealing
- Metall washer prevents over-compression and extrusion
- Usable for overhead installation
- Can be automatically installed
- Seals to plane surfaces with no housing for the sealing lip
- Visible from the outside
- No sweating
- Reusable
- Metal washer with vulcanised sealing body of rubber for sealing of bolt heads and flanges
- All European thread sizes available

■ GM500 / U-Seal

- Can be used to seal clearance or tapped holes in general engineering using a wide range of different bolts
- Can be used on flat flanges or with recessed bolt holes
- **Article group DD**

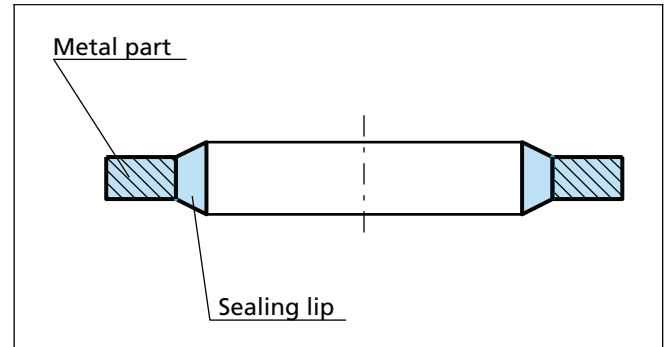

Figure 18 GM500 / U-Seal

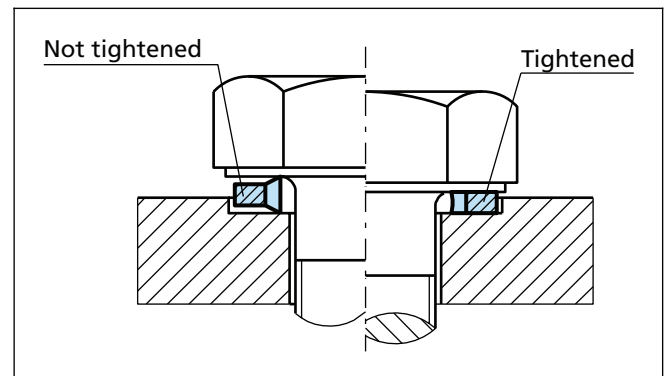

Figure 19 Installation GM500 / U-Seal



■ GM500 self-centering

- Centrally located
- Positively retained
- Ability to pre-assemble
- Ease of assembly
- All European thread sizes available
- **Article group DD**

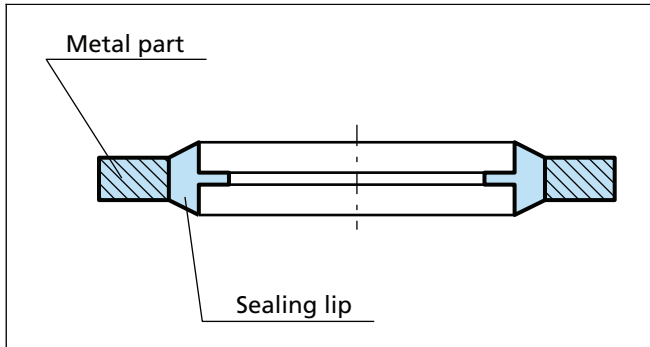

Figure 20 GM500 self-centering

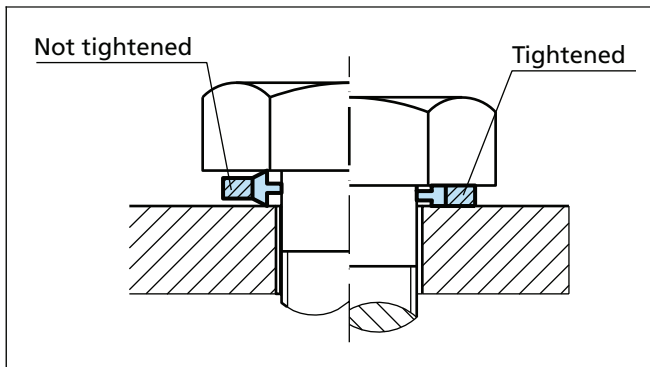

Figure 21 Installation GM500 self-centering

■ GM1000

- Good sealing function with a low tightening moment
- No need of a countersink to center the seal, this is achieved thanks to the design of the sealing lip
- Mostly used together with metric bolts with hexagonal heads as per DIN specifications
- On request GM 1000 can also be made for inch threads as well as for special bolts
- **Article group DDG1**

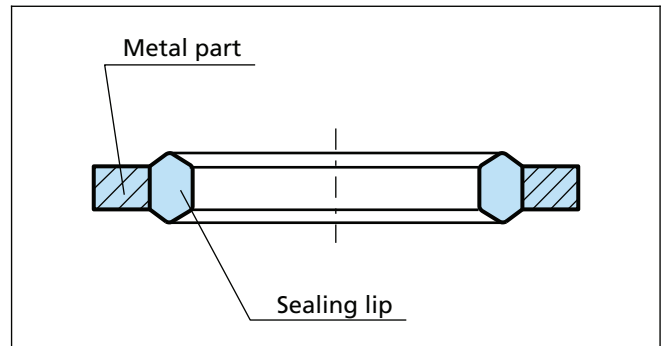

Figure 22 GM1000

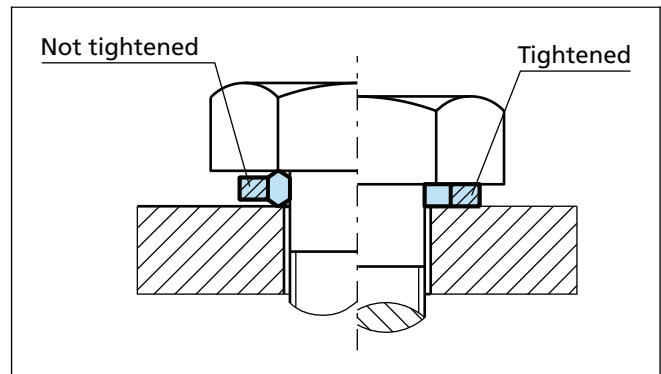

Figure 23 Installation GM1000



■ GM2000

- Rubber to metal bonded seal with specially designed sealing lip for threads and nuts
- No need of a countersink to center the seal, this is achieved thanks to the design of the sealing lip
- The seal prevents leakage by sealing in the thread
- The three contact lips of the rubber body seal the thread to nut and machine component
- Positively retained
- Mostly used together with hexagonal nuts as per DIN specification as well as for threaded connectors and adjusting screws

- Article group DDG2

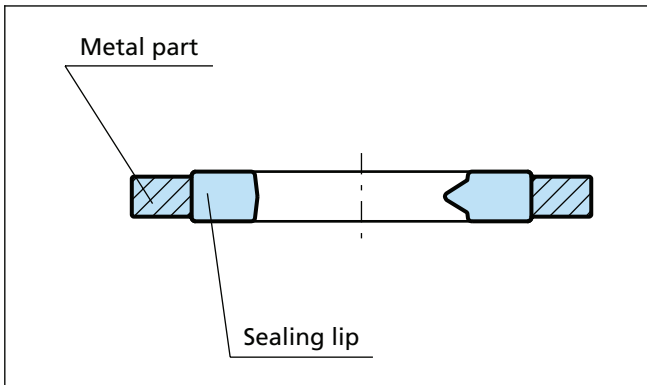

Figure 24 GM2000

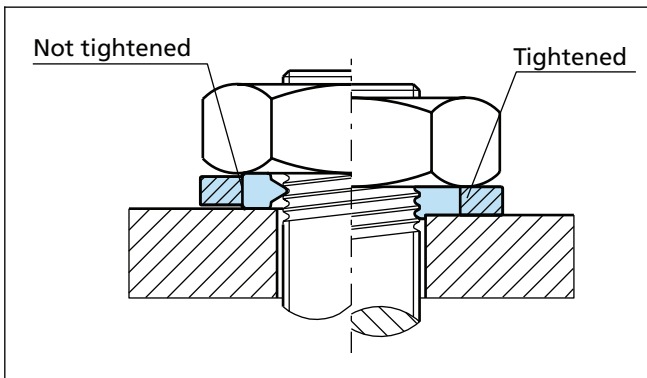

Figure 25 Installation GM2000



Figure 26 GM2000

■ GM3000 Sealing plate

Sealing plate GM3000 as per customer drawing and specification. The sealing lip is designed according to need and function. These sealing plates can in many applications very well replace O-Rings, square rings and moulded parts of rubber.

- One seal can seal multiple holes, flanges and such



Figure 27 GM3000

Design guidelines GM3000

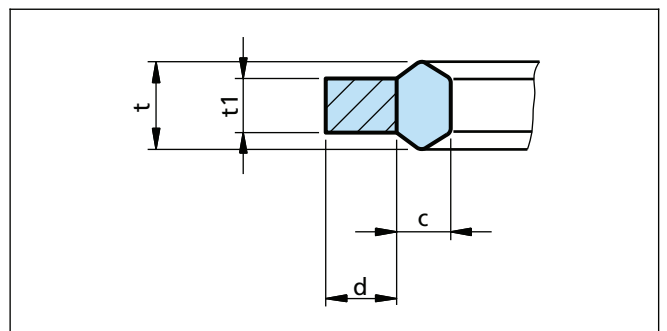

Figure 28 Sealing lip GM3000



Table XXIII Dimensions GM3000 (detail)

t1 ±0.15	t ±0.2	c ±0.2	d min.
1	1.5	1.4	1.25
1.25	1.85	1.6	1.5
1.5	2.25	1.8	1.75
2	2.6	2.5	2.25
2.5	3.15	3	2.75

Applications

- Flanges
- Plates
- Engines
- Bolts
- Valves
- Hydraulics
- Cylinder / valve connection

■ Seloc

- The shakeproof washer is well known for its ability to resist vibration, the effect of tightening the bolt or nut causing the metal serrations to pierce the rubber, bite into the relative metal surface and thus provide the necessary locking action. The cover or rubber reduces the risk of corrosion that would occur with normal lockwasher by enveloping the scores in the protective treatment on the metal face to give effective protection against moisture and oxidation.
- Resists vibrations
- Suitable for pre-build assemblies
- Options for water, mineral oils and alkalis
- Used on painted, plated and stove enamelled surfaces
- **Article group DDSL**

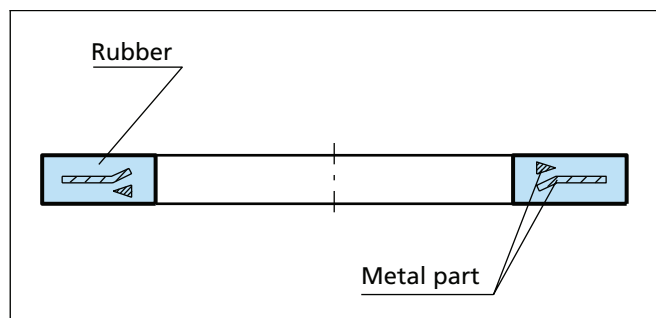

Figure 29 Seloc

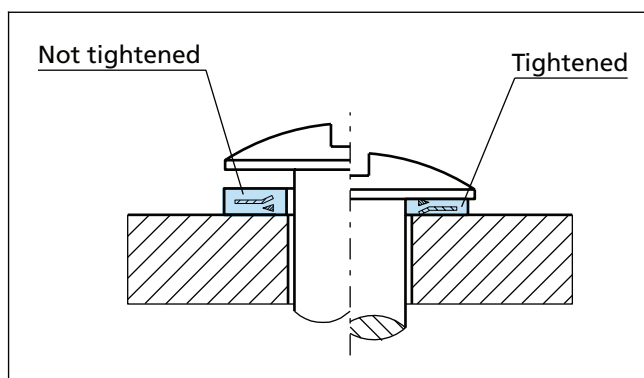

Figure 30 Installation Seloc

■ Technical data

Operating pressure

Max pressure is dependent of design, material choice and dimensions. Bonded Seals can be designed to withstand from 25 to 200 MPa max. pressure.

Please contact us for further information.

Operating temperature:

- 30 °C to + 100 °C NBR 70 Shore A
- 20 °C to + 100 °C NBR 90 Shore A
- 18 °C to + 200 °C FKM 70 Shore A / FKM 75 Shore
- 50 °C to + 120 °C EPDM 70 Shore A / EPDM 75 Shore
- 10 °C to + 80 °C NBR/PVC blend 60 Shore A

Media:

Mineral oils, water, water-oil emulsion, gases

Important Note:

Bonded Seals are not effective as a bolt locking device except Seloc. This must be taken into consideration particularly with bolted connections subject to dynamic loads.



■ Materials

GM500

Standard steel

- BS EN 10139: 1998 DC01 + C490
surface treatment zinc plate yellow chromate 8-12 µm

Stainless steel

- BS1449 (part2) type 316 (1.4436) (316S33)

Seal lip

- NBR 70 Shore A
- NBR 90 Shore A
- FKM 70 Shore A
- FKM 75 Shore A
- EPDM 75 Shore A

Other materials on request!

U-Seal

Standard steel

- 1.0330 (AISI 1008) surface treatment zinc plate yellow chromate

Stainless steel

- 1.4301 (AISI 304)

Seal lip

- NBR 70 Shore A
- FKM 70 Shore A

Other materials on request!

GM500 self centering

Standard steel

- BS1449 (part1) CS4 BR H5
surface treatment zinc plate yellow chromate 8-12 µm

Stainless steel

- BS1449 (part2) type 316 (1.4436) (316S33))

Seal lip

- NBR 70 Shore A
- NBR 90 Shore A
- FKM 70 Shore A
- FKM 75 Shore A
- EPDM 75 Shore A

Other materials on request!

GM1000 / GM2000

Standard steel

- SS1265-16 HB min 200 (St2K60)
surface treatment Fe/Zn 6c2 yellow chromate

Stainless steel

- SS2343 (AISI 316) (1.4436)

Seal lip

- NBR 70 Shore A
- FKM 70 Shore A
- EPDM 70 Shore A

Other materials on request!

GM3000 Sealing plate

Standard steel

- SS1265-16 HB min 200 (St2K60)
surface treatment Fe/Zn 6c4 black chromate
surface treatment Fe/Zn 6c2 yellow chromate
surface treatment Fe/Zn 6c1 blue chromate

Stainless steel

- SS2333 (AISI 304) (1.4301)

Aluminium

- SS4212 (EN AW-6082)

Brass

- SS5150 (ISO CuZn37)

Copper

- SS5015 (ISO Cu-DHP)

Seal lip

- NBR 70 Shore A
- FKM 70 Shore A

Other materials on request!

Seloc

Spring steel

Seal lip

- NBR/PVC blend 60 Shore A

Mating surfaces

The plane surfaces to be sealed should be free from scores and should be machined smooth. The permissible surface roughness is:

$$R_{\max} < 15 \mu\text{m}, R_a < 3.2 \mu\text{m}$$



Bonded Seals

Table XXIV Materials for Bonded Seals

Base material	Material code	Type					Seloc (DDSL)
		GM500 (DD)	U-Seal (DD)	GM500 self-centering (DD)	GM1000 (DDG1) GM2000 (DDG2)	GM3000	
NBR 70 Shore A + BS EN 10139: 1998	4N49	●	-	●	-	-	-
NBR 90 Shore A + BS EN 10139: 1998	4N59	●	-	●	-	-	-
FKM 70 Shore A + BS EN 10139: 1998	4V89	●	-	●	-	-	-
FKM 75 Shore A + BS EN 10139: 1998	4V49	●	-	●	-	-	-
EPDM 75 Shore A + BS EN 10139: 1998	4E49	●	-	●	-	-	-
NBR 70 Shore A + BS1449 (part2)	4N4E	●	-	●	-	-	-
NBR 90 Shore A + BS1449 (part2)	4N5E	●	-	●	-	-	-
FKM 70 Shore A + BS1449 (part2)	4V8E	●	-	●	-	-	-
FKM 75 Shore A + BS1449 (part2)	4V4E	●	-	●	-	-	-
EPDM 75 Shore A + BS1449 (part2)	4E4E	●	-	●	-	-	-
NBR 70 Shore A + 1.0330	N7MC	-	●	-	-	-	-
FKM 75 Shore A + 1.0330	VCBC	-	●	-	-	-	-
NBR 70 Shore A + 1.4301	N7MA	-	●	-	-	-	-
FKM 75 Shore A + 1.4301	VCBA	-	●	-	-	-	-
NBR 70 Shore A + SS1265	4N17	-	-	-	●	-	-
FKM 70 Shore A + SS1265	4V17	-	-	-	●	-	-
EPDM 70 Shore A + SS1265	4E17	-	-	-	●	-	-
NBR 70 Shore A + SS2343	4N15	-	-	-	●	-	-
FKM 70 Shore A + SS2343	4V15	-	-	-	●	-	-
NBR 70 Shore A + SS1265 black chromate	4N17M	-	-	-	-	●	-
NBR 70 Shore A + SS1265 yellow chromate	4N17Y	-	-	-	-	●	-
NBR 70 Shore A + SS1265 blue chromate	4N17L	-	-	-	-	●	-
FKM 70 Shore A + SS1265 black chromate	4V17M	-	-	-	-	●	-
FKM 70 Shore A + SS1265 yellow chromate	4V17Y	-	-	-	-	●	-
FKM 70 Shore A + SS1265 blue chromate	4V17L	-	-	-	-	●	-
NBR 70 Shore A + SS2333	4N12	-	-	-	-	●	-
FKM 70 Shore A + SS2333	4V12	-	-	-	-	●	-
NBR 70 Shore A + SS4212	4N1A	-	-	-	-	●	-
FKM 70 Shore A + SS4212	4V1A	-	-	-	-	●	-
NBR 70 Shore A + SS5150	4N1M	-	-	-	-	●	-
FKM 70 Shore A + SS5150	4V1M	-	-	-	-	●	-
NBR 70 Shore A + SS5015	4N1K	-	-	-	-	●	-
FKM 70 Shore A + SS5015	4V1K	-	-	-	-	●	-
NBR/PVC + Spring Steel	4NPH	-	-	-	-	-	●

● available - not available



Installation recommendations article group DD

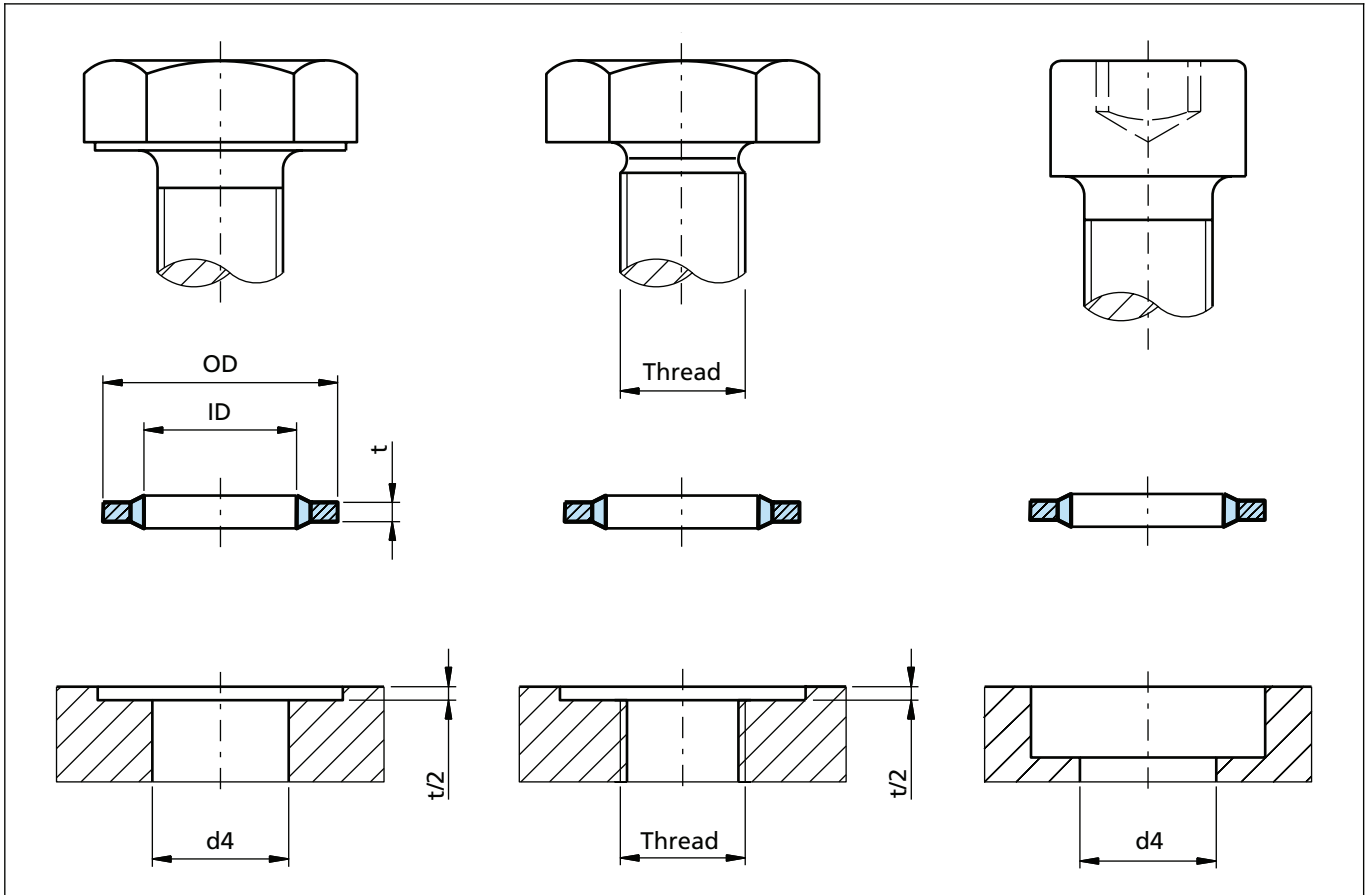

Figure 31 Installation drawing

Ordering example

Bonded Seal for hexagon head cap screw M4

Dimensions: Inside diameter ID = 4.5 mm
 Outside diameter OD = 7.0 mm
 Thickness t = 1.0 mm

Materials: Flat ring of steel (1.0330)
 Sealing lip of NBR 70 Shore A

Material code see page 90

TSS Article No.	DDM000045	-	N7MC
TSS Part No.			
Quality index (Standard)			
Material code (Standard)			



Bonded Seals

Table XXV GM500 / U-Seal Preferred metric dimensions

Metric thread	Dimensions			Bore	TSS Part No.	U-Seal	Ref. No. GM500
	ID	OD	t	d4			
M2.5	3.10	6.40	1.00	2.70	DDM000031	●	-
M2.5	3.10	6.40	1.30	2.70	DDM100031	●	-
M3	3.60	7.50	1.00	3.20	DDM000036	-	301
M3	4.10	7.00	1.00	3.20	DDM000041	●	-
M3 (M3.5)	4.10	7.20	1.00	3.20 (3.70)	DDM100041	●	201
M4	4.50	7.00	1.00	4.20	DDM000045	●	202
M4	4.60	9.00	1.00	4.30 (4.20)	DDM000046	●	302
M4	4.90	8.60	1.00	4.30	DDM000049	●	-
M5	5.60	10.00	1.00	5.20	DDM000056	-	303
M5	5.70	9.00	1.00	5.30 (5.20)	DDM000057	●	203
M5	5.70	9.20	1.00	5.30	DDM100057	●	-
M5	5.70	10.00	1.00	5.30 (5.20)	DDM200057	●	204
M5 (M5.5)	6.20	9.20	1.00	5.30 (5.70)	DDM000062	●	205
M6	6.60	11.00	1.00	6.20	DDM000066	-	304
M6	6.70	10.00	1.00	6.40 (6.20)	DDM000067	●	206
M6	6.70	11.00	1.00	6.40 (6.20)	DDM100067	●	207
M6	6.70	11.00	2.50	6.40 (6.20)	DDM200067	-	208
M6	6.85	13.27	1.30	6.20	DDM000068	-	305
M6	6.90	13.20	1.30	6.40	DDM000069	●	-
M6	7.00	11.40	1.00	6.20	DDM100070	-	306
M6	7.00	13.40	1.30	6.40	DDM000070	●	-
M6 (M6.5)	7.10	12.00	1.00	6.40 (6.70)	DDM000071	●	209
M6 (M6.7)	7.30	10.20	1.00	6.40 (6.90)	DDM000073	●	210
M6 (M8)	8.50	13.40	1.00	6.40 (8.20)	DDM000085	●	211
M8	8.60	13.00	1.00	8.20	DDM000086	-	307
M8	8.70	13.00	1.00	8.40 (8.20)	DDM000087	●	212
M8	8.70	14.00	1.00	8.40 (8.20)	DDM100087	●	213
M8	8.70	14.20	1.30	8.40	DDM200087	●	-
M8	8.70	16.00	1.00	8.40 (8.20)	DDM300087	●	214
M8 (M8.5)	9.30	13.30	1.00	8.40 (8.70)	DDM000093	●	215
M10	10.35	16.00	2.00	9.95	DDM000103	-	216
M8 (M10)	10.70	16.00	1.50	8.40 (10.20)	DDM000107	●	217
M10	10.70	17.00	1.50	10.20	DDM200107	-	310
M8 (M10)	10.70	18.00	1.50	8.40 (10.20)	DDM100107	●	218
M10 (M11)	11.40	16.30	1.50	10.50 (11.20)	DDM000114	●	219
M11	11.80	18.10	1.50	11.20	DDM200118	-	312

● Available sizes - Not available

Bonded Seals



Metric thread	Dimensions			Bore	TSS Part No.	U-Seal	Ref. No. GM500
	ID	OD	t	d4			
M10 (M11)	11.80	18.50	1.50	10.50 (11.20)	DDM000118	●	220
M10 (M11)	11.80	19.10	1.50	10.50 (11.20)	DDM100118	●	221
M10 (M12)	12.70	18.00	1.50	10.50 (12.20)	DDM000127	●	222
M12	12.70	19.00	1.50	12.20	DDM200127	-	313
M10 (M12)	12.70	20.00	1.50	10.50 (12.20)	DDM100127	●	223
M12 (M13)	13.70	20.00	1.50	13.00 (13.20)	DDM000137	●	224
M12	13.70	20.60	2.10	13.00	DDM100137	●	-
M12 (M13)	13.70	22.00	1.50	13.00 (13.20)	DDM200137	●	225
M12	13.70	22.20	1.59	13.00	DDM300137	●	-
M13	13.80	20.10	1.50	13.20	DDM000138	-	315
M12 (M13.5)	14.00	18.70	1.50	13.00 (13.70)	DDM000140	●	226
M14	14.70	21.00	1.50	14.20	DDM100147	-	316
M12 (M14)	14.70	22.00	1.50	13.00 (14.20)	DDM000147	●	227
M12	14.90	22.30	2.10	13.00	DDM000149	●	-
M14 (M15)	16.00	22.70	1.50	15.00 (15.20)	DDM000160	●	228
M14	16.50	25.50	2.10	15.00	DDM000165	●	-
M16	16.70	23.00	1.50	16.20	DDM100167	-	317
M14 (M16)	16.70	24.00	1.50	15.00 (16.20)	DDM000167	●	229
M16.5	17.20	23.90	2.10	16.70	DDM000172	-	319
M17	17.40	23.70	1.50	17.20	DDM200174	-	318
M14 (M17)	17.40	24.00	1.50	15.00 (17.20)	DDM000174	●	230
M14	17.40	24.00	2.00	15.00	DDM100174	●	-
M16 (M17.5)	18.00	24.70	1.50	17.00 (17.70)	DDM000180	●	231
M16	18.20	25.40	2.50	17.00	DDM000182	●	-
M16 (M18)	18.70	26.00	1.50	17.00 (18.20)	DDM000187	●	232
M18	18.70	27.00	2.00	18.20	DDM100187	-	320
M18 (M20)	20.70	28.00	1.50	19.00 (20.20)	DDM000207	●	233
M20	20.70	29.00	2.00	20.20	DDM100207	-	321
M18 (M21)	21.50	28.70	2.50	19.00 (21.20)	DDM000215	●	234
M21	21.70	30.00	2.00	21.20	DDM000217	-	323
M20 (M22)	22.50	28.00	1.50	21.00 (22.20)	DDM000225	●	235
M20 (M22)	22.70	30.00	2.00	21.00 (22.20)	DDM000227	●	236
M20 (M22)	22.70	30.00	3.00	21.00 (22.20)	DDM100227	●	237
M22	22.70	31.00	2.00	22.20	DDM200227	-	324
M23	23.70	32.00	2.00	23.20	DDM000237	-	325
M20 (M24)	24.70	32.00	2.00	21.00 (24.20)	DDM000247	●	238

● Available sizes - Not available



Bonded Seals

Metric thread	Dimensions			Bore	TSS Part No.	U-Seal	Ref. No. GM500
	ID	OD	t	d4			
M24	24.70	33.00	2.00	24.20	DDM100247	-	326
M22	26.70	35.00	2.00	23.00	DDM000267	●	-
M24	27.00	35.00	2.50	25.00	DDM000270	●	-
M26	27.00	35.30	2.00	26.20	DDM100270	-	327
M24 (M27)	27.20	36.00	2.00	25.00 (27.20)	DDM000272	●	240
M27	27.70	36.00	2.00	27.20	DDM000277	-	328
M28	28.60	36.00	2.00	28.20	DDM000286	-	329
M24	28.70	37.00	2.00	25.00	DDM000287	●	-
M28.5	29.20	37.50	2.00	28.70	DDM000292	-	330
M30	30.70	39.00	2.00	30.20	DDM000307	-	331
M27 (M30)	31.00	39.00	2.00	28.00 (30.20)	DDM000310	●	242
M27 (M33)	33.70	42.00	2.00	28.00 (33.20)	DDM000337	●	243
M27	33.90	42.80	3.25	28.00	DDM000339	●	-
M27	33.90	42.90	3.40	28.00	DDM100339	●	-
M30 (M33)	34.30	43.00	2.00	31.00 (33.20)	DDM000343	●	244
M30 (M36)	36.70	46.00	2.00	31.00 (36.20)	DDM000367	●	245
M36	37.00	48.00	2.50	36.20	DDM000370	-	333
M36 (M39)	40.00	51.00	2.50	37.00 (39.20)	DDM000400	●	246
M39	40.00	51.00	2.50	39.20	DDM100400	-	334
M36 (M42)	42.70	53.00	3.00	37.00 (42.20)	DDM000427	●	247
M42	43.00	54.00	2.50	42.20	DDM000430	-	335
M45	46.00	57.00	2.50	45.20	DDM000460	-	336
M36 (M48)	48.70	59.00	3.00	37.00 (48.20)	DDM000487	●	248
M48	49.00	60.00	2.50	48.20	DDM000490	-	337
M42	51.70	63.50	3.25	43.00	DDM000517	●	-
M42 (M51)	52.00	60.00	3.00	43.00 (51.20)	DDM000520	●	249
M48 (M52)	53.30	64.50	3.00	50.00 (52.20)	DDM000533	●	250
M48 (M60)	60.70	73.00	3.00	50.00 (60.20)	DDM000607	●	251
M68	68.60	79.50	3.50	68.20	DDM000686	-	252
M75	76.10	90.30	3.38	75.20	DDM100761	-	253
M64	76.10	90.30	3.40	66.00	DDM000761	●	-
M88	89.09	101.48	3.25	88.20	DDM000890	-	254
M125	127.00	143.67	5.00	125.20	DDM001270	-	255

● Available sizes - Not available

Bonded Seals



Table XXVI GM500 / U-Seal Preferred inch dimensions, BSP

Inch thread	BSP	Dimensions			Bore d4	TSS Part No.	U-Seal	Ref. No. GM500
		ID	OD	t				
6BA		3.05	6.35	1.22	2.79	DDW400001	-	001
1/8		3.70	8.05	1.04	3.50	DDW200005	●	-
9/64		4.00	8.38	1.04	3.90	DDW200006	●	-
4BA		4.12	7.26	1.22	3.60	DDW400002	-	002
5/32		4.70	9.29	1.04	4.50	DDW200008	●	-
2BA		5.21	8.38	1.22	4.69	DDW400003	-	003
3/16		5.60	10.79	1.37	5.40	DDW200190	●	-
7/32		6.20	11.55	1.37	6.00	DDW200216	●	-
1/4		6.86	13.21	1.22	6.34	DDW400004	-	004
1/4		6.99	13.34	1.22	6.35	DDW400005	-	005
1/4		7.10	13.18	1.37	7.00	DDW200250	●	-
5/16		8.31	13.34	1.22	7.93	DDW400006	-	006
5/16		8.64	14.22	1.22	7.94	DDW400007	-	007
5/16		8.70	15.16	1.37	8.50	DDW200312	●	-
3/8		10.30	17.52	1.37	10.20	DDW200375	●	-
3/8	1/8	10.37	15.88	2.00	9.53	DDW400020	-	020
40		11.26	18.36	2.00	10.16	DDW400008	-	008
7/16		11.69	19.05	2.00	11.11	DDW400009	-	009
7/16		11.90	19.53	1.90	11.70	DDW200437	●	-
1/2		13.70	22.30	1.90	13.50	DDW200500	●	-
1/2	1/4	13.74	20.57	2.00	12.70	DDW400021	-	021
9/16		14.86	22.23	2.00	14.28	DDW400010	-	010
9/16		15.30	24.68	1.90	15.00	DDW200562	●	-
60		15.83	22.23	2.00	15.23	DDW400022	-	022
5/8		16.52	25.40	2.00	15.88	DDW400011	-	011
5/8		16.90	27.05	1.90	16.80	DDW200625	●	-
	3/8	17.28	23.80	2.00	16.64	DDW400023	-	023
11/16		18.16	25.40	2.34	17.46	DDW400012	-	012
11/16		18.50	29.43	2.28	18.20	DDW200687	●	-
3/4		19.69	26.92	2.34	19.05	DDW400024	-	024
3/4		20.30	32.23	2.28	20.00	DDW200750	●	-
13/16	1/2	21.54	28.58	2.34	20.64	DDW400025	-	025
13/16		21.90	34.59	2.28	21.50	DDW200812	●	-
7/8	5/8	23.49	31.75	2.34	22.23	DDW400026	-	026
7/8		23.50	36.98	2.28	23.20	DDW200875	●	-
15/16		24.26	33.27	2.34	23.80	DDW400013	-	013

● Available sizes - Not available



Bonded Seals

Inch thread	BSP	Dimensions			Bore	TSS Part No.	U-Seal	Ref. No. GM500
		ID	OD	t				
15/16		25.10	38.96	2.28	24.80	DDW200937	●	-
1		26.70	42.13	2.28	26.50	DDW201000	●	-
1	3/4	27.05	34.93	2.34	25.41	DDW400027	-	027
1 1/16		27.82	38.61	2.34	27.00	DDW400028	-	028
1 1/8		29.33	36.58	2.34	28.57	DDW400014	-	014
1 1/8		29.80	46.91	2.28	29.50	DDW201125	●	-
1 3/16	7/8	30.81	38.10	2.34	30.15	DDW400029	-	029
1 1/4		32.64	41.40	3.25	31.74	DDW400015	-	015
1 1/4		33.00	51.28	3.40	32.80	DDW201250	●	-
1 5/16	1	33.89	42.80	2.34	33.33	DDW400031	-	031
1 5/16	1	33.89	42.80	3.25	33.33	DDW400030	-	030
1 3/8		35.94	44.45	3.25	34.92	DDW400016	-	016
1 1/2		38.96	47.75	3.25	38.10	DDW400017	-	017
1 1/2		39.50	58.93	3.40	39.00	DDW201500	●	-
1 5/8	1 1/4	42.93	52.38	3.25	41.29	DDW400032	-	032
1 3/4		45.34	57.15	3.25	44.44	DDW400018	-	018
1 7/8	1 1/2	48.44	58.60	3.25	47.64	DDW400033	-	033
2		51.69	63.50	3.25	50.79	DDW400019	-	019
2 1/8	1 3/4	54.89	69.85	3.25	53.99	DDW400034	-	034
2 1/4		58.04	70.36	3.25	57.14	DDW400035	-	035
	2	60.58	73.03	3.25	59.62	DDW400036	-	036
2 1/2		64.39	77.72	3.25	63.49	DDW400037	-	037
	2 1/4	66.68	79.50	3.25	65.50	DDW400038	-	038
	2 1/2	76.08	90.17	3.25	75.18	DDW400039	-	039

● Available sizes - Not available



Table XXVII GM500 Dimensions for pipe connections and couplings, ISO 1179

Thread dia. BSP	Dimensions			TSS Part No.
	ID +0.2	OD -0.2	t ± 0.15	
1/16	8.30	12.70	1.25	DDW400519
1/8	10.40	14.70	1.25	DDW400510
1/4	13.85	18.70	1.25	DDW400511
3/8	17.35	22.70	1.25	DDW400512
1/2	21.65	26.70	1.25	DDW400513
3/4	27.30	32.50	1.25	DDW400514
1	34.20	39.50	2.00	DDW400515
1 1/4	42.80	49.50	2.00	DDW400516
1 1/2	48.70	55.50	2.00	DDW400517
2	60.50	68.50	2.00	DDW400518



Bonded Seals

GM 500 Self-centering

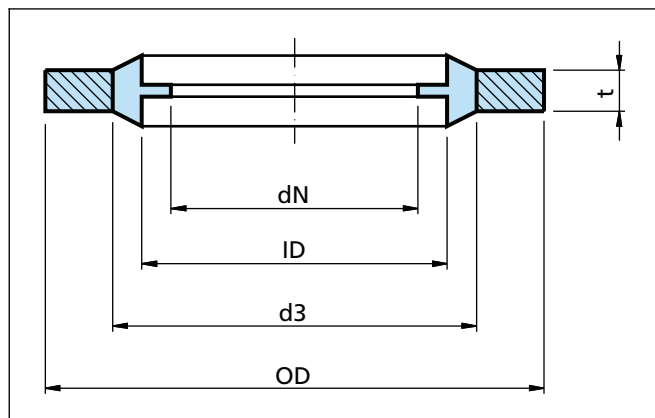

Figure 32 GM500 Self-centering

Ordering example

M8

TSS Article No.: DDM0C0087-4V4E

Material code see page 90

Table XXVIII GM500 Self-centering range metric dimensions

Metric thread	Dimensions					TSS Part No.
	OD	d3	ID	dN	t	
M4	7.00	5.40	4.50	3.30	1.00	DDM0C0045
M5	10.00	7.40	5.70	4.45	1.00	DDM0C0057
M6	10.00	8.00	6.70	5.60	1.00	DDM0C0067
M8	14.00	10.40	8.70	6.40	1.00	DDM0C0087
M10	16.00	12.40	10.70	8.05	1.50	DDM0C0107
M12	19.00	14.10	12.70	9.73	1.50	DDM0C0127
M14	22.00	16.40	14.70	11.38	1.50	DDM0C0147
M16	24.00	18.40	16.70	13.41	1.50	DDM0C0167
M18	26.00	20.40	18.70	14.76	1.50	DDM0C0187
M20	28.00	22.50	20.70	16.76	1.50	DDM0C0207
M22	30.00	24.40	22.70	18.74	2.00	DDM0C0227
M24	32.00	26.40	24.70	20.11	2.00	DDM0C0247



Ordering example

BSP 3/8

TSS Article No.: DDW4C0823-4N5E

Material code see page 90

Table XXIX GM500 Self-centering range inch dimensions, BSP

Inch thread	Dimensions					TSS Part No.
	OD	d3	ID	dN	t	
BSP 1/8	15.88	11.84	10.37	8.26	2.00	DDW4C0820
BSP 1/4	20.57	15.21	13.74	11.18	2.00	DDW4C0821
5/8	25.40	18.75	16.51	12.90	2.00	DDW4C0869
BSP 3/8	23.80	18.75	17.28	14.76	2.00	DDW4C0823
11/16	25.40	19.69	18.16	14.50	2.40	DDW4C0871
BSP 1/2	28.58	23.01	21.54	18.24	2.47	DDW4C0825
BSP 5/8	31.75	24.97	23.49	20.27	2.47	DDW4C0826
BSP 3/4	34.93	28.53	27.05	23.83	2.47	DDW4C0827
BSP 7/8	38.10	32.29	30.81	27.51	2.47	DDW4C0829
BSP 1	42.80	36.88	33.89	29.92	3.40	DDW4C0830
BSP 1 1/4	52.38	45.93	42.93	38.45	3.40	DDW4C0832
BSP 1 1/2	58.60	51.39	48.44	44.45	3.40	DDW4C0833
BSP 1 3/4	69.85	58.30	54.89	50.42	3.40	DDW4C0834
BSP 2	73.03	63.63	60.58	56.26	3.40	DDW4C0836
BSP 2 1/4	79.50	69.98	66.68	62.36	3.40	DDW4C0838
BSP 2 1/2	90.17	79.38	76.08	71.50	3.40	DDW4C0839



Bonded Seals

GM1000

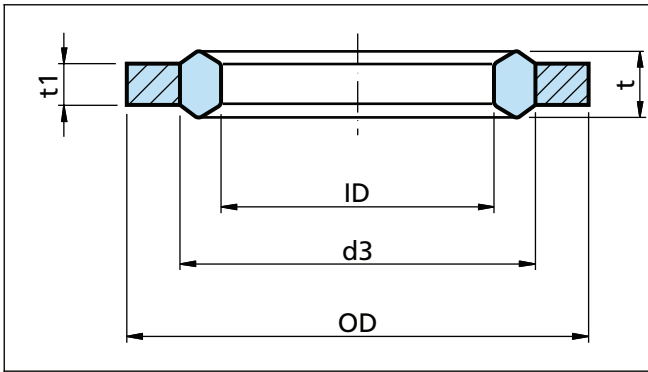

Figure 33 GM1000

Ordering example

M12

TSS Article No.: DDG100M12-4V17

Material code see page 90

Table XXX GM1000 metric dimensions

Metric thread	ø OD	Tol ±	ø d3	ø ID	Tol ±	t	Tol ±	t1	Tol ±	Clearance bore max ø	TSS Part No.
M 3	5.9	0.20	4.50	3.0	0.2	1.40	0.20	1.0	0.15	3.6	DDG100M3
M 4	7.9	0.20	6.00	4.0	0.2	1.50	0.20	1.0	0.15	4.5	DDG100M4
M 5	8.9	0.20	6.40	5.0	0.2	1.50	0.20	1.0	0.15	5.5	DDG100M5
M 6	9.9	0.20	8.00	6.0	0.2	1.50	0.20	1.0	0.15	6.6	DDG100M6
M 8	13.9	0.20	11.00	8.0	0.2	2.00	0.20	1.0	0.15	9.0	DDG100M8
M 10	16.9	0.35	13.00	10.0	0.25	2.50	0.20	1.5	0.15	11.0	DDG100M10
M 12	18.9	0.35	16.00	12.0	0.25	2.50	0.20	1.5	0.15	14.0	DDG100M12
M 14	21.9	0.35	18.00	14.0	0.25	2.50	0.20	1.5	0.15	16.0	DDG100M14
M 16	23.9	0.35	20.00	16.0	0.25	2.50	0.20	1.5	0.15	18.0	DDG100M16
M 18	26.9	0.40	22.00	18.0	0.35	3.00	0.20	2.0	0.15	20.0	DDG100M18
M 20	29.9	0.40	25.00	20.0	0.35	3.00	0.20	2.0	0.15	22.0	DDG100M20
M 22	31.9	0.40	27.00	22.0	0.35	3.00	0.20	2.0	0.15	24.0	DDG100M22
M 24	35.9	0.40	29.00	24.0	0.35	3.00	0.20	2.0	0.15	26.0	DDG100M24



GM2000

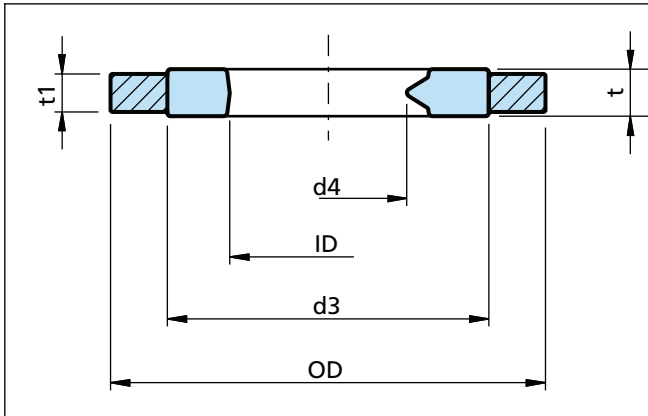

Figure 34 GM2000

Ordering example

M6

TSS Article No.: DDG2000M6-4N17

Material code see page 90

Table XXXI GM2000 metric dimensions

Metric thread	\varnothing OD	Tol \pm	\varnothing d3	\varnothing ID	Tol \pm	t	Tol \pm	t1	Tol \pm	\varnothing d4	Bore max \varnothing	Pitch of thread	TSS Part No.
M 4	7.9	0.20	6.0	4.2	0.20	1.8	0.30	1.0	0.15	3.1	4.3	0.70	DDG2000M4
M 5	8.9	0.20	6.4	5.2	0.20	1.8	0.30	1.0	0.15	4.0	5.3	0.80	DDG2000M5
M 6	9.9	0.20	8.0	6.2	0.20	1.8	0.30	1.0	0.15	4.7	6.4	1.00	DDG2000M6
M 8	13.9	0.20	11.0	8.2	0.20	2.5	0.30	1.5	0.15	6.4	8.4	1.25	DDG2000M8
M 10	16.9	0.35	13.0	10.2	0.25	2.5	0.30	1.5	0.15	8.1	10.5	1.50	DDG2000M10
M 12	18.9	0.35	15.0	12.2	0.25	2.5	0.30	1.5	0.15	9.8	13.0	1.75	DDG2000M12
M 14	21.9	0.35	18.0	14.2	0.25	3.0	0.30	2.0	0.15	11.5	15.0	2.00	DDG2000M14
M 16	23.9	0.35	20.0	16.2	0.25	3.5	0.30	2.5	0.15	13.5	17.0	2.00	DDG2000M16
M 18	26.9	0.40	22.0	18.2	0.35	3.5	0.30	2.5	0.15	14.8	19.0	2.50	DDG2000M18
M 20	29.9	0.40	25.0	20.2	0.35	3.7	0.30	2.5	0.15	16.8	21.0	2.50	DDG2000M20
M 22	31.9	0.40	27.0	22.2	0.35	3.7	0.30	2.5	0.15	18.8	23.0	2.50	DDG2000M22
M 24	35.9	0.40	29.0	24.2	0.35	4.2	0.30	3.0	0.15	20.2	25.0	3.00	DDG2000M24



Bonded Seals

Seloc

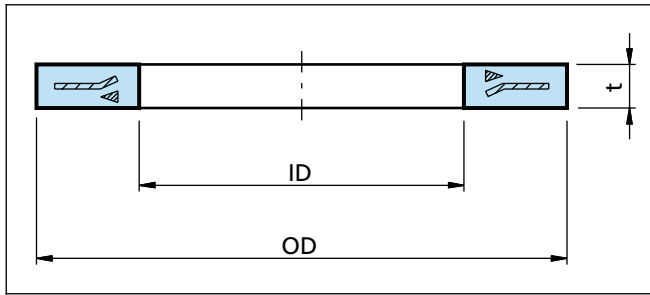

Figure 35 Seloc

Ordering example

M3, 4BA, 6UNC

TSS Article No.: DDSL00002-4NPH

Material code see page 90

Table XXXII Seloc dimensions

Inch thread	Metric thread	Dimensions			TSS Part No.
		ID	OD	t	
6BA, 4UNC	M2.5; M2.6	3.05	7.62	1.27	DDSL00001
4BA, 6UNC	M3	3.81	8.64	1.27	DDSL00002
3BA, 8UNC	M3.5; M4	4.32	10.16	1.40	DDSL00003
2BA, 3/16in	M4	4.95	11.18	1.52	DDSL00004
1/4	M6	6.60	13.34	1.78	DDSL00005
5/16	M8	8.26	16.26	1.78	DDSL00006
3/8	M9	9.78	18.54	2.03	DDSL00007
7/16	M10	11.38	21.00	2.29	DDSL00008
1/2	M12	13.08	23.37	2.29	DDSL00009
9/16	M14	14.73	25.65	2.29	DDSL00010
5/8	M16	16.26	28.19	2.54	DDSL00011
3/4	M18	19.43	32.90	2.67	DDSL00012
7/8	M22	22.86	36.58	2.79	DDSL00013
1	M24	26.29	42.55	3.05	DDSL00014