

# Turcon® AQ-Seal® 5



---

Double-acting

---

Rubber-energized plastic-faced seal

**Material:**

Turcon®, Zurcon® and Elastomer

---







## ■ Turcon® AQ-Seal® 5\*



### ■ Description

Turcon® AQ-Seal® 5 is a patented development of the proven standard Turcon® AQ-Seal®.

The particular characteristics of AQ-Seal® 5 are the seal profile with a defined seal edge and the use of two O-Rings as energizing elements to optimize the pressure profile and to reduce gas permeability.

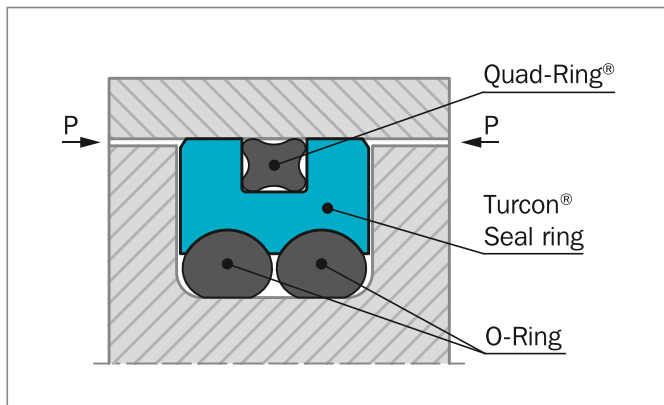

Figure 117: Turcon® AQ-Seal® 5

AQ-Seal® 5 combines the benefits of a low-friction Turcon® slipper seal with the high sealing characteristics of an elastomeric seal by incorporating a limited footprint Quad-Ring® Seal in the dynamic sealing face. This optimizes leakage control while minimizing friction.

### ADVANTAGES

- High sealing effect in applications requiring media separation, e.g. fluid/fluid or fluid/gas
- Double security through the combination of low-friction special materials with elastomer seals
- Low gas permeation rate
- Higher pressure application, higher sliding speed compared to AQ-Seal®
- Outstanding sliding properties, no stick-slip effect
- Diameter from 25 to 700 mm (for sizes above use Turcon® AQ-Seal® 5 with Bean Seal, see page 431)

\* Patent No. EP 0 424 372

### APPLICATION EXAMPLES

Turcon® AQ-Seal® 5 is mainly designed for heavy duty and large diameter applications and is recommended as double acting piston seal for hydraulic equipment such as:

- Mobil hydraulics
- Cranes
- Stabilizers
- Heavy duty suspension cylinders
- Hydro-pneumatic suspensions for heavy vehicles
- Machine tools
- Presses
- Rolling mills
- Servo hydraulics
- Offshore equipment
- Cylinders with retaining function over longer periods such as jacks and support cylinders



### OPERATING CONDITIONS

<b>Pressure:</b>	Up to 60 MPa with mineral oil Up to 25 MPa for media with low lubricating properties
<b>Speed:</b>	Up to 3 m/s with linear movements frequency up to 3 Hz
<b>Temperature:</b>	-30 °C to +200 °C* depending on seal, O-Ring and Quad-Ring® material
<b>Media:</b>	Mineral oil-based hydraulic fluids, flame retardant hydraulic fluids, environmentally friendly hydraulic fluids (bio-oils), phosphate ester, water and others, depending on temperature, seal, O-Ring and Quad-Ring® seal material compatibility see Table 99
<b>Clearance:</b>	The maximum permissible radial clearance $S_{max}$ is shown in Table 100, as a function of the operating pressure and functional diameter.

### IMPORTANT NOTE

The above data are maximum values and cannot be used at the same time, e.g. the maximum operating speed depends on material type, pressure, temperature and gap value. Temperature range also depends on media.

\* In the case of unpressurized piston applications in temperatures below 0 °C please contact your local Customer Solution Center for more information!

### INSTALLATION INSTRUCTIONS

AQ-Seal® 5 is installed according to information on page 247 to 249 and 251.

### RECOMMENDED MATERIALS

The following material combinations have proven effective for hydraulic applications:

#### Turcon® AQ-Seal® 5 in Turcon® M12

All round material for light to heavy hydraulic applications with linear movements in mineral oils, flame retardant hydraulic fluids, bio-oils and phosphate ester:

O-Ring and Quad-Ring®:	NBR 70 Shore A	N
	FKM 70 Shore A	V

Set code: M12N or M12V

#### Turcon® AQ-Seal® 5 in Turcon® T46

For medium to heavy applications with linear movements in mineral oils and other media with good lubrication:

O-Ring and Quad-Ring®:	NBR 70 Shore A	N
	FKM 70 Shore A	V

Set code: T46N or T46V

For specific applications, all Turcon® materials are available.

Other material combinations are listed in Table 99.

**Table 99: Turcon® Materials for AQ-Seal® 5**

Material, Applications, Properties	Code	O-Ring Material Shore A***	Code	O-Ring and Quad-Ring® Operating Temp.* °C	Mating Surface Material	MPa max Dynamic
<b>Turcon® M12</b> First material choice for seals in linear motion Overall improved properties For new constructions and updating For all commonly applied hydraulic fluids including fluids with low lubrication performance Lowest friction and best sliding properties Lowest wear on seals Improved absorption of abrasive contaminants Low wear or abrasion of counter surface BAM tested Mineral fiber and Additives filled Color: Dark gray	M12	NBR 70	N	-30 to +100	Steel	50
		NBR 70 Low temp.	T	-45 to +80	Steel hardened Cast iron	
		FKM 70	V	-10 to +200	Stainless steel Titanium	
<b>Turcon® T08</b> For lubricating fluids and linear motion Very high compressive strength and extrusion resistance Hard counter surfaces is recommended Bronze filled Color: Light to dark brown, which may have variations in shading	T08	NBR 70	N	-30 to +100	Steel hardened	60
		NBR 70 Low temp.	T	-45 to +80	Cast iron	
		FKM 70	V	-10 to +200		
<b>Turcon® T10</b> For hydraulic and pneumatic For linear motion in lubricating and non-lubricating fluids High extrusion resistance Good chemical resistance Not for electrically conducting fluids BAM tested Carbon, graphite filled Color: Black	T10	NBR 70	N	-30 to +100	Steel	40
		NBR 70 Low temp.	T	-45 to +80	Stainless steel	
		FKM 70	V	-10 to +200		
		EPDM 70	E**	-45 to +145		
<b>Turcon® T29</b> For lubricating and non-lubricating fluids Good extrusion resistance Surface texture is not suitable for gas sealing Not for electrically conducting fluids Carbon fiber filled Color: Gray	T29	NBR 70	N	-30 to +100	Steel	30
		NBR 70 Low temp.	T	-45 to +80	Cast iron Stainless steel	
		FKM 70	V	-10 to +200		
		EPDM 70	E**	-45 to +145		

Table continues on next page



Material, Applications, Properties	Code	O-Ring Material Shore A***	Code	O-Ring and Quad-Ring® Operating Temp.* °C	Mating Surface Material	MPa max Dynamic
<b>Turcon® T40</b> For lubricating and non-lubricating fluids High frequency and short strokes Water hydraulics Surface texture is not suitable for gas sealing Carbon fiber filled Color: Gray	T40	NBR 70	N	-30 to +100	Steel Cast iron Stainless steel Aluminum	25
		NBR 70 Low temp.	T	-45 to +80		
		FKM 70	V	-10 to +200		
		EPDM 70	E**	-45 to +145		
<b>Turcon® T46</b> For lubricated hydraulics in linear motion High compressive strength High extrusion resistance Very good sliding and wear properties BAM tested Bronze filled Color: Light to dark brown, which may have variations in shading	T46	NBR 70	N	-30 to +100	Steel hardened Cast iron	50
		NBR 70 Low temp.	T	-45 to +80		
		FKM 70	V	-10 to +200		
<b>Zurcon® Z80</b> For lubricating and non-lubricating fluids Water based fluids, air and gases Dry air pneumatics High abrasion and extrusion resistance For service in abrasive conditions and media with particles Good chemical resistance Limited temperature capability (-60 to +80 °C) UHMWPE (Ultra High Molecular Weight Polyethylene) Color: White to off-white	Z80	NBR 70	N	-30 to (+100)	Steel Steel hardened Stainless steel Aluminum Ceramic coating	35
		NBR 70 Low temp.	T	-45 to +80		
		EDPM 70	E**	-10 to (+145)		

\* The O-Ring and Quad-Ring® Operation Temperature is only valid in mineral hydraulic oil (except EPDM).

\*\* Material not suitable for mineral oils.

\*\*\* Quad-Ring® material NBR 70 code: N7004

FKM 70 code: V7002

BAM: Tested by "Bundesanstalt Materialprüfung, Germany".

Highlighted materials are recommended.



## ■ Installation Recommendation

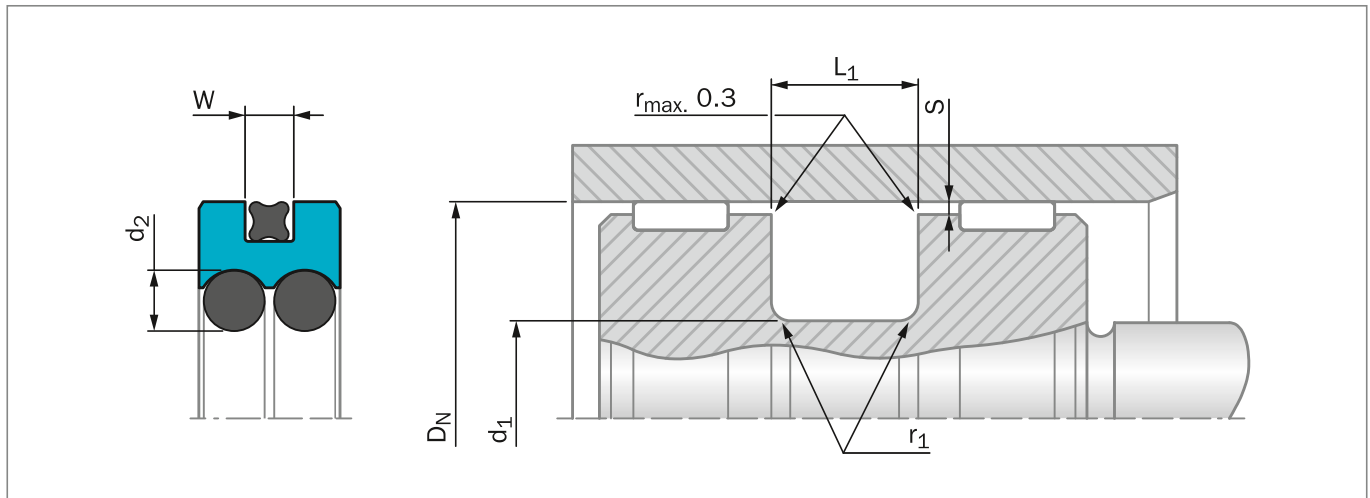

Figure 118: Installation Drawing

**Table 100: Installation Dimensions**

Series No.	Bore Diameter $D_N$ H9		Groove Diameter $d_1$ h9	Groove Width $L_1 +0.2$	Radius $r_1$ max	Radial Clearance $S_{max}^*$			O-Ring Cross Section $d_2$	Quad-Ring® Cross Section $W$
	Standard Application	Available Range				10 MPa	20 MPa	30 MPa		
PQ010	40 - 79.9	25 - 250	$D_N - 10.0$	6.3	0.6	0.30	0.20	0.15	2.62	1.78
PQ020	80 - 132.9	50 - 275	$D_N - 13.0$	8.3	1.0	0.40	0.30	0.15	3.53	2.62
PQ030	133 - 462.9	100 - 480	$D_N - 18.0$	12.3	1.3	0.40	0.30	0.20	5.33	3.53
PQ040	463 - 700.0	425 - 700	$D_N - 31.0$	16.3	1.8	0.50	0.40	0.30	7.00	5.33

\* At pressures > 30 MPa use diameter tolerance H8/f8 (bore/piston) in the area of the seal use Turcon® AQ-Seal® 5 CR or consult your local Customer Solution Center for alternative material or profiles.

Slydring® / Wear Rings are not applicable at very small radial clearances please consult the Slydring® section in this catalog.

### ORDERING EXAMPLE

Turcon® AQ-Seal® 5 complete with Quad-Ring® and O-Rings, standard application:

**Series:** PQ020 from Table 100

**Bore Diameter:**  $D_N = 80.0$  mm

**TSS Part No.:** PQ0200800 from Table 101

Select the material from Table 99. The corresponding code numbers are appended to the TSS Part No. Together they form the TSS Article Number. The TSS Article Number for all intermediate sizes can be determined by following the example:

**TSS Article No.** **PQ02 0 0800 - M12 N**

TSS Series No. ——— PQ02

Type (Standard) ——— 0

Bore Diameter x 10 ——— 0800

Quality Index (Standard) ——— M12

Material Code (Seal Ring) ——— N

Material Code (O-Ring)/(Quad-Ring® Seal) ———



**Table 101: Installation Dimensions / TSS Part No.**

Bore	Groove Diameter	Groove Width	Part No.	O-Ring Size	Quad-Ring® Size
D <sub>N</sub> H9	d <sub>1</sub> h9	L <sub>1</sub> +0.2			
<b>40.0</b>	<b>30.0</b>	<b>6.3</b>	<b>PQ0100400</b>	<b>29.82 x 2.62</b>	<b>34.65 x 1.78</b>
42.0	32.0	6.3	PQ0100420	31.42 x 2.62	37.82 x 1.78
45.0	35.0	6.3	PQ0100450	34.59 x 2.62	37.82 x 1.78
48.0	38.0	6.3	PQ0100480	37.77 x 2.62	41.00 x 1.78
<b>50.0</b>	<b>40.0</b>	<b>6.3</b>	<b>PQ0100500</b>	<b>39.34 x 2.62</b>	<b>44.17 x 1.78</b>
52.0	42.0	6.3	PQ0100520	40.94 x 2.62	47.35 x 1.78
55.0	45.0	6.3	PQ0100550	44.12 x 2.62	50.52 x 1.78
60.0	50.0	6.3	PQ0100600	48.90 x 2.62	53.70 x 1.78
<b>63.0</b>	<b>53.0</b>	<b>6.3</b>	<b>PQ0100630</b>	<b>52.07 x 2.62</b>	<b>56.87 x 1.78</b>
65.0	55.0	6.3	PQ0100650	53.64 x 2.62	60.05 x 1.78
70.0	60.0	6.3	PQ0100700	58.42 x 2.62	63.22 x 1.78
75.0	65.0	6.3	PQ0100750	63.17 x 2.62	69.57 x 1.78
<b>80.0</b>	<b>67.0</b>	<b>8.3</b>	<b>PQ0200800</b>	<b>66.27 x 3.53</b>	<b>71.12 x 2.62</b>
85.0	72.0	8.3	PQ0200850	69.44 x 3.53	75.87 x 2.62
90.0	77.0	8.3	PQ0200900	75.79 x 3.53	82.22 x 2.62
95.0	82.0	8.3	PQ0200950	78.97 x 3.53	82.22 x 2.62
<b>100.0</b>	<b>87.0</b>	<b>8.3</b>	<b>PQ0201000</b>	<b>85.32 x 3.53</b>	<b>88.57 x 2.62</b>
105.0	92.0	8.3	PQ0201050	91.67 x 3.53	94.92 x 2.62
110.0	97.0	8.3	PQ0201100	94.84 x 3.53	101.27 x 2.62
115.0	102.0	8.3	PQ0201150	101.19 x 3.53	107.62 x 2.62
120.0	107.0	8.3	PQ0201200	104.37 x 3.53	107.62 x 2.62
<b>125.0</b>	<b>112.0</b>	<b>8.3</b>	<b>PQ0201250</b>	<b>110.72 x 3.53</b>	<b>113.97 x 2.62</b>
130.0	117.0	8.3	PQ0201300	113.89 x 3.53	120.32 x 2.62
135.0	117.0	12.3	PQ0301350	113.67 x 5.33	123.42 x 3.53
140.0	122.0	12.3	PQ0301400	120.02 x 5.33	126.59 x 3.53
150.0	132.0	12.3	PQ0301500	129.54 x 5.33	136.12 x 3.53
<b>160.0</b>	<b>142.0</b>	<b>12.3</b>	<b>PQ0301600</b>	<b>139.07 x 5.33</b>	<b>145.64 x 3.53</b>
170.0	152.0	12.3	PQ0301700	148.49 x 5.33	158.34 x 3.53
180.0	162.0	12.3	PQ0301800	158.12 x 5.33	164.69 x 3.53
190.0	172.0	12.3	PQ0301900	170.82 x 5.33	177.39 x 3.53
<b>200.0</b>	<b>182.0</b>	<b>12.3</b>	<b>PQ0302000</b>	<b>177.17 x 5.33</b>	<b>183.74 x 3.53</b>
210.0	192.0	12.3	PQ0302100	189.87 x 5.33	196.44 x 3.53
220.0	202.0	12.3	PQ0302200	196.22 x 5.33	202.79 x 3.53
230.0	212.0	12.3	PQ0302300	208.92 x 5.33	215.49 x 3.53
240.0	222.0	12.3	PQ0302400	221.62 x 5.33	221.84 x 3.53
<b>250.0</b>	<b>232.0</b>	<b>12.3</b>	<b>PQ0302500</b>	<b>227.97 x 5.33</b>	<b>234.54 x 3.53</b>
280.0	262.0	12.3	PQ0302800	253.37 x 5.33	266.29 x 3.53
300.0	282.0	12.3	PQ0303000	278.77 x 5.33	278.99 x 3.53
<b>320.0</b>	<b>302.0</b>	<b>12.3</b>	<b>PQ0303200</b>	<b>291.47 x 5.33</b>	<b>304.39 x 3.53</b>
350.0	332.0	12.3	PQ0303500	329.57 x 5.33	329.79 x 3.53





Bore	Groove Diameter	Groove Width	Part No.	O-Ring Size	Quad-Ring® Size
$D_N$ H9	$d_1$ h9	$L_1$ +0.2			
<b>400.0</b>	<b>382.0</b>	<b>12.3</b>	<b>PQ0304000</b>	<b>380.37 x 5.33</b>	<b>380.59 x 3.53</b>
420.0	402.0	12.3	PQ0304200	405.26 x 5.33	380.59 x 3.53
450.0	432.0	12.3	PQ0304500	430.66 x 5.33	430.66 x 3.53
480.0	449.0	16.3	PQ0404800	443.36 x 7.00	456.06 x 5.33
<b>500.0</b>	<b>469.0</b>	<b>16.3</b>	<b>PQ0405000</b>	<b>468.76 x 7.00</b>	<b>456.06 x 5.33</b>
600.0	569.0	16.3	PQ0406000	557.66 x 7.00	557.58 x 5.33
700.0	669.0	16.3	PQ0407000	658.88 x 7.00	658.88 x 5.33

Bore diameters in **bold** type comply with the recommendations of ISO 3320.

All intermediate sizes up to 700 mm diameter can be supplied. Sizes > 700 mm diameter with special elastomers on request, see Turcon® AQ-Seal® with Bean Seal page 431.