

# Radial Oil Seal







## ■ Radial Oil Seal

### ■ General Seal Description

#### GENERAL

Radial Oil Seals, also known as rotary shaft lip seals, are round sealing devices used to seal between two machine parts that rotate relative to each other. They are used to seal lubrication in and/or contamination out, or to separate dissimilar media.

#### SEAL DESIGN

Although there are many styles of Radial Oil Seal, they all generally consist of a flexible rubber lip bonded to a rigid metal case. Most also contain a third element - a garter spring - fitted into the rubber lip to provide additional sealing force, both

initially and over the life of the seal. The total radial force of the sealing lip is a function of the rubber pre-tension, coupled with the tensile spring force. The sealing lip may be lathe cut or ready molded, and may feature molded-in hydrodynamic aids to assist sealing in demanding applications. The metal case may be exposed or have rubber molded around it for ease of assembly or improved static sealing.

Trelleborg Sealing Solutions offers state-of-the-art Radial Oil Seal design standards based on many years of experience in a wide range of application fields.

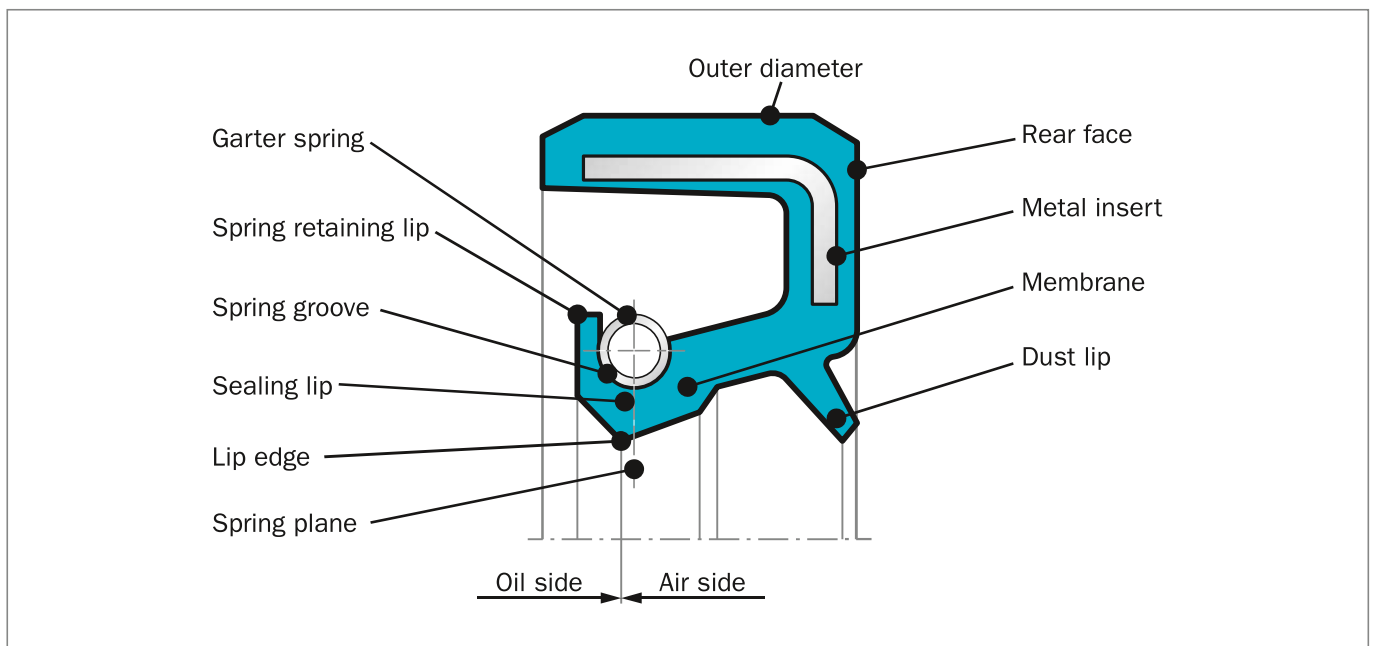

Figure 1: Designation for rotary shaft lip seals (extract from ISO 6194)



## METAL CASE

The metal case is normally made out of formed, cold-rolled steel sheet in accordance with DIN EN 10139. Another material, such as stainless steel or brass may be used, depending on application requirements. If the metal case is rubber-covered, the outside diameter may be either smooth or ribbed. In all cases, the seal outer diameter tolerance is in accordance with ISO 6194-1 and the bore tolerance is in accordance with ISO H8.

**Table 1: Outer Diameter Tolerances in Accordance with ISO 6194-1**

Nominal Outside Diameter $d_2$	Diametral Tolerance	
	Metal Cased	Rubber Covered
$D_2 \leq 50$	+0.20	+0.30
	+0.08	+0.15
$50 < D_2 \leq 80$	+0.23	+0.35
	+0.09	+0.20
$80 < D_2 \leq 120$	+0.25	+0.35
	+0.10	+0.20
$120 < D_2 \leq 180$	+0.28	+0.45
	+0.12	+0.25
$180 < D_2 \leq 300$	+0.35	+0.45
	+0.15	+0.25
$300 < D_2 \leq 530$	+0.45	+0.55
	+0.20	+0.30

Note: Ribbed O.D tolerances on request.

## GARTER SPRING

### Function

When rubber is exposed to heat, pressure or chemical attack, it will gradually lose its original properties. The rubber is then said to have aged, causing the original radial force exerted by the sealing element to diminish. The function of the garter spring is to maintain the radial force during this period.

Experiments have shown that the radial force must vary with the size and type of seal. They have also clearly indicated the significance of maintaining the radial force within narrow limits during the service life of the seal. Extensive investigations in the laboratory have formed the basis for defining the radial force.

The garter spring is closely wound and carries an initial tension. The total force exerted by the spring consists of the force required to overcome the initial tension and the force due to the spring rate. The use of a garter spring with initial tension ensures that, as the sealing element wears, the total radial force from the initial tension will not change.

### Material

Spring steel is normally used. If resistance to corrosion is required, stainless steel can be substituted. Garter springs of bronze or similar materials are not recommended, since they tend to fatigue after long service life, or as a result of exposure to high temperatures. In special cases, the garter spring can be protected against damage by means of a thin rubber cover.



## ■ Design Instructions: Shaft

### SURFACE FINISH, HARDNESS AND MACHINING METHODS

The shaft design is vital for sealing performance and ensures maximum service life for the seal (see Figure 4). As a basic principle, the hardness of the shaft should be higher as peripheral speeds increase. DIN 3760 specifies that the shaft must be hardened to at least 45 HRC.

As the peripheral speeds increase, the hardness must be increased, and at 10 m/s a hardness of 60 HRC is required. The choice of a suitable hardness is dependent not only on the peripheral speed but also on such factors as lubrication and the presence of abrasive particles. Poor lubrication and difficult environmental conditions require a higher shaft hardness. DIN 3760 specifies a surface roughness of Ra 0.2 - Ra 0.8  $\mu\text{m}$ . Laboratory tests have however proved that the most suitable roughness is  $R_t = 2 \mu\text{m}$  ( $R_a = 0.3 \mu\text{m}$ ). Both rougher and smoother surfaces generate higher friction, resulting in increased temperature and wear. Trelleborg Sealing Solutions suggest a surface roughness of Ra 0.2 - 0.5  $\mu\text{m}$ .

Measurements of friction and temperature have also shown that grinding of the shaft is the best method of machining. However, spiral grinding marks may cause a pumping effect. Therefore, plunge grinding should be used, during which even ratios between grinding wheel speed and work-piece should be avoided. Polishing of the shaft surface with a polishing cloth produces a surface which causes higher friction and increases heat generated when compared with plunge grinding. In certain cases, it may be impossible to provide the necessary hardness, surface finish and corrosion resistance required for the shaft. This problem can be solved by fitting a separate sleeve onto the shaft. If wear should occur, only the sleeve needs to be replaced (see page 145 Shaft repair kit).

### SHAFT RUN OUT

Shaft run out should as far as possible be avoided or kept to a minimum. At higher speeds, there is a risk that the inertia of the sealing lip prevents it from following the shaft movement. The seal must be located next to the bearing and the bearing play should be maintained at the minimum value possible (see Figure 2).

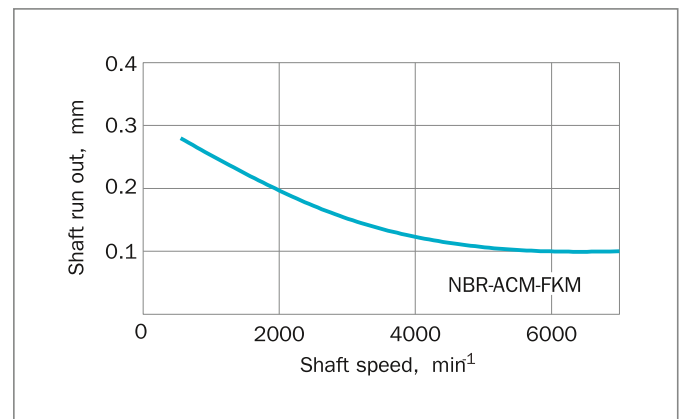

Figure 2: Shaft run out

### ECCENTRICITY

Eccentricity between shaft and housing bore centers should be avoided in order to eliminate unilateral load of the lip (see Figure 3).

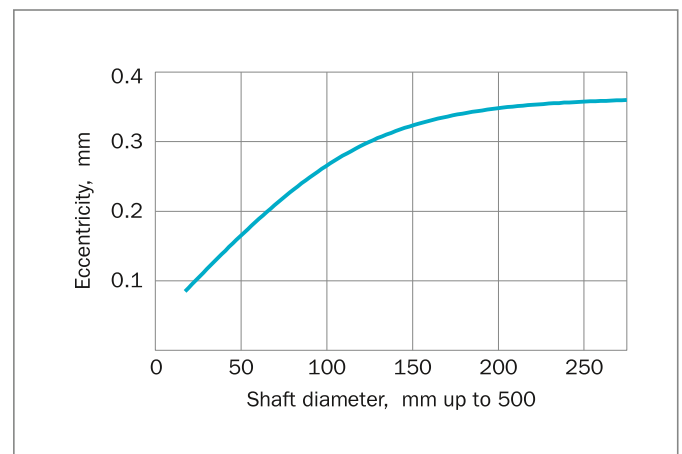

Figure 3: Eccentricity





## ■ Design Instructions: Housing Bore

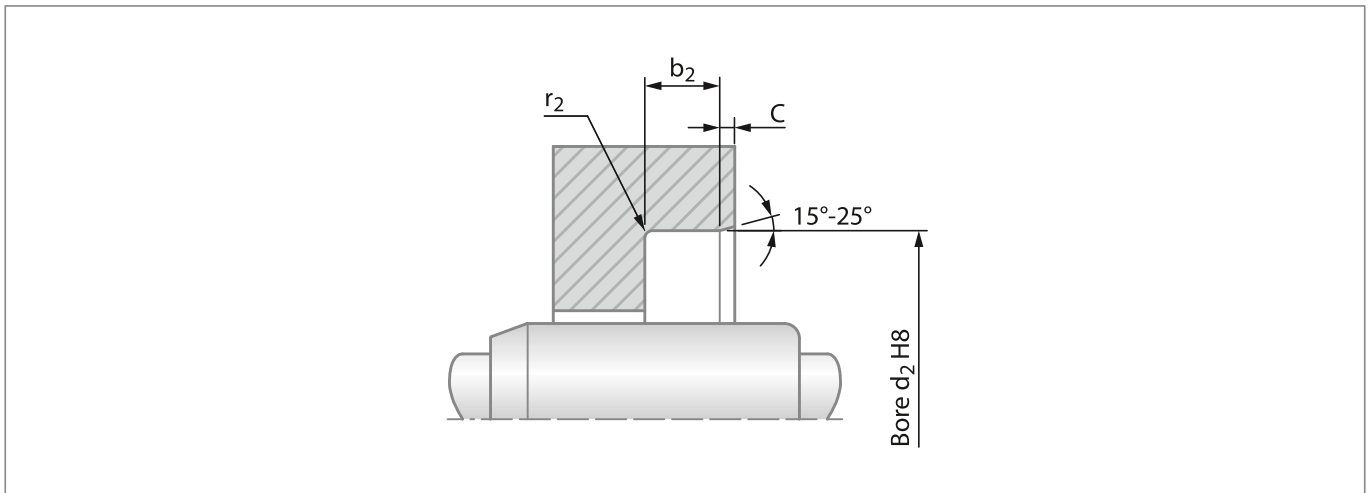

Figure 6: Installation depth and lead-in chamfer

### HOUSING BORE

For metric sizes, the tolerances are in accordance with ISO 6194-1, which provides a suitable press fit for the bore tolerance in ISO H8. The inch sizes are in accordance with ARPM OS-4 cases where the housing bore has a different tolerance, the seal can be made to a suitable size. For bearing housings made of soft materials, e.g. light metals, and for bearing housings with thin walls, a special fit between the seal and the housing may be necessary. The tolerances for the seal and housing should then be determined by practical assembly trials. If a component such as a bearing is assembled through the housing bore for the seal, the bore may be damaged. In order to avoid damaging the bore, a seal with a larger outside diameter than that of the bearing should be selected.

Table 3: Housing Dimensions

Ring Width b	C mm	b <sub>2</sub> (b + 0.3) mm	r <sub>2</sub> max.
7	0.7 to 1.0	8.2	0.5
8	0.7 to 1.0	9.2	0.5
10	0.7 to 1.0	11.2	0.5
12	1.0 to 1.3	13.5	0.75
15	1.0 to 1.3	16.5	0.75
20	1.0 to 1.3	21.5	0.75

### SURFACE ROUGHNESS OF THE HOUSING

Values for the surface roughness in the gland are specified in ISO 6194/1.

General values:            Ra = 1.6 - 3.2 µm  
                                       Rz = 6.3 - 12.5 µm

For metal-to-metal sealing or gas sealing, a good score-free and spiral-free surface finish is necessary. If the rotary shaft lip seal is bonded into the housing, ensure that no adhesive comes into contact with the sealing lip or the shaft.



## SEALING ELEMENT

### Compound

The material selected must take into account environmental conditions and function requirements.

Some of the requirements associated with environmental considerations are:

- Good chemical resistance
- Good resistance to heat and low temperature
- Good resistance to ozone and weathering

The functional demands include:

- High resistance to wear
- Low friction
- Low compression set
- Good elasticity

In addition, cost considerations render ease of processing a desirable feature. For the optimum material recommendation for your application, contact your local Trelleborg Sealing Solutions marketing company.

### Type and Designations of Materials

Nitrile rubber	(NBR)
Acrylic rubber	(ACM)
Fluorinated rubber	(FKM)
Hydrogenated Nitrile rubber	(HNBR)

In order to satisfy the wide range of demands made on seals, Trelleborg Sealing Solutions has developed special unique compounds of each type of rubber. Other material compounds are also available to meet extreme requirements.

**Table 4: Material Recommendations**

Materials for Sealing Common Media		Material Designation			
		Acrylonitrile Butadiene Rubber NBR	Fluorocarbon Rubber FKM	Polyacrylate Rubber ACM	Hydrogenated Acrylonitrile Butadiene Rubber HNBR
		Material Abbreviation			
		N	V	A	H
		Max. Permissible Constant Temperature (°C)			
Mineral fluids	Engine oils	100	170	125	130
	Transmission oils	80	150	125	110
	Hypoid transmission oils	80	150	125	110
	ATF oils	100	170	125	130
	Hydraulic fluids (DIN 51524)	90	150	120	130
	Greases	90	-	-	100
Flame retardant hydraulic fluids (VDMA 24317) (VDMA 24320)	Oil-water emulsion	70	-	-	70
	Water-oil emulsion	70	-	-	70
	Aqueous solutions	70	-	-	70
	Water-free fluids	-	150	-	-
Other media	Fuel oils	90	-	-	100
	Water	90	100	-	100
	Lyes	90	100	-	100
	Air	100	200	150	130

Due to the different configurations of the media, the above-mentioned temperature ranges are for guidance only. Depending on the media, significant deviations may occur.





## ■ Description of Rubber Materials

### NITRILE RUBBER (NBR)

#### Advantages:

- Good oil resistance
- Good heat resistance up to +100 °C in oil
- High tensile strength (special compounds over 20 MPa)
- High elongation at break
- Low swelling in water

#### Limitations:

- Poor weather and ozone resistance
- Poor resistance against polar fluids (ester, ether, ketones and aniline)
- Poor resistance against chlorinated hydrocarbons (carbon tetrachloride, trichlorethylene)
- Poor resistance against aromatic fluids (e.g. benzene, toluene)

Fluids, mineral oils and, above all, high-alloyed mineral oils (hypoid oils) containing larger quantities of aromatic hydrocarbons have a high swelling effect on NBR compounds. The swelling behavior can be improved by increasing the acrylonitrile content.

However an inferior cold flexibility and resistance to compression set must be accepted. The additives in high-alloyed oils can in certain cases cause an additional interaction between the elastomer and the additive, thus influencing the elasticity.

### HYDROGENATED NITRILE RUBBER (HNBR)

#### Advantages:

- Good oil resistance, also in hypoid oils
- Good heat resistance, up to +150 °C
- Good mechanical properties
- Good weather and ozone resistance

#### Limitations:

- Poor resistance against polar fluids (esters, ethers, ketones and aniline)
- Poor resistance against chlorinated hydrocarbons (carbon tetrachloride, trichlorethylene)
- Poor resistance against aromatic fluids (benzene, toluene)

### POLYACRYLIC RUBBER (ACM)

#### Advantages:

- Good resistance against oils and fuels (better than Nitrile rubber)
- Heat resistance about +50 °C better than for Nitrile rubber, +150 °C in oil and +125 °C in air
- Good weather and ozone resistance

#### Limitations:

- Not usable in contact with water and water solutions, even smaller quantities of water in oil
- Limited cold flexibility to about -20 °C, somewhat poorer than normal NBR
- Limited tensile strength and tear resistance, especially above +100 °C
- Poor wear resistance (considerably inferior compared to NBR)
- Poor resistance against polar and aromatic fluids and chlorinated hydrocarbons

### FLUORINATED RUBBER (FKM)

#### Advantages:

- The resistance against oils and fuels is better than for any other rubber type
- The only highly elastic rubber material, which is resistant to aromatic and chlorinated hydrocarbons
- Excellent heat resistance, up to +200 °C
- Excellent weather and ozone resistance
- Excellent acid resistance (only inorganic acids, not suitable for organic acids e.g. acetic acid)

#### Limitations:

- Limited cold flexibility, to approximately +20 °C to -25 °C
- Limited tensile and tear strength, especially above +100 °C
- High compression set in hot water
- Poor resistance to polar solvents



## FLUROSILICONE (FVMQ)

### Advantages:

- Very low temperature flexibility down to -60 °C
- Excellent heat resistance, up to +230 °C
- Good compatibility with most mineral oils

### Advantages:

- Expensive material
- Not suitable with polar fluids

## FDA-COMPOUNDS

Trelleborg Sealing Solutions has engineered a set of compounds suitable to be used in rotary sealing applications like gearboxes, mixers and other equipment requiring a separation between lubricants and food or any external chemicals.

The elastomeric lip is energized by a spring and can be designed like any Radial Oil Seal in order to effectively work under pressure, with shaft eccentricities and vibrations, and with axial play.

Available types of compounds are updated according to state-of-the-art regulations like the FDA. Most available Radial Oil Seals are molded from EPDM and FKM polymers, bonded to stainless steel metal inserts and energized with special INOX springs. The engineering of these items is usually made according to customer specifications.



## ■ Working Parameters

### TEMPERATURE RESISTANCE

Increasing temperature accelerates the aging of the rubber, the material becomes hard and brittle, the elongation decreases and the compression set increases. Axial cracks at the sealing edge are a typical indication that the seal has been exposed to excessively high temperature.

The aging of the rubber has appreciable significance on the useful life of the seal. The temperature limits for the principal materials are illustrated in Figure 7. They should only be regarded as approximate, since the materials are also affected by contact media. It can generally be said that a temperature increase of +10 °C (in air) will halve the theoretical useful life of the rubber.

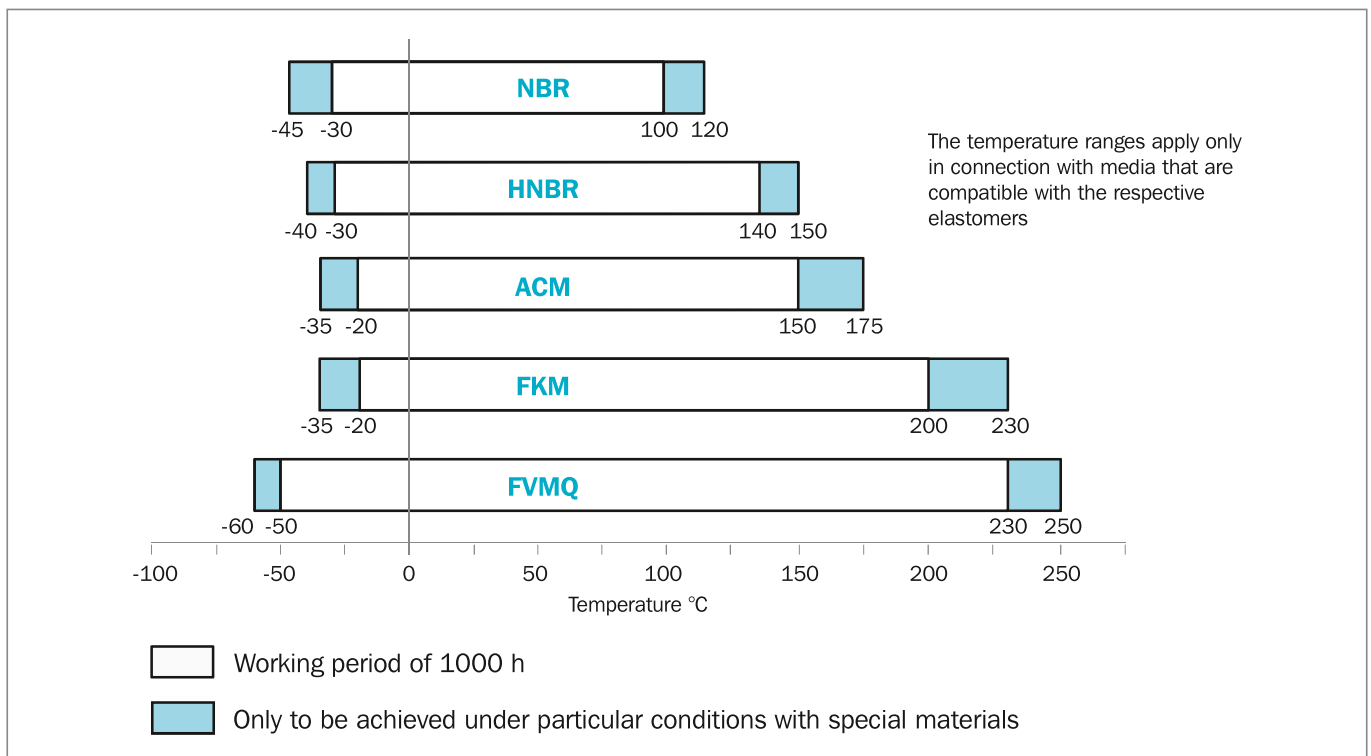

Figure 7: Temperature limits for some common types of rubber

### TEMPERATURE

Temperature is the most critical criteria to be considered when selecting a rotary seal.

The temperature limits indicated in the selection tables are maximum operating temperatures of the sealing material in fluids to which the sealing material is compatible (good chemical resistance and controlled swelling/shrinkage).

The above descriptions show that the temperature in the sealing area is influenced by various parameters especially:

- The lubricating capability of the fluid and its ability to dissipate the heat generated under the sealing lip.
- The circumferential velocity
- The pressure applied

The resulting temperature in the sealing area must be considered to select the appropriate material. The initial temperature of the fluid can increase by up to 50% depending on operating parameters. For all applications, please refer to the recommendations in the various chapters or contact your local Trelleborg Sealing Solutions marketing company.



## MEDIA

The media to be sealed heavily influences the choice of the seal and material type. Usually in rotary applications, liquid media are being contained. Pasty media generally restricts the use of rotary seals, especially with regards to circumferential velocity. Gaseous media require specially adapted seal designs.

### Liquid media:

Most applications relate to lubricating fluids, but there are also those with hydraulic fluids based on mineral oils in accordance with DIN 51524 or ISO 6743, or fire-resistant and environmentally friendly hydraulic fluids. More rarely, very aggressive media with low lubricating capabilities must be sealed. Sealing of other fluids such as water or FDA compliant fluids require in many cases a special sealing solution and will not be covered in detail in this catalog. For specific requirements, please contact your local Trelleborg Sealing Solutions marketing company. The media is the first criteria to be considered when selecting the sealing material type. It will also influence the seal family and the profile.

The evaluation of the compatibility of the seal material with the media to be sealed is based on the analysis of the values of tensile strength, elongation, volume change and hardness change resulting from an immersion test. Please contact your local Trelleborg Sealing Solutions marketing company to select the optimum material for your application.

### Mineral oils:

Mainly used in transmissions, elastomer materials have good compatibility with mineral oils within the recommended temperature range. Some mineral oils e.g. hypoid transmission oils contain special additives which produce more demanding operating conditions e.g. temperature range and/or high pressure. For these fields testing is recommended.

### Synthetic oils:

For improvement of the viscosity, high temperature and/or service life, new oils with specific additives have been launched as partial or full synthetic oils. Elastomer sealing materials give the same good compatibility to synthetic mineral oils as they do to mineral oils. However, compatibility needs to be checked.

### Grease:

Often used for roller and plain bearings, this media requires a specially adapted sealing solution. To reduce the risk of tilting and to allow the sealing lip to open under increasing pressure, the seal is installed in the reverse direction. Another important parameter to be considered is the maximum circumferential velocity. The maximum speed must be reduced to 50% of the permitted speed in oil, due to the poor heat exchange the grease can provide.

Above this limit, the change from grease to oil or installation of a seal with a PTFE-based lip (Turcon®) should be considered.

### Poor lubricating media:

For poor lubricating media, an initial lubrication of the seal is required to avoid dry running. In such applications, we recommend a Radial Oil Seal with dust lip. The area between the lips will be used as a lubricant reservoir. Two seals in tandem Radial Oil Seal/Radial Oil Seal or Radial Oil Seal/GAMMA Seal will provide the same result.

### Aggressive media:

Generally aggressive media (e.g. solvents) have poor lubricating properties and therefore we recommend Turcon® Varilip® or PDR seals. Turcon® and other PTFE materials solve the problem of chemical resistance and the metal cage can be produced out of various Stainless Steel materials to increase performance and product lifetime.



## ENVIRONMENTALLY-FRIENDLY HYDRAULIC FLUIDS (BIO OILS)

When machines or process equipment are hydraulically operated, escaping hydraulic oil can pollute surface waters and the ground. One way of minimizing the danger posed by unwanted leakage, is the use of biologically degradable, non-toxic oils. In many countries, there are already statutory regulations and catalogs of requirements for dealing with materials that endanger water. Hydraulic and transmission fluids that protect the environment are already specified in some cases. Figure 8 shows types of biodegradable fluids.

Environmentally-friendly fluids have applications in all systems that operate in mobile and agricultural machinery and in the water and forestry industries, for example. In stationary systems, they are employed in plants where water is at risk, such as locks, water turbines and for foodstuffs and pharmaceutical products.

An important criterion for biologically rapidly-degradable fluids is their compatibility with seals. In Table 5, the resistance of elastomeric materials are given to "bio-oils".

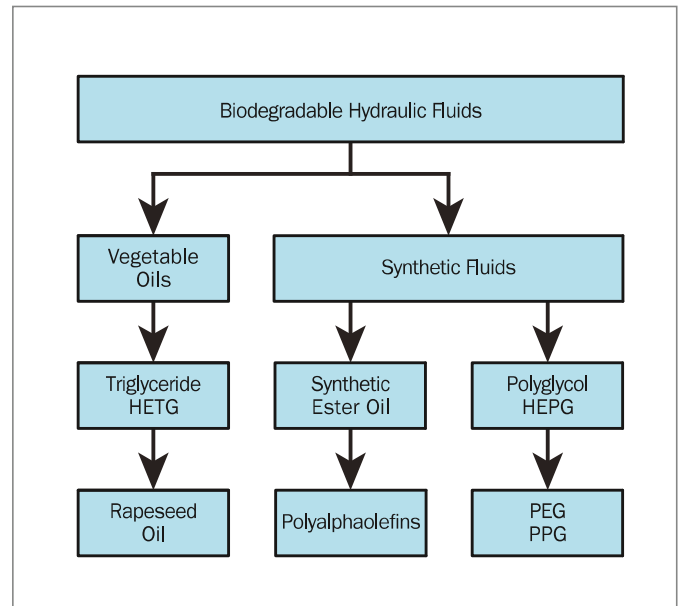

Figure 8: Biodegradable hydraulic fluids

**Table 5: Recommendations for the Use of Standard Elastomer Materials in Accordance with ISO VG 32 to 68 and VDMA Directive 24569**

Oil Temperature	< 60 °C	< 80 °C	< 100 °C	< 120 °C
Oil Type / ISO VG	32 - 68	32 - 68	32 - 68	32 - 68
HETG ( Rapeseed )	NBR HNBR FKM	NBR HNBR FKM	- - -	- - -
HEES	NBR* HNBR* FKM*	NBR* HNBR* FKM	- - FKM	- - FKM
HEPG ( PAG )	NBR* HNBR* FKM*	NBR HNBR FKM**	- HNBR FKM**	- HNBR FKM**
HEPR ( PAO )	not yet specified	not yet specified	not yet specified	not yet specified

\* For dynamic application, specific test required

\*\* Preferred peroxide cured FKM



### OVERPRESSURE

When the sealing element is exposed to pressure, it is forced against the shaft and the area of the lip in contact with the shaft increases. The friction, as well as the generated heat, increases. As a result, when the seal is under pressure, the specified values of peripheral speed cannot be maintained but must be reduced in relation to the magnitude of the pressure. At high peripheral speeds even overpressures of 0.01 to 0.02 MPa may cause difficulties. By fitting a separate Back-up Ring, the types (TRA, TRC, TRB) can be used for overpressure above 0.05 MPa. The separate Back-up Ring shape follows the rear profile of the sealing element but without mutual contact when no pressure differential exists (see Figure 9). However, the Back-up Ring requires accurate fitting.

Please ask your local Trelleborg Sealing Solutions marketing company for suitable Back-up Ring drawings. Seal type TRU is formed to support the sealing element (see Figure 9). The type TRP/6CC is designed with a short and sturdy sealing lip, which allows overpressures without using a separate Back-up Ring. When a Back-up Ring is installed or when the types TRU, TRP/6CC are used, overpressures of 0.4 to 0.5 MPa are permissible at moderate peripheral speeds.

At very high pressures, seals with rubber-covered cases should be used to avoid leakage between the periphery of the seal and the housing bore. When the seal is under pressure there is a risk of axial movement in the housing bore (pop-out). This effect can be prevented by locating the seal against a shoulder, with a spacer ring or a circlip.

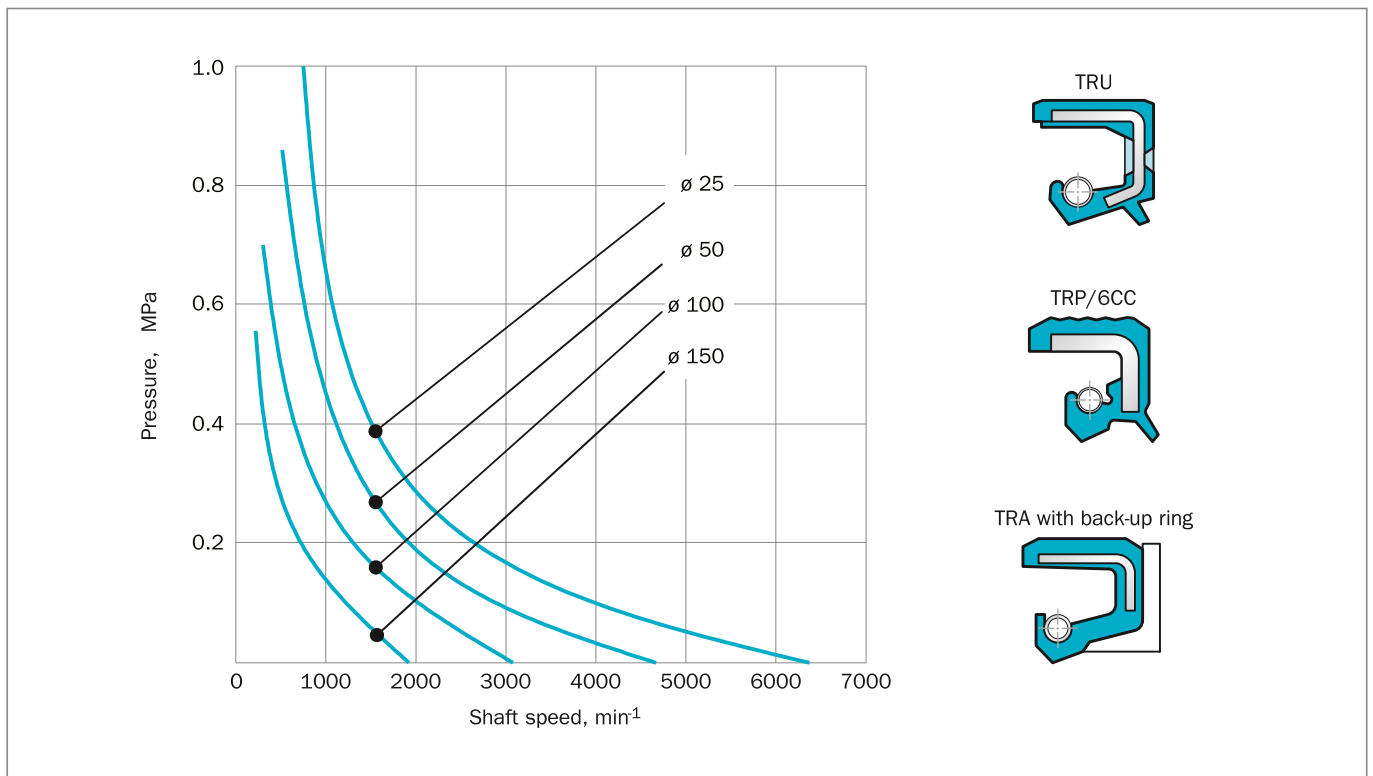

Figure 9: Permissible overpressure for supported lip seals and for pressure seals



## PERIPHERAL SPEED AND NUMBER OF REVOLUTIONS

Different designs of the sealing element affect the magnitude of the friction and thus result in varying temperature rises. Various designs of the sealing element allow different maximum peripheral speeds. Figure 10 shows the approximate maximum values for the permissible peripheral speed for sealing elements (without dust lip), i.e. seal type TRC, TRA, TRB, etc, made with materials NBR or FKM, with no differential pressure, and where adequate lubrication or cooling of the sealing edge by the sealed media exists. In addition, the maximum permissible operating temperatures shown in Table 4 must not be exceeded. The curve shows that higher peripheral speeds are permissible for larger shaft diameters more than for the smaller. This is due to the fact that the cross-sectional area increases in proportion to the square of the diameter, thus increasing the heat dissipation capacity.

TRB, etc, made with materials NBR or FKM, with no differential pressure, and where adequate lubrication or cooling of the sealing edge by the sealed media exists. In addition, the maximum permissible operating temperatures shown in Table 4 must not be exceeded. The curve shows that higher peripheral speeds are permissible for larger shaft diameters more than for the smaller. This is due to the fact that the cross-sectional area increases in proportion to the square of the diameter, thus increasing the heat dissipation capacity.

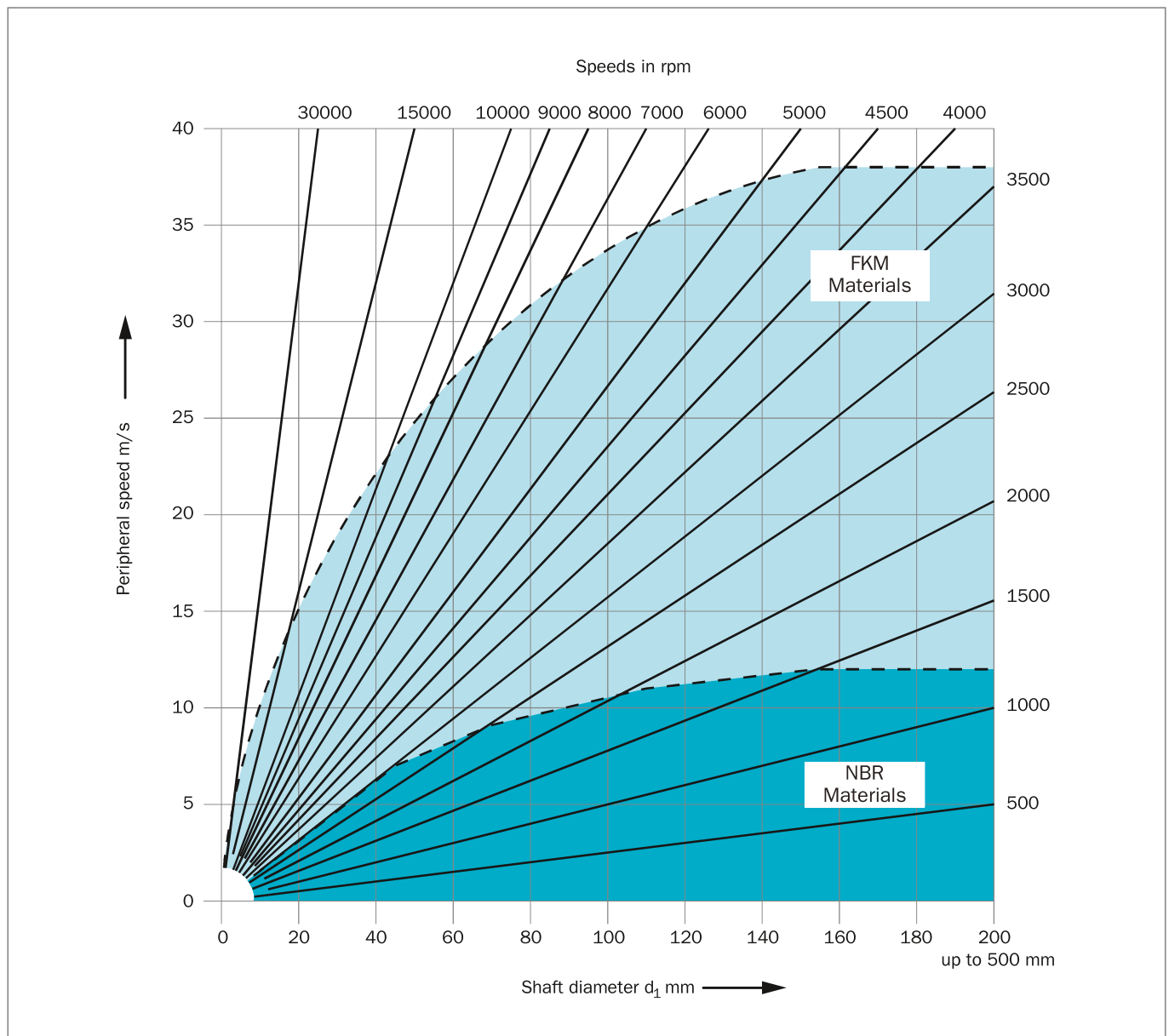

Figure 10: Permissible speeds in pressure-free state to DIN 3761



## FRICITIONAL LOSS

The frictional loss is often of significant magnitude, particularly when low powers are transmitted. The frictional loss is affected by the following parameters: seal design and material, spring force, speed, temperature, medium, shaft design, and lubrication. Figure 11 shows the frictional losses in watts caused by a seal without dust lip when fitted in accordance with our technical instructions. In certain cases, the frictional loss can be reduced by a special design of the sealing lip, reduction of the spring force or by employing a special grade of rubber. Trelleborg Sealing Solutions engineering teams will be pleased to provide advice on such matters. It should be noted that the frictional loss during the running in period is greater than shown in the figure. The normal running in period is a few hours.

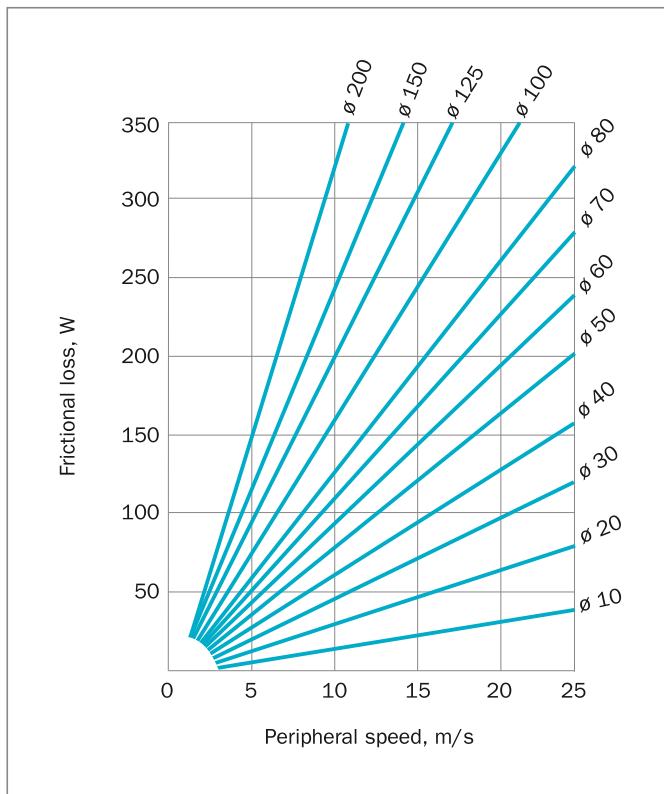

Figure 11: Frictional loss for TRA type seal of Nitrile rubber

## LEAKAGE CONTROL

When defining leakage control, one must differentiate between static sealing (sealing of two surfaces without motion relative to one another) and dynamic sealing (relative motion between the two surfaces).

With a moving seal surface, a fluid film separates the sliding surfaces from one another forming a dynamic seal gap. Unlike in static sealing, the leakage path is not fully closed off, so small quantities may escape. Seals in which a dynamic seal gap forms between the seal body and a rotating shaft cannot be tight in the physical sense.

Absolute tightness in the physical sense cannot be achieved with a seal gap alone when sealing moving parts.

For many technical applications, however, it is quite adequate if the "leakage" is reduced to such an extent that there are no negative consequences for the environment or the operation of the assembly. This is called technical tightness.

Technical tightness must be specified by the user or manufacturer of an assembly, i.e. in some circumstances maximum permitted leakage rates must be defined.

For example, leakage classes are defined for oil seals in DIN 3761 Part II (Motor vehicles).

The German standard DIN 3761 classifies the tightness of lip seals into leakage classes 1 to 3. A so called zero-leakage is also defined. Zero-leakage means a function related film of moisture at the sealing edge to a non-drip formation of medium over the back-face of the seal. It is better to accept this "minimum leakage" rather than risking the lip to be damaged due to insufficient lubrication. The permissible leakage in class 1 to 3 is max 1 g to 3 g per seal for a test time of 240 hours.





## ■ Installation Instructions

The following points must be observed when installing rotary shaft lip seals:

- Before installing, clean the shaft and bore of debris or contamination
- Lubricate the shaft and seal inner diameter with a light coating of grease or oil
- Any sharp-edged transitions on the shaft or bore must either be chamfered or rounded
- When pressing the seal into the bore, take care that it does not deform
- The pressing force must be applied as close as possible to the outer circumference of the seal
- After installation, the seal must be concentric with the bore and at right angles to the shaft
- The end face of the mounting bore is generally used as a depth locator; the seal can also be fixed with a shoulder or a spacer washer.

Figure 12 shows various force fit situations of the rotary shaft lip seal, with suitable installation tools or devices.

### IMPORTANT NOTE

The installation of Radial Oil Seals is covered in detail in the Trelleborg Sealing Solutions Installation Instructions app. Search for 'Trelleborg' in the App Store or Google Play to find and download it.

## DISMANTLING AND REPLACEMENT

Dismantling of the seal can be accomplished using a screwdriver or similar tool. Take care not to damage the shaft or bore. The seal will be damaged during dismantling and should not be reused.

After repair or maintenance of a machine, a new rotary shaft lip seal must always be installed, even if the old one seems to be still usable. The sealing edge of the new seal should not ride on the same contact area on the shaft as the old seal. This can be achieved by:

- Replacement of shaft sleeves
- Fitting the seal into the bore to a different depth
- Reworking of the shaft and assembling a wear sleeve (see page 145 Shaft repair kit)

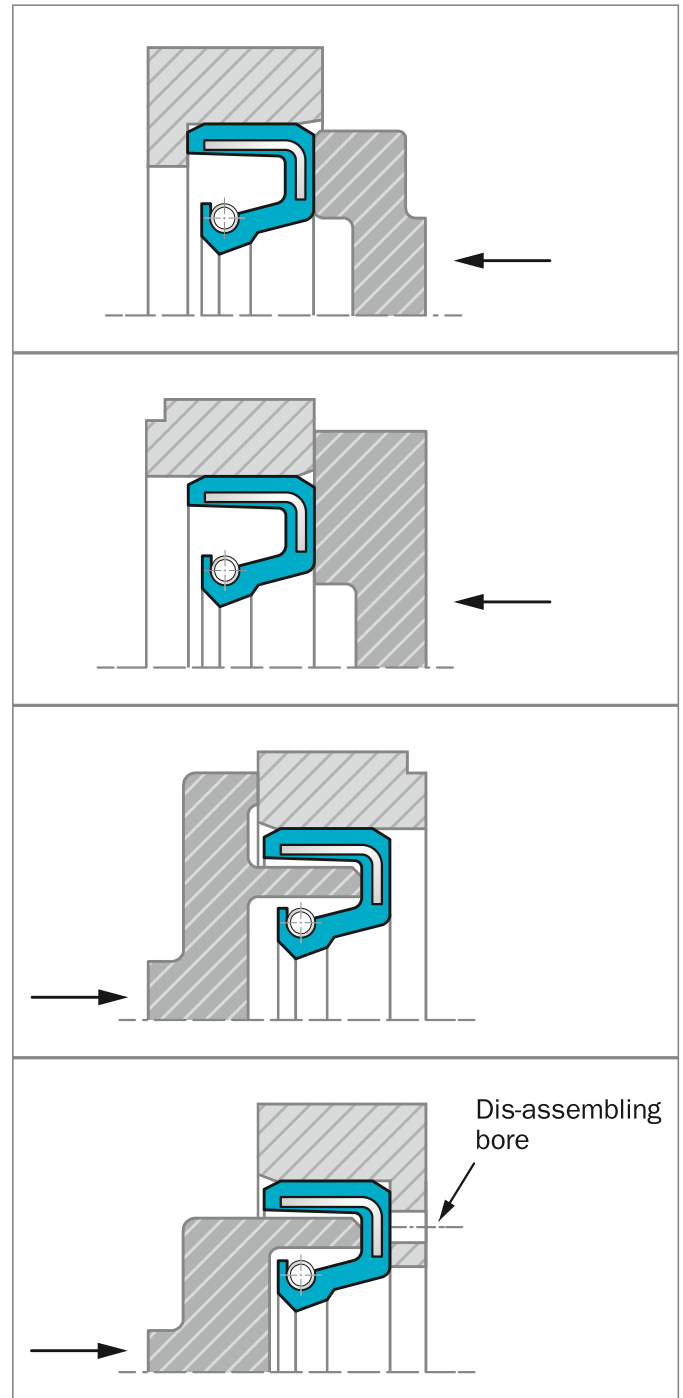

Figure 12: Installation aids for fitting rotary shaft lip seals



## ■ Standard Radial Oil Seal

Standard elastomeric rotary shaft seals are designed according to DIN 3760 (3761) and ISO 6194/1 recommendations. Types DIN A and DIN AS may have a **wavy or flat outer sheath**.

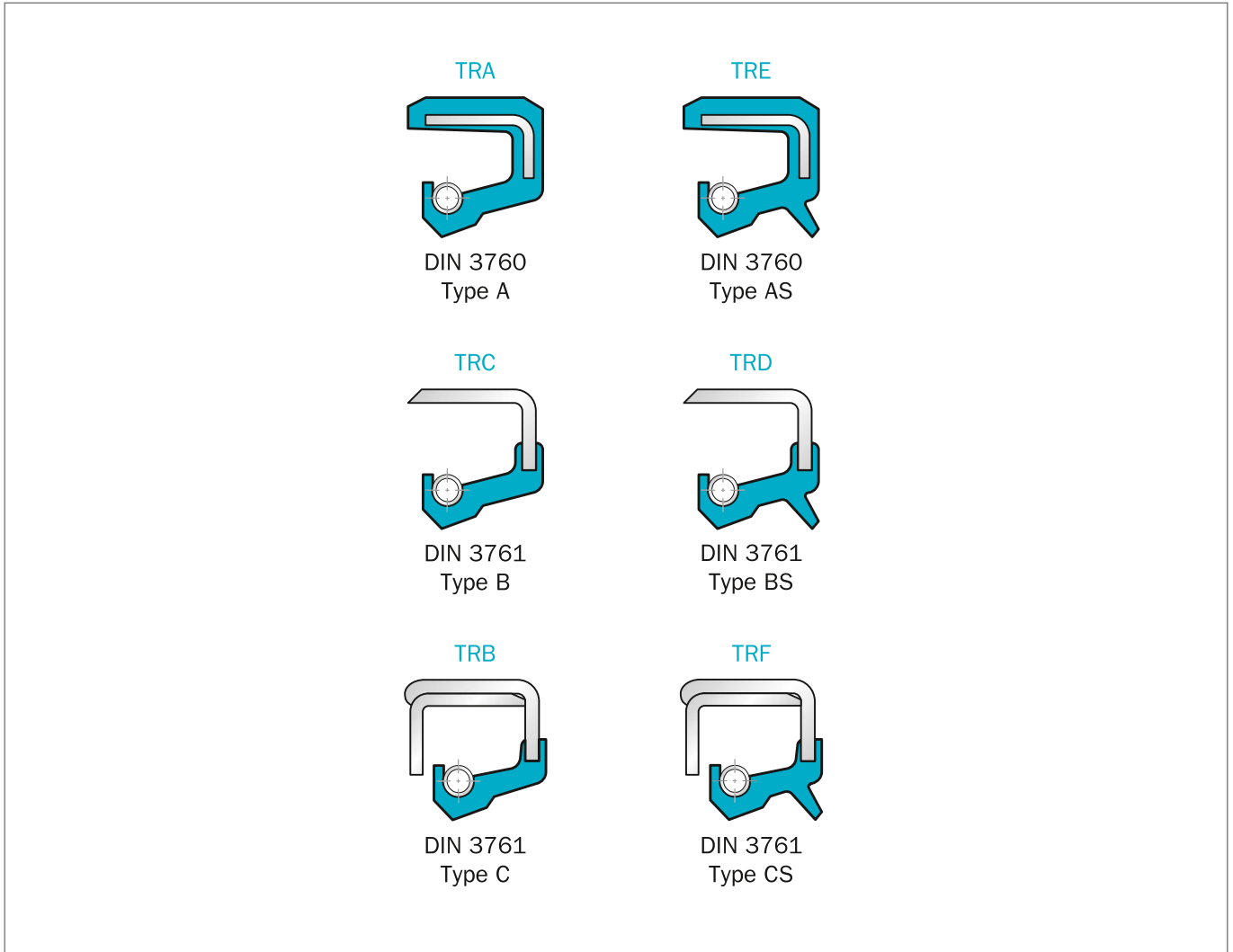

Figure 13: Standard types



## ■ Type TRA

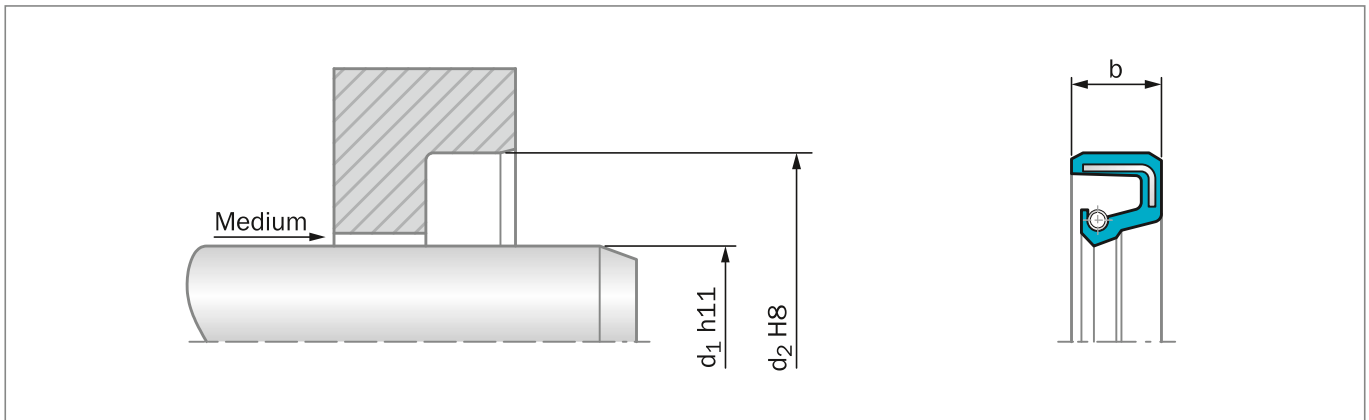

Figure 14: Installation Drawing

### GENERAL DESCRIPTION

Trelleborg Sealing Solutions type TRA are seals with completely rubber covered outer diameter. Two different O.D design are available: Flat rubber sheath and wavy.

This type is not recommended for use in heavily polluted environments.

### ADVANTAGES

- Good static sealing
- Compensation of different thermal expansion
- Reduced risk of fretting corrosion
- Higher bore surface roughness is allowed
- Installation in split-housings
- Modern lip design provides low radial forces

### APPLICATION EXAMPLES

- Transmission systems (e.g. gearboxes)
- Pumps
- Electrical motors
- Machine tools

### OPERATING CONDITIONS

<b>Pressure:</b>	Up to 0.05 MPa
<b>Temperature:</b>	-40 °C to +200 °C (depending on material)
<b>Speed:</b>	Up to 10 m/s (depending on material)
<b>Media:</b>	Mineral and synthetic lubricants (CLP, HLP, APGL etc.)

Trelleborg Sealing Solutions has carried out several thousand compatibility tests. Please ask your local Trelleborg Sealing Solutions marketing company for details.

### IMPORTANT NOTE

The above data are maximum values and cannot be used at the same time, e.g. the maximum operating speed depends on material type, pressure and temperature.



**Table 6: Materials**

TSS Compound Reference	Standard Compound	Temperature °C	Standard Metal Insert	Standard Spring
N7MMR	NBR (70 Shore A)	-30 °C - 100 °C	Carbon steel	Carbon steel
4N011/4NV11	NBR (75 Shore A)	-30 °C - 100 °C	Carbon steel	Carbon steel
VCBVR	FKM (70 Shore A)	-20 °C - 200 °C	Carbon steel	Stainless steel
4V012	FKM (75 Shore A)	-20 °C - 200 °C	Carbon steel	Stainless steel

Special grades and other materials (ACM, EACM, EPDM, HNBR, VMQ) on request.  
Metal insert and spring can be supplied in different materials on request.

**ORDERING EXAMPLE OIL SEAL TSS TYPE**

<b>TSS Type:</b>	A
<b>Code:</b>	TRA
<b>Dimensions:</b>	Shaft diameter 25 mm Housing diameter 40 mm Width 7 mm
<b>Material:</b>	NBR
<b>Material Code:</b>	N7MMR

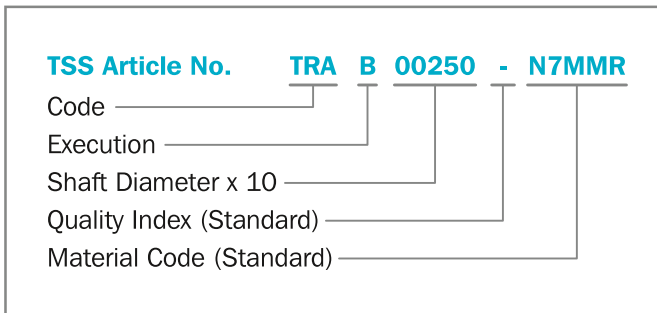

**Table 7: Preferred Series / Dimension, TSS Part Numbers**

Dimension			TSS Part No.	Material	
d <sub>1</sub>	d <sub>2</sub>	b		NBR	FKM
4	12	6	TRA100040	●	
5	16	7	TRA100050	●	
5	19	5	TRA400050	●	
5.5	22	7	TRA000055	●	
6	12	5.5	TRA400060	●	●
6	15	4	TRA000060	●	●
6	16	5	TRA100060	●	
6	16	7	TRAA00060	●	●
7	17	7	TRA200070	●	
7	22	7	TRAA00070	●	●
8	14	4	TRA700080	●	
8	16	5	TRA100080	●	
8	16	7	TRA200080	●	●
8	18	5	TRA300080	●	●
8	20	8	TRA800080	●	●
8	22	4	TRA500080	●	●
8	22	7	TRAA00080	●	●
9	22	7	TRAA00090	●	
9.5	25.4	8	TRA000095	●	
10	18	4	TRA200100	●	●
10	19	7	TRA400100	●	●
10	20	5	TRAH00100	●	
10	22	6	TRAE00100		●
10	22	7	TRAA00100	●	
10	24	7	TRAB00100	●	●
10	26	7	TRAC00100	●	●
11	19	7	TRA100110	●	
11	26	7	TRAB00110	●	
12	19	5	TRA000120	●	●
12	20	5	TRA200120	●	
12	22	4	TRAF00120	●	●
12	22	7	TRAA00120	●	●
12	24	7	TRAB00120	●	●
12	25	5	TRA600120	●	
12	26	7	TRA800120	●	●
12	28	7	TRAC00120	●	●
12	30	7	TRAD00120	●	●
12	32	7	TRAH00120	●	
12	37	10	TRAK00120	●	
13	25	5	TRA100130	●	
13	26	7	TRA200130	●	
13	30	8	TRA300130	●	
14	22	4	TRA000140	●	●
14	22	7	TRA400140	●	

● In one of the preferred materials  
○ In other commercial materials



Dimension			TSS Part No.	Material		Dimension			TSS Part No.	Material	
d <sub>1</sub>	d <sub>2</sub>	b		NBR	FKM	d <sub>1</sub>	d <sub>2</sub>	b		NBR	FKM
14	24	4	TRAE00140			20	30	7	TRAA00200	●	●
14	24	7	TRAA00140	●	●	20	30	8	TRAJ00200		●
14	25	5	TRA100140	●		20	32	7	TRAB00200	●	●
14	28	7	TRAB00140	●	●	20	35	6	TRA600200	●	
14	30	7	TRAC00140	●	●	20	35	7	TRAC00200	●	●
15	24	5	TRAF00150	●	●	20	37	7	TRAM00200	●	
15	24	7	TRA200150	●	●	20	37	8	TRA900200	●	
15	25	5	TRA300150	●		20	40	4	TRAL00200	●	
15	26	6	TRA400150	●		20	40	7	TRAD00200	●	●
15	28	7	TRA600150	●	●	20	42	7	TRAG00200	●	●
15	30	7	TRAB00150	●	●	20	47	7	TRAE00200	●	●
15	32	7	TRAC00150	●	●	20	52	7	TRA400200	●	
15	32	9	TRA800150	●		20	52	10	TRAK00200	●	
15	35	7	TRAD00150	●	●	21	30	6.5	TRA100210	●	
15	37	7	TRAE00150	●		22	32	7	TRAA00220	●	●
15	40	7	TRAN00150		●	22	35	5	TRA200220	●	
15	42	7	TRAG00150	●	●	22	35	7	TRAB00220	●	●
16	24	4	TRA500160	●	●	22	37	7	TRA300220	●	
16	24	5	TRA200160	●		22	40	7	TRAC00220	●	●
16	24	7	TRA300160	●	●	22	52	7	TRAN00220		●
16	26	7	TRA400160	●	●	22.5	53	10	TRA000225		●
16	28	7	TRAA00160	●	●	23	40	10	TRA100230	●	
16	30	7	TRAB00160	●	●	24	35	7	TRAA00240	●	●
16	32	7	TRAC00160	●		24	37	7	TRAB00240	●	
17	25	4	TRA100170	●	●	24	40	7	TRAC00240	●	●
17	26	6	TRA300170	●		24	47	7	TRAD00240	●	●
17	28	5	TRA400170	●	●	25	32	6	TRA000250	●	●
17	28	7	TRAA00170	●	●	25	33	6	TRA300250	●	●
17	30	7	TRAB00170	●	●	25	35	7	TRAA00250	●	●
17	32	7	TRAC00170	●	●	25	37	7	TRA700250	●	●
17	35	7	TRAD00170	●	●	25	38	7	TRA800250	●	●
17	37	7	TRAN00170	●		25	40	5	TRA900250	●	
17	40	7	TRAE00170	●	●	25	40	7	TRAB00250	●	●
17	47	7	TRAG00170	●	●	25	40	10	TRAG00250	●	●
18	24	4	TRA500180		●	25	42	7	TRAC00250	●	●
18	30	7	TRAA00180	●	●	25	43	10	TRAU00250		●
18	35	7	TRAC00180	●	●	25	45	7	TRAI00250	●	●
18	35	10	TRA300180	●		25	47	7	TRAD00250	●	●
19	27	6	TRA600190	●		25	47	8	TRAK00250	●	●
19	32	7	TRA200190	●		25	47	10	TRAL00250	●	●
19	35	7	TRA300190	●		25	52	7	TRAE00250	●	●
19.3	35	6	TRA000193	●		25	52	10	TRA000250	●	
20	28	6	TRA100200	●							
20	30	5	TRA200200	●	●						

- In one of the preferred materials
- In other commercial materials



Dimension			TSS Part No.	Material	
d <sub>1</sub>	d <sub>2</sub>	b		NBR	FKM
25	62	10	TRAR00250	●	
26	34	4	TRA100260	●	
26	37	7	TAA00260	●	
26	47	7	TRAC00260	●	●
27	37	7	TRA300270	●	
27	42	7	TRA000270	●	
27	50	8	TRA100270	●	
28	38	7	TRA000280	●	●
28	40	7	TAA00280	●	●
28	47	7	TRAB00280	●	●
28	47	10	TRA500280	●	●
28	52	7	TRAC00280	●	●
28	80	7	TRA100280	●	
30	40	7	TAA00300	●	●
30	42	5	TRAMGA004	●	
30	42	5.7	TRAV00300	●	
30	42	7	TRAB00300	●	●
30	45	7	TRA400300	●	●
30	45	8	TRA500300	●	
30	47	4	TRA800300	●	
30	47	7	TRAC00300	●	●
30	47	8	TRA900300	●	
30	47	10	TRAF00300	●	●
30	48	8	TRAG00300	●	
30	48	10	TRAMGA008	●	
30	52	7	TRAD00300	●	●
30	55	7	TRAN00300	●	●
30	55	10	TRA000300	●	●
30	62	7	TRAE00300	●	●
30	62	10	TRAR00300	●	●
30	72	8	TRAT00300	●	
30	72	10	TRAU00300	●	●
31	47	7	TRA000310	●	
32	45	7	TAA00320	●	●
32	47	7	TRAB00320	●	●
32	47	10	TRAM00320	●	
32	50	8	TRA400320	●	●
32	52	6	TRAJ00320	●	
32	52	7	TRAC00320	●	●
32	54	8	TRA900320		●
34	52	8	TRA300340	●	●
34	62	10	TRA600340	●	
35	45	7	TRA000350	●	●
35	47	7	TAA00350	●	●

Dimension			TSS Part No.	Material	
d <sub>1</sub>	d <sub>2</sub>	b		NBR	FKM
35	50	7	TRAB00350	●	●
35	52	7	TRAC00350	●	●
35	52	10	TRA500350	●	●
35	55	8	TRA600350	●	●
35	55	10	TRA700350	●	●
35	56	10	TRA900350	●	●
35	60	10	TRAH00350	●	
35	62	7	TRAD00350	●	●
35	62	10	TRAJ00350	●	●
35	68	10	TRAW00350		●
35	72	7	TRAM00350	●	
35	72	10	TRAN00350	●	●
35	72	12	TRA000350	●	
35	80	10	TRAQ00350	●	
35	80	13	TRAS00350	●	
36	47	7	TAA00360	●	●
36	50	7	TRAB00360	●	
36	52	7	TRAC00360		●
37	62	10	TRA200370	●	
38	50	7	TRA000380	●	●
38	52	7	TAA00380	●	●
38	54	6.5	TRA900380	●	●
38	55	7	TRAB00380	●	●
38	62	7	TRAC00380	●	●
38	65	8	TRAK00380	●	
40	50	8	TRA000400	●	●
40	52	7	TAA00400	●	●
40	55	7	TRAB00400	●	●
40	55	10	TRA500400	●	
40	58	10	TRAF00400		●
40	60	10	TRAH00400	●	●
40	62	7	TRAC00400	●	●
40	62	10	TRAI00400	●	●
40	65	10	TRAK00400	●	●
40	68	7	TRAM00400	●	●
40	68	10	TRAN00400		●
40	72	7	TRAD00400	●	●
40	72	10	TRAQ00400	●	●
40	80	7	TRAS00400		●
40	80	10	TRAT00400	●	●
40	85	10	TRAU00400	●	
40	90	8	TRAV00400	●	

- In one of the preferred materials
- In other commercial materials



Dimension			TSS Part No.	Material		Dimension			TSS Part No.	Material	
d <sub>1</sub>	d <sub>2</sub>	b		NBR	FKM	d <sub>1</sub>	d <sub>2</sub>	b		NBR	FKM
40	90	12	TRAW00400	●		50	80	8	TRAD00500	●	
42	55	7	TRA000420	●	●	50	80	10	TRAH00500	●	
42	55	8	TAA00420	●	●	50	90	10	TRAK00500	●	
42	56	7	TRA100420	●	●	52	68	8	TAA00520	●	●
42	60	10	TRA200420	●		52	72	8	TRAB00520	●	●
42	62	7	TRA300420	●	●	52	75	12	TRA300520		●
42	62	8	TRAB00420	●	●	52	85	10	TRA700520	●	
42	62	10	TRA400420	●		54	80	10	TRA400540	●	
42	72	7	TRA700420	●		55	68	8	TRA000550	●	●
42	72	8	TRAC00420	●		55	70	8	TAA00550	●	●
42	72	10	TRA800420	●		55	70	10	TRA100550	●	
44	62	10	TRA100440	●		55	72	8	TRAB00550	●	●
45	55	7	TRA200450	●		55	72	10	TRA200550	●	
45	60	7	TRA400450	●	●	55	75	10	TRA400550	●	●
45	60	8	TAA00450	●	●	55	80	7	TRAL00550	●	●
45	62	7	TRA600450	●	●	55	80	8	TRAC00550	●	●
45	62	8	TRAB00450	●	●	55	80	10	TRA600550	●	●
45	62	10	TRA800450	●	●	55	85	8	TRAD00550	●	
45	65	8	TRAC00450	●	●	55	85	10	TRA900550	●	●
45	65	10	TRAF00450	●	●	55	90	8	TRAP00550	●	
45	72	8	TRAD00450	●	●	55	90	10	TRAG00550	●	
45	72	10	TRAK00450	●	●	55	100	12	TRAK00550	●	
45	72	12	TRAW00450		●	56	72	8	TRAB00560	●	
45	75	8	TRAM00450	●		58	72	8	TAA00580	●	
45	75	10	TRAN00450	●	●	58	80	8	TRAB00580	●	●
45	80	8	TAA00450	●		58	80	10	TRA200580	●	
45	80	10	TRAP00450	●		58.5	100	12	TRA000585	●	
45	85	10	TRAR00450	●		60	70	7	TRA000600	●	
47	62	6	TRA000470	●		60	72	8	TRA100600	●	●
48	62	8	TAA00480	●	●	60	75	8	TAA00600	●	●
48	72	8	TRAB00480	●	●	60	78	10	TRA300600		●
48	80	10	TRA600480	●		60	80	7	TRA400600		●
50	62	7	TRA000500	●	●	60	80	8	TRAB00600	●	●
50	65	7	TRA200500		●	60	80	10	TRA500600	●	●
50	65	8	TAA00500	●	●	60	85	8	TRAC00600	●	●
50	65	10	TRA200500	●	●	60	90	8	TRAD00600	●	●
50	68	8	TRAB00500	●	●	60	90	10	TRAF00600	●	●
50	68	10	TRA300500	●	●	60	95	10	TRAH00600	●	●
50	70	8	TRA500500	●	●	60	100	10	TRAI00600		●
50	70	10	TRA600500	●	●	60	110	10	TRA200600	●	
50	72	6	TRA800500	●		60	110	12	TRAN00600	●	
50	72	7	TRAE00500	●		60	110	13	TRAJ00600	●	●
50	72	8	TRAC00500	●	●						
50	75	10	TRAG00500	●							

- In one of the preferred materials
- In other commercial materials



Dimension			TSS Part No.	Material	
d <sub>1</sub>	d <sub>2</sub>	b		NBR	FKM
62	75	10	TRA000620	●	
62	80	9	TRA100620	●	
62	80	10	TRA200620	●	●
62	85	10	TRAA00620	●	●
62	90	10	TRAB00620	●	
62	95	10	TRA300620	●	
63	85	10	TRAA00630	●	●
65	80	8	TRA000650	●	
65	85	8	TRA200650		●
65	85	10	TRAA00650	●	●
65	90	7	TRAD00650		●
65	90	10	TRAB00650	●	●
65	95	10	TRA600650	●	
65	100	10	TRAC00650	●	●
65	110	10	TRA900650		●
68	85	10	TRA000680	●	
68	90	10	TRAA00680	●	●
70	85	7	TRA000700	●	
70	85	8	TRA100700	●	●
70	85	10	TRAC00700	●	
70	90	7	TRA800700	●	●
70	90	10	TRAA00700	●	●
70	95	10	TRA400700	●	
70	100	6	TRAJ00700	●	
70	100	10	TRAB00700	●	●
70	110	8	TRA900700	●	
70	110	12	TRAG00700	●	
72	95	10	TRAA00720	●	●
72	100	10	TRAB00720	●	
75	90	8	TRA000750	●	●
75	90	10	TRA100750	●	●
75	95	7	TRAD00750		●
75	95	10	TRAA00750	●	●
75	100	10	TRAB00750	●	●
75	110	10	TRA600750		●
75	115	10	TRA500750	●	
77	95.5	9.5	TRA000770	●	
78	100	10	TRAA00780	●	
80	95	8	TRA000800		●
80	100	7	TRAC00800		●
80	100	10	TRAA00800	●	●
80	100	13	TRA100800	●	●
80	105	13	TRA300800	●	
80	110	10	TRAB00800	●	●

Dimension			TSS Part No.	Material	
d <sub>1</sub>	d <sub>2</sub>	b		NBR	FKM
80	110	12	TRA400800		●
80	115	10	TRA600800	●	●
80	120	12	TRA700800		●
80	120	13	TRA900800	●	
85	100	9	TRA300850		●
85	105	12	TRAG00850		●
85	110	10	TRA100850	●	
85	110	12	TRAA00850	●	●
85	120	12	TRAB00850	●	●
88	110	12	TRA000880	●	
90	110	7.5	TRAE00900		●
90	110	8	TRA100900	●	
90	110	10	TRA200900	●	●
90	110	12	TRAA00900	●	●
90	115	12	TRAF00900		●
90	120	12	TRAB00900	●	●
90	130	13	TRA800900	●	
90	140	13	TRA900900	●	●
95	110	12	TRA500950		●
95	115	13	TRA100950	●	●
95	120	12	TRAA00950	●	●
95	125	12	TRAB00950	●	●
95	140	12	TRAC00950	●	●
95	145	13	TRA700950	●	
96	117	10	TRA000960		●
100	115	9	TRAG01000	●	●
100	120	6	TRAD01000	●	
100	120	7.5	TRAE01000		●
100	120	10	TRA001000	●	
100	120	12	TRAA01000	●	●
100	125	12	TRAB01000	●	●
100	130	12	TRAC01000	●	●
105	130	12	TRAA01050	●	●
105	140	12	TRAB01050	●	
105	140	13	TRA601050	●	
110	128	12	TRA501100		●
110	130	12	TRAA01100	●	●
110	130	13	TRA201100	●	●
110	140	12	TRAB01100	●	●
110	150	13	TRA801100	●	
115	135	10	TRA101150	●	●
115	140	12	TRAA01150	●	●

- In one of the preferred materials
- In other commercial materials





Dimension			TSS Part No.	Material		Dimension			TSS Part No.	Material	
d <sub>1</sub>	d <sub>2</sub>	b		NBR	FKM	d <sub>1</sub>	d <sub>2</sub>	b		NBR	FKM
115	140	13	TRA201150		●	180	200	15	TRA001800	●	
118	150	12	TRA101180	●		180	210	15	TAA01800	●	●
120	140	7.5	TRA901200	●		180	215	15	TRA401800	●	
120	140	13	TRA201200	●	●	180	215	16	TRA101800	●	
120	145	15	TRAF01200	●		184	216	16	TRA001840	●	
120	150	12	TAA01200	●	●	185	210	10	TRA001850		●
120	160	12	TRAB01200	●	●	185	210	13	TRA101850	●	
125	150	12	TAA01250	●	●	190	220	15	TAA01900	●	●
125	160	12	TRAB01250	●	●	190	220	12	TRA601900		●
127	146	11.2	TRA001270	●		190	225	16	TRA101900	●	
130	150	10	TRA001300	●	●	190	230	15	TRA301900		●
130	150	12	TRA801300		●	190	240	15	TRA501900	●	
130	160	12	TAA01300	●	●	191	216	12.7	TRA001910	●	
130	160	13	TRA101300	●	●	195	230	16	TRA001950	●	
130	160	15	TRA301300	●	●	200	230	15	TAA02000	●	●
130	170	12	TRAB01300	●	●	210	240	15	TAA02100	●	●
130	180	15	TRA401300		●	210	250	16	TRA102100	●	
135	170	12	TAA01350	●	●	215	235	10	TRA202150	●	
140	160	10	TRAE01400		●	220	250	15	TAA02200	●	●
140	160	12	TRA201400	●	●	220	270	15	TRA402200	●	
140	160	13	TRA001400	●	●	222	254	16	TRA002220	●	
140	165	12	TRA101400	●	●	230	260	15	TAA02300	●	●
140	170	12	TRA301400	●	●	240	270	15	TAA02400	●	●
140	170	13	TRA401400	●		240	280	15	TRA002400	●	
140	170	15	TAA01400	●	●	248	286	19	TRA002480	●	
140	180	12	TRA801400		●	250	280	15	TAA02500	●	●
145	175	15	TAA01450	●	●	250	290	16	TRA102500	●	
150	170	10	TRA401500	●		260	280	10	TRA202600	●	
150	170	15	TRA101500		●	260	290	15	TRA102600	○	
150	180	12	TRA201500	●	●	260	290	16	TRA002600	●	●
150	180	15	TAA01500	●	●	260	300	20	TAA02600	○	○
155	180	15	TRA101550	●		265	290	16	TRA002650	○	○
160	180	15	TRA001600		●	275	305	12	TRA002750	●	
160	185	10	TRA101600	●		280	310	15	TRA202800		○
160	185	14	TRAF01600	●		280	320	20	TAA02800	●	●
160	190	15	TAA01600	●	●	285.7	323.8	16	TRA002857	●	
160	200	12	TRA401600	●	●	290	330	20	TRA002900	●	
165	190	13	TRA001650	●	●	300	340	18	TRA103000		○
170	190	10	TRA301700	●		300	340	20	TAA03000	●	○
170	200	12	TRA201700	●	●	320	360	20	TAA03200	●	○
170	200	15	TAA01700	●	●	330	360	12	TRA103300	●	
175	200	10	TRA001750		●	340	380	18	TRA003400	●	○
175	205	15	TRAR01750		●						
178	203	11.2	TRA001780	●							

- In one of the preferred materials
- In other commercial materials



Dimension			TSS Part No.	Material	
d <sub>1</sub>	d <sub>2</sub>	b		NBR	FKM
340	380	20	TRAA03400	○	○
350	390	18	TRAA03500	●	●
360	400	20	TRAA03600	○	
370	410	15	TRAA03700	○	○
380	420	20	TRAA03800	○	○
385	425	15	TRAA03850	○	
394	420	16	TRAA03940	○	
400	440	20	TRAA04000	○	○
420	450	15	TRAA04200	●	
420	460	20	TRAA04200	○	○
440	480	20	TRAA04400	○	○
480	520	20	TRAA04800	○	○
500	540	20	TRAA05000	○	○
560	610	20	TRAA05600	○	
670	710	20	TRAA06700	○	
800	840	20	TRAA08000	○	

- In one of the preferred materials
- In other commercial materials



## ■ Type TRE

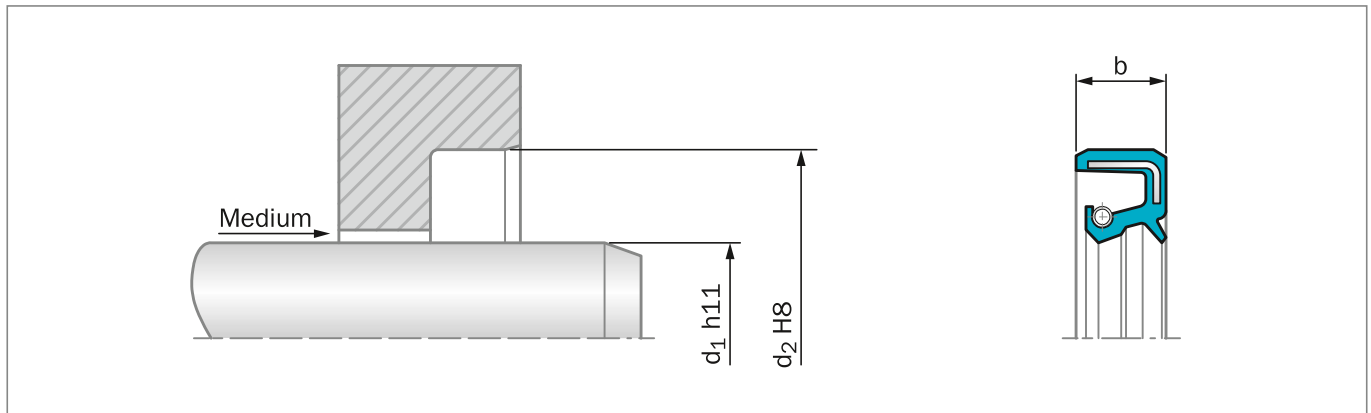

Figure 15: Installation Drawing

### GENERAL DESCRIPTION

Trelleborg Sealing Solutions Type TRE are seals with completely rubber covered outer diameters. Two different O.D. design are available: Flat rubber sheath and wavy. The additional dust lip protects the main sealing lip against dust and other fine solid contaminants and therefore this type is recommended for use in polluted environments. To achieve a long lifetime, a suitable lubricant between the two sealing lips should be applied.

### ADVANTAGES

- Good static sealing
- Compensation of different thermal expansion
- Reduced risk of fretting corrosion
- Effective protection against air side contaminants
- Higher bore surface roughness is allowed
- Installation in split-housings
- Modern lip design provides low radial forces

### APPLICATION EXAMPLES

- Transmission systems (e.g. gearboxes)
- Pumps
- Electrical motors
- Machine tools

### OPERATING CONDITIONS

<b>Pressure:</b>	Up to 0.05 MPa
<b>Temperature:</b>	-40 °C to +200 °C (depending on material)
<b>Speed:</b>	Up to 10 m/s (depending on material)
<b>Media:</b>	Mineral and synthetic lubricants (CLP, HLP, APGL etc.)

Trelleborg Sealing Solutions has carried out several thousand compatibility tests. Please ask your local Trelleborg Sealing Solutions marketing company for details.

### IMPORTANT NOTE

The above data are maximum values and cannot be used at the same time, e.g. the maximum operating speed depends on material type, pressure and temperature.



**Table 8: Materials**

TSS Compound Reference	Standard Compound	Temperature °C	Standard Metal Insert	Standard Spring
N7MMR	NBR (70 Shore A)	-30 °C - 100 °C	Carbon steel	Carbon steel
4N011/4NV11	NBR (75 Shore A)	-30 °C - 100 °C	Carbon steel	Carbon steel
VCBVR	FKM (70 Shore A)	-20 °C - 200 °C	Carbon steel	Stainless steel
4V012	FKM (75 Shore A)	-20 °C - 200 °C	Carbon steel	Stainless steel

Special grades and other materials (ACM, EACM, EPDM, HNBR, VMQ) on request.  
Metal insert, and spring as well, can be supplied in different materials on request.

**ORDERING EXAMPLE OIL SEAL TSS TYPE**

<b>TSS Type:</b>	E
<b>Code:</b>	TRE
<b>Dimensions:</b>	Shaft diameter 15 mm Housing diameter 30 mm Width 7 mm
<b>Material:</b>	NBR
<b>Material Code:</b>	N7MMR

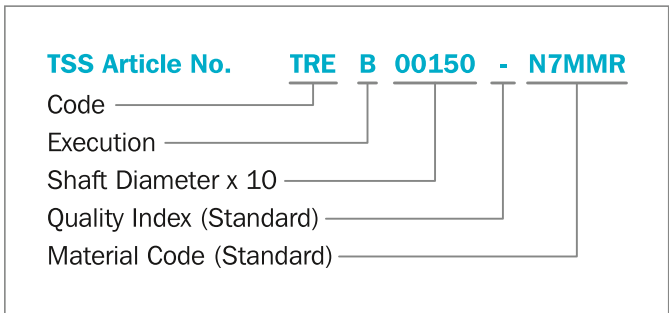

**Table 9: Preferred Series / Dimension, TSS Part Numbers**

Dimension			TSS Part No.	Material	
d <sub>1</sub>	d <sub>2</sub>	b		NBR	FKM
6	16	5	TRE000060	●	
6	16	7	TREA00060	●	
8	16	5	TRE500080		
8	16	7	TRE000080	●	
8	18	5	TRE300080		●
8	22	7	TRE100080	●	
10	18	6	TRE100100	●	
10	19	7	TRE200100	●	
10	20	5	TRE300100	●	
10	22	7	TREA00100	●	
10	26	7	TREC00100	●	
11	17	4	TRE000110	●	
12	19	5	TRE000120	●	●
12	20	5	TRE400120	●	
12	22	7	TREA00120	●	●
12	25	7	TREE00120	●	
12	28	7	TREC00120	●	●
12	32	7	TRE300120	●	●
12	37	10	TRE900120	●	
14	21	4	TRE300140	●	
14	22	4	TRE400140		●
14	23	5	TRE100140		●
14	24	7	TREA00140	●	●

Dimension			TSS Part No.	Material	
d <sub>1</sub>	d <sub>2</sub>	b		NBR	FKM
14	35	7	TRED00140		●
15	24	5	TREH00150	●	
15	24	7	TRE000150	●	
15	25	5	TRE600150		●
15	26	7	TREA00150	●	
15	28	7	TRE100150	●	
15	30	7	TREB00150	●	●
15	30	10	TRE700150		●
15	32	7	TREC00150	●	●
15	35	7	TRED00150	●	
15	42	7	TRE300150	●	
16	22	7	TRE500160	●	
16	28	7	TREA00160	●	●
16	29	4	TRE400160	●	
16	30	7	TREB00160	●	●
16	32	7	TREC00160		●
17	28	6	TRE000170	●	
17	28	7	TREA00170	●	●
17	30	7	TREB00170	●	●
17	35	7	TRED00170	●	
17	40	7	TREE00170	●	●

● In one of the preferred materials  
○ In other commercial materials



Dimension			TSS Part No.	Material		Dimension			TSS Part No.	Material	
d <sub>1</sub>	d <sub>2</sub>	b		NBR	FKM	d <sub>1</sub>	d <sub>2</sub>	b		NBR	FKM
17	42	7	TRE200170	●		25	44	7	TREQ00250		●
18	28	7	TRE000180	●		25	47	7	TRED00250	●	●
18	30	6	TRE400180	●		25	47	10	TRE700250	●	
18	30	7	TREA00180	●		25	52	7	TREE00250	●	●
18	32	7	TREB00180	●	●	25	52	10	TRE900250	●	
18	47	6	TRE800180	●		25	62	7	TREG00250	●	●
18	47	10	TRE900180	●		26	37	7	TREA00260	●	
20	30	5	TRES00200			26	52	8	TRE100260	●	
20	30	7	TREA00200	●	●	27	37	7	TRE200270	●	
20	32	7	TREB00200	●		28	38	7	TRE700280		●
20	34	7	TRE100200	●		28	40	7	TREA00280	●	●
20	35	7	TREC00200	●	●	28	45	7	TREE00280		●
20	36	7	TRE200200	●		28	47	7	TREB00280	●	
20	40	7	TRED00200	●		28	47	10	TRE400280	●	
20	42	7	TRE300200	●	●	29	52	7	TRE100290	●	
20	47	7	TREE00200	●	●	30	40	7	TREA00300	●	●
20	52	7	TRE600200	●		30	42	6	TRE000300	●	
20	52	8	TREG00200		●	30	42	7	TREB00300	●	●
20	55	7	TREF00200	●	●	30	42	8	TRE100300	●	
20	62	7	TRER00200		●	30	43	8	TRER00300	●	
21.4	29.5	4	TRE000214	●		30	45	8	TRE200300	●	
22	28	4	TRE700220	●	●	30	47	7	TREC00300	●	●
22	32	7	TREA00220	●	●	30	47	8	TREK00300	●	●
22	35	7	TREB00220	●	●	30	50	7	TRE300300	●	●
22	37	7	TRE000220		●	30	50	8	TREP00300	●	
22	40	7	TREC00220	●	●	30	50	10	TRE600300	●	
22	52	7	TRE600220	●		30	52	7	TRED00300	●	●
22	52	10	TREG00220		●	30	52	10	TRE700300	●	
22	62	6	TRE800220	●		30	55	7	TRE800300	●	●
22	62	10	TREE00220	●		30	55	10	TRE900300	●	
23	32	5	TRE100230	●	●	30	62	7	TREE00300	●	●
23	34	5	TRE200230	●	●	30	62	10	TREF00300	●	●
24	32	7	TRE000240	●		30	72	10	TREG00300	●	●
24	35	7	TREA00240	●		30	80	10	TREI00300	●	
24	40	7	TREC00240	●	●	32	42	5	TRE300320	●	
24	47	7	TRED00240	●	●	32	42	7	TRE800320		
25	32	6	TRER00250		●	32	45	7	TREA00320	●	
25	35	6	TRE000250	●		32	47	7	TREB00320	●	●
25	35	7	TREA00250	●	●	32	50	10	TRE100320	●	
25	38	8	TREK00250	●		32	52	7	TREC00320	●	●
25	40	5	TREF00250	●		32	80	7	TREM00320	●	
25	40	7	TREB00250	●		34	65	8	TRE400340		●
25	40	8	TRE100250	●							
25	42	7	TREC00250	●							

- In one of the preferred materials
- In other commercial materials



Dimension			TSS Part No.	Material	
d <sub>1</sub>	d <sub>2</sub>	b		NBR	FKM
35	42	4	TREX00350		●
35	45	7	TRE000350	●	
35	47	7	TREA00350	●	●
35	47	8	TRES00350	●	
35	50	7	TREB00350	●	
35	50	8	TREW00350	●	
35	50	10	TREL00350	●	
35	52	6	TRE100350	●	
35	52	7	TREC00350	●	●
35	52	10	TRE200350	●	
35	55	8	TREK00350	●	
35	56	10	TRE300350	●	
35	58	10	TREG00350	●	●
35	62	7	TRED00350	●	
35	62	8	TREU00350	●	
35	62	10	TRE400350	●	●
35	62	12	TRE500350		●
35	65	10	TRE600350	●	
35	65	12	TREP00350	●	
35	72	7	TREH00350		●
35	72	8	TREJ00350	●	
35	72	10	TRE700350	●	●
35	72	12	TRE800350	●	●
35	80	12	TRE000350	●	
36	52	6.3	TRE200360	●	
36	54	7	TRE100360	●	
37	62	7	TRE100370		●
37.5	75	8	TRE000375	●	
38	52	7	TREA00380	●	
38	55	8	TRE100380		●
38	62	7	TREC00380	●	●
38	62	10	TRE500380	●	
38	69	9.5	TREH00380	●	
38	72	10	TRED00380	●	●
38	80	8	TREG00380		●
40	52	5	TRE000400	●	
40	52	7	TREA00400	●	●
40	55	6	TRE000400	●	
40	55	7	TREB00400	●	●
40	55	8	TRE100400	●	●
40	56	8	TREG00400	●	●
40	60	10	TRE400400	●	●
40	62	6	TREMGE003	●	
40	62	7	TREC00400	●	●

Dimension			TSS Part No.	Material	
d <sub>1</sub>	d <sub>2</sub>	b		NBR	FKM
40	62	10	TRE600400	●	●
40	62	12	TREJ00400	●	
40	65	8	TREM00400	●	
40	68	7	TRE700400	●	
40	68	8	TREY00400		●
40	68	10	TREW00400		●
40	72	7	TRED00400	●	●
40	72	10	TRE800400	●	
40	80	7	TRE900400	●	
40	80	10	TREF00400	●	●
40	90	12	TREH00400	●	●
40	90	13.5	TRE000400	●	
42	62	7	TRE300420	●	
42	62	10	TRE800420		●
42	72	8	TREC00420	●	
42	72	10	TRE600420	●	●
44	65	10	TRE000440		●
45	52	4	TREX00450	●	
45	55	7	TREL00450	●	
45	60	7	TRE000450	●	●
45	60	8	TREA00450	●	
45	62	7	TRE100450	●	●
45	62	8	TREB00450	●	●
45	65	7	TREU00450		●
45	65	8	TREC00450	●	●
45	65	10	TRE300450	●	●
45	68	10	TRE500450	●	
45	70	10	TRE000450	●	
45	72	8	TRED00450	●	●
45	75	7	TRE800450	●	●
45	75	8	TREI00450	●	●
45	75	10	TRE900450	●	●
45	80	10	TREF00450	●	
45	85	8	TRET00450	●	
45	85	10	TREG00450	●	●
45	90	10	TREH00450	●	●
45	100	8	TREW00450	●	
47	90	10	TRE000470	●	
48	62	8	TREA00480	●	●
48	65	10	TRE000480	●	
48	68	10	TRE100480	●	
48	70	10	TRE500480		●

- In one of the preferred materials
- In other commercial materials



Dimension			TSS Part No.	Material		Dimension			TSS Part No.	Material	
d <sub>1</sub>	d <sub>2</sub>	b		NBR	FKM	d <sub>1</sub>	d <sub>2</sub>	b		NBR	FKM
48	72	7	TRE200480	●		60	75	6	TREJ00600	●	
48	72	8	TREB00480	●		60	75	8	TREA00600	●	●
48	72	10	TRE700480		●	60	80	6	TREE00600	●	
48	72	12	TRE300480	●		60	80	8	TREB00600	●	●
48	90	13	TRE600480	●		60	80	10	TRE100600	●	●
50	62	7	TRE200500	●		60	82	9	TRE200600	●	
50	65	8	TREA00500	●	●	60	85	8	TREC00600	●	●
50	68	7	TREK00500	●		60	85	10	TRE300600	●	
50	68	8	TREB00500	●	●	60	90	8	TRED00600	●	●
50	68	9	TREG00500			60	90	8	TREN00600	●	
50	70	10	TRE100500	●	●	60	90	10	TRE400600		●
50	72	7	TREF00500	●		60	95	8	TREK00600		●
50	72	8	TREC00500	●	●	60	95	10	TRE500600	●	
50	72	10	TRE300500	●	●	60	100	10	TREM00600	●	●
50	75	10	TRE500500	●	●	60	110	8	TRE900600	●	
50	80	8	TRED00500	●	●	60	110	10	TRE700600	●	●
50	80	10	TRE600500	●		60	110	13	TREG00600	●	
50	90	8	TRE800500	●	●	62	110	10	TRE100620	●	
50	90	10	TRE900500	●	●	62	120	12	TRE200620	●	
50	100	10	TREM00500		●	64	85	10	TRE100640		●
50	110	10	TREH00500		●	65	80	8	TRE00650	●	●
52	62	8	TRE600520		●	65	85	10	TREA00650	●	●
52	68	8	TREA00520	●	●	65	85	12	TREG00650	●	
52	72	8	TREB00520	●	●	65	85	13	TRE300650		●
52	85	10	TRE400520	●		65	90	10	TREB00650	●	●
52	100	10	TRE500520	●		65	100	10	TREC00650	●	●
55	68	8	TRE000550	●		65	110	10	TRED00650	●	●
55	70	8	TREA00550	●	●	65	120	13	TREF00650	●	
55	72	7	TREE00550	●		68	90	10	TREA00680	●	
55	72	8	TREB00550	●	●	68	92	10	TRE400680	●	
55	72	10	TRE200550	●	●	68	110	13	TRE100680	●	
55	75	8	TRE300550	●	●	70	85	8	TRE000700	●	
55	75	12	TRE500550	●		70	90	7	TRE800700	●	
55	80	8	TREC00550	●	●	70	90	10	TREA00700	●	●
55	80	10	TRE600550	●	●	70	100	10	TREB00700	●	●
55	85	10	TRE700550	●		70	110	8	TRE700700	●	
55	90	5	TRE100550	●		70	110	13	TRE400700	●	
55	90	8	TREG00550	●	●	70	125	12	TRE600700	●	
55	90	10	TRE800550	●		70	160	12	TREG00700	●	
55	100	8	TRED00550	●	●	72	86	7	TRE100720	●	
55	100	10	TRE900550	●		72	95	10	TREA00720	●	
57	80	12	TRE000570		●	72	95	12	TRE000720	●	
58	80	10	TRE000580	●	●						
60	72	8	TRELO0600	●	●						

- In one of the preferred materials
- In other commercial materials



Dimension			TSS Part No.	Material	
d <sub>1</sub>	d <sub>2</sub>	b		NBR	FKM
72	100	10	TREB00720		●
72	110	13	TRE400720	●	
72	140	12	TRE300720	●	
75	90	8	TRE400750	●	
75	90	10	TREC00750		●
75	95	9	TRE600750	●	
75	95	10	TREA00750	●	●
75	100	10	TREB00750	●	●
75	110	10	TRED00750		●
75	115	10	TRE800750	●	
75	120	12	TRE300750	●	
78	100	10	TREA00780	●	
79	120	13	TRE000790	●	
80	95	8	TREC00800	●	
80	100	7	TRE000800	●	●
80	100	10	TREA00800	●	●
80	100	13	TRE100800	●	●
80	105	13	TRE200800	●	●
80	110	10	TREB00800	●	
80	115	10	TRE300800	●	●
80	120	13	TRE400800	●	
80	140	13	TRE900800	●	
80	140	15	TRE600800	●	
85	105	12	TRE800850		●
85	110	12	TREA00850	●	●
85	110	13	TRE200850		●
85	120	12	TREB00850	●	●
85	130	10	TRE400850	●	
85	130	12	TRE700850	●	●
85	132	12	TRED00850		●
85	140	12	TREG00850		●
85	150	12	TRE600850	●	
90	110	7.5	TRE800900	●	●
90	110	8	TRE600900	●	●
90	110	12	TREA00900	●	●
90	120	12	TREB00900	●	●
90	120	13	TRE200900	●	●
90	125	13	TRE700900	●	●
90	140	12	TRE400900	●	
95	110	12	TREC00950		●
95	115	12	TRE000950	●	
95	120	12	TREA00950	●	●
95	120	13	TRE200950	●	●
95	125	12	TREB00950	●	●

Dimension			TSS Part No.	Material	
d <sub>1</sub>	d <sub>2</sub>	b		NBR	FKM
95	130	13	TRE300950	●	
95	140	12	TRED00950		●
97	112	8	TRE000970	●	
100	120	10	TRE001000	●	
100	120	12	TREA01000	●	●
100	125	12	TREB01000	●	
100	125	13	TRE101000	●	
100	130	12	TREC01000	●	
100	130	13	TRE201000	●	●
100	140	12	TRE701000	●	
100	150	12	TRE501000	●	
100	160	14	TRE301000		●
100	180	12	TRE401000	●	
105	120	7	TRE001050	●	
105	125	13	TRE101050	●	
105	130	12	TREA01050	●	●
105	140	12	TREB01050	●	●
110	130	12	TREA01100	●	
110	140	12	TREB01100	●	●
110	140	13	TRE401100	●	●
110	150	13	TRE601100	●	
110	165	12	TRE001100		●
110	170	14	TRE301100	●	
110	215	15	TRE701100	●	
115	130	12	TRE101150	●	
115	140	12	TREA01150	●	●
115	150	12	TREB01150	●	●
115	160	12	TRE301150		●
117	200	15	TRE001170		●
118	150	12	TRE001180	●	
120	140	7.5	TRE701200	●	
120	140	13	TRE001200	●	●
120	142	12	TRE501200	●	
120	150	12	TREA01200	●	●
120	150	15	TRE201200	●	●
120	160	12	TREB01200	●	
120	160	15	TRE601200	●	
120	180	15	TRE401200	●	●
125	150	12	TREA01250	●	●
125	155	14	TRE301250	●	
127	158.75	17.46	TRE001270		●
130	150	10	TREF01300		●

- In one of the preferred materials
- In other commercial materials





Dimension			TSS Part No.	Material		Dimension			TSS Part No.	Material	
d <sub>1</sub>	d <sub>2</sub>	b		NBR	FKM	d <sub>1</sub>	d <sub>2</sub>	b		NBR	FKM
130	150	12	TRE301300		●	185	210	13	TRE101850	●	
130	160	7.5	TRE401300	●		190	215	15	TRE401900	●	
130	160	12	TREA01300	●	●	190	220	12	TRE001900	●	
130	160	15	TRE001300	●	●	190	220	15	TREA01900	●	●
130	170	12	TREB01300	●		195	215	15	TRE201950	●	
132	152	6	TRE101320	●		200	225	8.5	TRE202000	●	
135	160	15	TRE001350	●		200	230	15	TREA02000	●	●
135	170	10	TRE301350	●		210	240	15	TREA02100	●	
135	170	12	TREA01350	●	●	220	250	15	TREA02200	●	●
140	160	10	TRE801400	●		230	260	15	TREA02300	●	
140	160	12	TRE601400		●	240	270	15	TREA02400	●	○
140	160	13	TRE001400	●		240	320	20	TRE002400		●
140	170	12	TRE201400	●		250	280	11	TRE102500	●	
140	170	13	TRE901400		●	250	280	15	TREA02500	●	●
140	170	15	TREA01400	●		260	280	16	TRE002600	●	●
140	180	12	TRE501400		●	260	290	16	TRE102600	●	●
140	210	15	TRE301400	●		260	300	20	TREA02600	●	●
144	160	12	TRE001440	●		265	290	15	TRE002650	●	
145	175	15	TREA01450	●	●	280	320	20	TREA02800	●	●
150	170	10	TRE101500		●	300	340	16	TRE103000	●	○
150	170	12	TRE301500		●	300	340	20	TREA03000	○	○
150	180	15	TREA01500	●	●	320	360	20	TREA03200	○	○
155	174	12	TRE401550		●	350	380	16	TRE003500	●	●
155	180	15	TRE001550	●	●	360	400	20	TREA03600	○	○
155	190	13	TRE301550		●	380	420	20	TREA03800	○	
160	185	15	TRE601600	●	●	394	420	16	TRE003940	○	
160	190	15	TREA01600	●	●	420	450	12	TRE104200	●	
160	200	15	TRE001600	●		420	460	20	TREA04200	○	
160	210	15	TRE401600	●		440	480	20	TREA04800	○	
160	240	14	TRE701600	●		920	970	20	TRE009200		
165	190	8	TRE101650	●							
165	190	13	TRE201650	●	●						
166	179	8	TRE001660		●						
170	185	9.5	TRE301700		●						
170	195	7.5	TRE401700	●							
170	200	15	TREA01700	●	●						
174	190	5	TRE001740	●							
175	205	15	TRE001750	●							
178	205	15	TREA01780	●							
180	200	13	TRE101800	●							
180	210	15	TREA01800	●	●						
180	215	15	TRE201800	●							
180	215	16	TRE501800		●						
180	220	16	TRE401800	●							

- In one of the preferred materials
- In other commercial materials



## ■ Type TRC

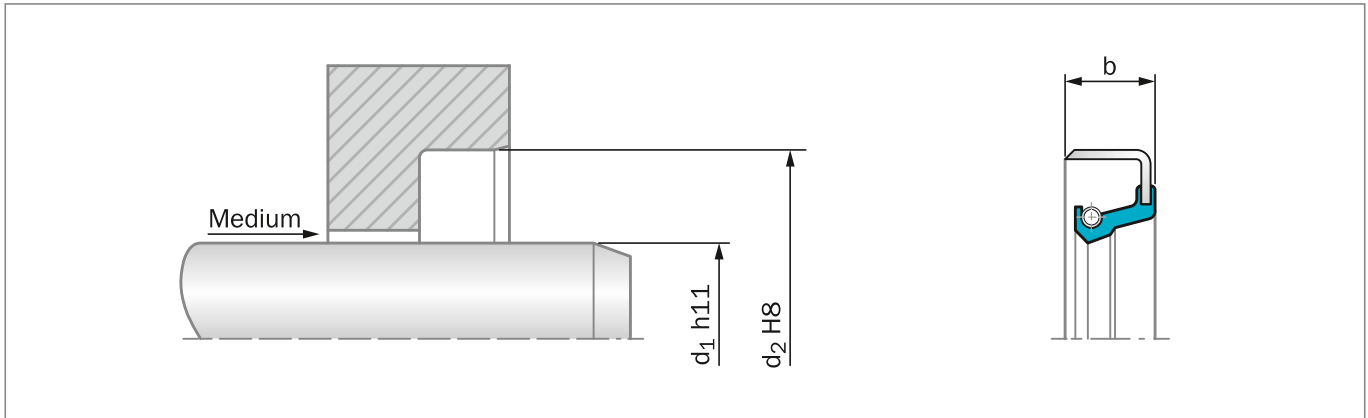

Figure 16: Installation Drawing

### GENERAL DESCRIPTION

Trelleborg Sealing Solutions Type TRC are metal cased radial lip seals. This type is not recommended for use in heavily polluted environments. As the static sealing between housing and metallic shell is limited, low viscosity media can "creep". Better performance can be achieved with Epoxy-based resin O.D. coating. This special treatment is on request.

### ADVANTAGES

- Good radial stiffness, especially for large diameters
- Good fitting stability avoiding pop-out of the seal
- Modern lip design provides low radial forces
- Cost effective
- Suitable for use in combination with axial seal (V-Ring and GAMMA-seal)

### APPLICATION EXAMPLES

- Transmission systems (e.g. gearboxes)
- Pumps
- Electrical motors
- Machine tools
- Heavy engineering applications

### OPERATING CONDITIONS

<b>Pressure:</b>	Up to 0.05 MPa
<b>Temperature:</b>	-40 °C to +200 °C (depending on material)
<b>Speed:</b>	Up to 10 m/s (depending on material)
<b>Media:</b>	Mineral and synthetic lubricants (CLP, HLP, APGL etc.)

Trelleborg Sealing Solutions has carried out several thousand compatibility tests. Please ask your local Trelleborg Sealing Solutions marketing company for details.

### IMPORTANT NOTE

The above data are maximum values and cannot be used at the same time, e.g. the maximum operating speed depends on material type, pressure and temperature.



Table 10: Materials

TSS Compound Reference	Standard Compound	Temperature °C	Standard Metal Insert	Standard Spring
N7MMR	NBR (70 Shore A)	-30 °C - 100 °C	Carbon steel	Carbon steel
4N011/4NV11	NBR (75 Shore A)	-30 °C - 100 °C	Carbon steel	Carbon steel
VCBVR	FKM (70 Shore A)	-20 °C - 200 °C	Carbon steel	Stainless steel
4V012	FKM (75 Shore A)	-20 °C - 200 °C	Carbon steel	Stainless steel

Special grades and other materials (ACM, EACM, EPDM, HNBR, VMQ) on request.  
Metal insert, and spring can be supplied in different materials on request.

## ORDERING EXAMPLE OIL SEAL TSS TYPE

<b>TSS Type:</b>	C
<b>Code:</b>	TRC
<b>Dimensions:</b>	Shaft diameter 20 mm Housing diameter 35 mm Width 7 mm
<b>Material:</b>	NBR
<b>Material Code:</b>	N7MMR

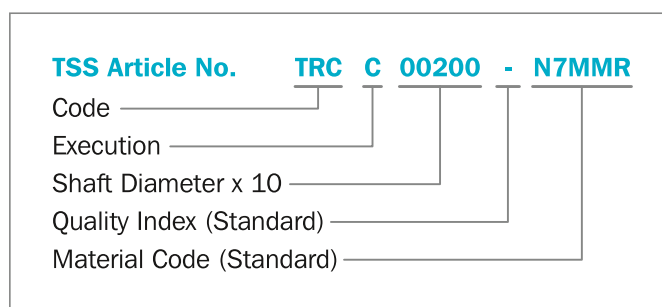

Table 11: Preferred Series / Dimension, TSS Part Numbers

Dimension			TSS Part No.	Material	
d <sub>1</sub>	d <sub>2</sub>	b		NBR	FKM
8	16	7	TRC000080	●	
10	22	7	TRCA00100	●	
11	17	4	TRC000110	●	
12	22	7	TRCA00120	●	
12	24	7	TRCB00120	●	
12	28	7	TRCC00120	●	
20	30	5	TRC100200		●
20	30	7	TRCA00200	●	
20	32	7	TRCB00200	●	●
20	35	7	TRCC00200	●	
20	40	7	TRCD00200	●	
20	42	7	TRC300200	●	●
20	47	7	TRCE00200	●	
24	35	7	TRCA00240	●	
25	47	7	TRCD00250	●	
30	40	7	TRCA00300	●	
30	42	7	TRCB00300	●	
30	62	7	TRCE00300	●	
35	45	7	TRC000350	●	●
35	47	7	TRCA00350	●	
35	56	12	TRC500350	●	
35	62	12	TRC700350	●	
38	52	7	TRCA00380	●	●
38	52	9	TRC400380	●	
40	52	7	TRCA00400	●	
42	55	7	TRC000420	●	
45	55	7	TRC000450	●	
45	60	10	TRC200450	●	
45	62	7	TRC300450	●	
45	62	8	TRCB00450	●	
49	65	10	TRC000490	●	
49	68	12	TRC100490	●	
50	62	7	TRC000500	●	
50	65	8	TRCA00500	●	
50	68	8	TRCB00500	●	
50	80	8	TRCD00500	●	
55	70	8	TRCA00550	●	
60	70	7	TRC000600	●	
60	72	8	TRC100600	●	
60	75	8	TRCA00600	●	
65	80	8	TRC000650	●	
68	90	10	TRCA00680		●

● In one of the preferred materials  
○ In other commercial materials



Dimension			TSS Part No.	Material	
d <sub>1</sub>	d <sub>2</sub>	b		NBR	FKM
70	90	10	TRCA00700	●	
70	100	10	TRCB00700	●	
75	95	5	TRC000750	●	
75	100	10	TRCB000750	●	
76	110	13	TRC000760	●	
80	100	10	TRCA00800	●	
80	110	10	TRCB00800	●	
80	115	13	TRC200800	●	
85	100	9	TRC000850	●	
85	105	10	TRC100850	●	
90	110	8	TRC000900	●	
95	110	10	TRC300950	●	
100	115	9	TRC001000	●	
100	120	12	TRCA01000	●	
105	125	12	TRC001050	●	
110	126	9	TRC101100		●
110	130	8	TRC301100		●
120	140	13	TRC001200	●	
130	160	13	TRC001300	●	
140	160	13	TRC101400	●	
170	200	15	TRCA01700	●	
180	200	12	TRC201800	●	
180	215	16	TRC101800	●	
190	215	15	TRC001900	●	
250	280	15	TRCA02500	●	
270	310	16	TRC002700	○	
350	380	16	TRC003500	○	
370	410	15	TRC003700		○
370	410	15	TRC003700	○	
400	440	20	TRCA04000		○
440	480	20	TRCA04400	○	
460	500	20	TRCA04600	○	
460	500	20	TRCA04600		○

- In one of the preferred materials
- In other commercial materials



## ■ Type TRD

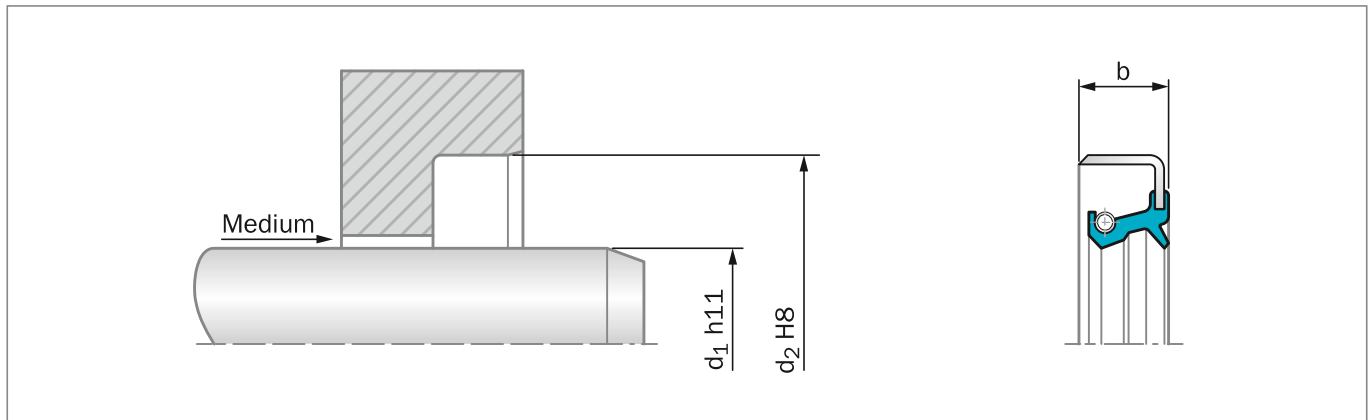

Figure 17: Installation Drawing

### GENERAL DESCRIPTION

Trelleborg Sealing Solutions Type TRD are metal cased radial lip seals. The additional dust lip protects the main sealing lip against dust and other fine solid contaminants and therefore this type is recommended for use in polluted environments. To achieve a long lifetime a suitable lubricant between the two sealing lips should be applied. As the static sealing between housing and metallic shell is somewhat limited, low viscosity media can "creep". Better performance can be achieved with epoxy based resin O.D. coating. This special treatment is on request.

### ADVANTAGES

- Effective protection against air side contaminants
- Good radial stiffness, especially for large diameters
- Good fitting stability avoiding pop-out of the seal
- Modern lip design provides low radial forces
- Cost effective

### APPLICATION EXAMPLES

- Transmission systems (e.g. gearboxes)
- Pumps
- Electrical motors
- Machine tools
- Heavy engineering applications

### OPERATING CONDITIONS

<b>Pressure:</b>	Up to 0.05 MPa
<b>Temperature:</b>	-40 °C to +200 °C (depending on material)
<b>Speed:</b>	Up to 10 m/s (depending on material)
<b>Media:</b>	Mineral and synthetic lubricants (CLP, HLP, APGL etc.)

Trelleborg Sealing Solutions has carried out several thousand compatibility tests. Please ask your local Trelleborg Sealing Solutions marketing company for details.

### IMPORTANT NOTE

The above data are maximum values and cannot be used at the same time, e.g. the maximum operating speed depends on material type, pressure and temperature.





## ■ Type TRB

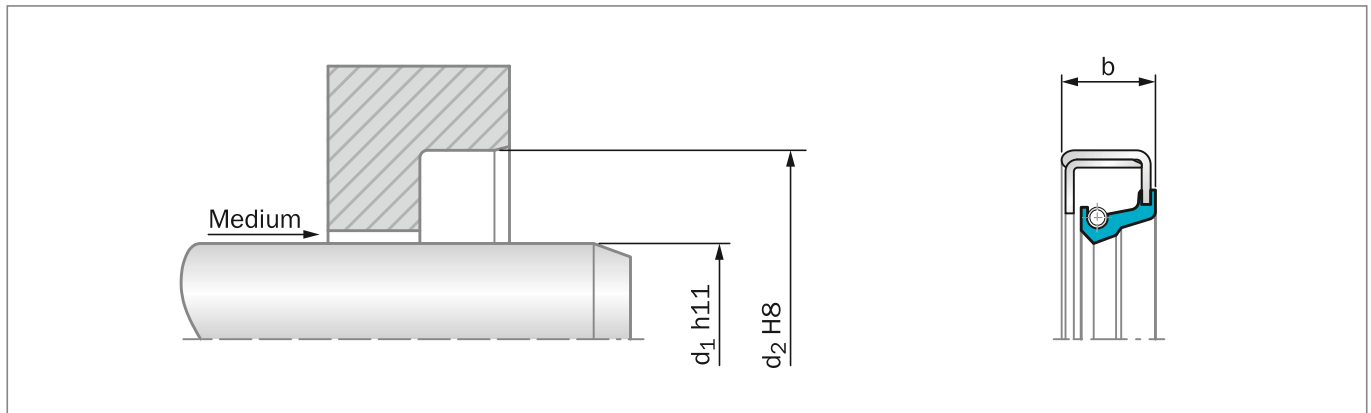

Figure 18: Installation Drawing

### GENERAL DESCRIPTION

Trelleborg Sealing Solutions Type TRB are reinforced metal cased radial lip seals. The supplementary metal inner ring provides a superior stiffness. This type is not recommended for use in heavily polluted environments. As the static sealing between housing and metallic shell is limited, low viscosity media can "creep". Better performance can be achieved with epoxy based resin O.D. coating. This special treatment is on request.

### ADVANTAGES

- Superior radial stiffness, especially for very large diameters
- Very good fitting stability avoiding pop-out of the seal
- Modern lip design provides low radial forces
- Cost effective
- Suitable for use in combination with axial seal (V-Ring and GAMMA-seal)
- Electrical motors
- Machine tools
- Heavy engineering applications (e.g. mills in steel industry)

### OPERATING CONDITIONS

<b>Pressure:</b>	Up to 0.05 MPa
<b>Temperature:</b>	-40 °C to +200 °C (depending on material)
<b>Speed:</b>	Up to 10 m/s (depending on material)
<b>Media:</b>	Mineral and synthetic lubricants (CLP, HLP, APGL etc.)

Trelleborg Sealing Solutions has carried out several thousands compatibility tests. Please ask your local Trelleborg Sealing Solutions marketing company for details.

### IMPORTANT NOTE

The above data are maximum values and cannot be used at the same time, e.g. the maximum operating speed depends on material type, pressure and temperature.



**Table 14: Materials**

TSS Compound Reference	Standard Compound	Temperature °C	Standard Metal Insert	Standard Spring
N7MMR	NBR (70 Shore A)	-30 °C - 100 °C	Carbon steel	Carbon steel
4N011/4NV11	NBR (75 Shore A)	-30 °C - 100 °C	Carbon steel	Carbon steel
VCBVR	FKM (70 Shore A)	-20 °C - 200 °C	Carbon steel	Stainless steel
4V012	FKM (75 Shore A)	-20 °C - 200 °C	Carbon steel	Stainless steel

Special grades and other materials (ACM, EACM, EPDM, HNBR, VMQ) on request.  
Metal insert, and spring as well, can be supplied in different materials on request.

**ORDERING EXAMPLE OIL SEAL TSS TYPE**

<b>TSS Type:</b>	B
<b>Code:</b>	TRB
<b>Dimensions:</b>	Shaft diameter 45 mm Housing diameter 60 mm Width 7 mm
<b>Material:</b>	NBR
<b>Material Code:</b>	N7MMR

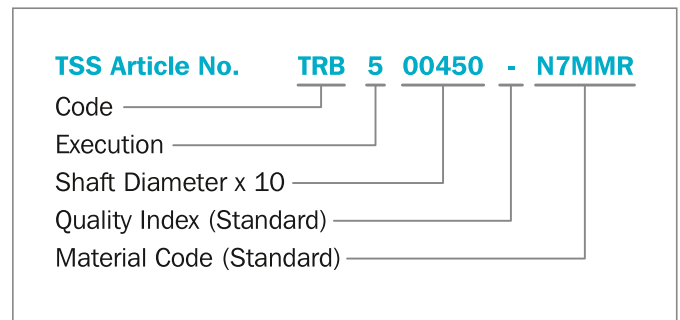

**Table 15: Preferred Series / Dimension, TSS Part Numbers**

Dimension			TSS Part No.	Material	
d <sub>1</sub>	d <sub>2</sub>	b		NBR	FKM
30	47	9	TRB800300	●	
30	47	10	TRB100300	●	
30	50	10	TRB300300	●	
30	62	10	TRB600300	●	
35	56	10	TRB300350		●
40	60	10	TRB200400	●	
45	60	10	TRB500450	●	
45	65	10	TRB200450	●	
45	72	10	TRB600450	●	
45	72	12	TRB000450	●	
50	72	12	TRB700500	●	○
50	90	10	TRBE00500	●	
50.80 (2.00")	73.10 (2.88")	12.70 (0.50")	TRB000508	●	
60	80	10	TRB000600	●	●
65	90	10	TRBB00650	●	
65.10 (2.56")	92.20 (3.63")	12.70 (0.50")	TRB000651	●	
66.70 (2.63")	88.50 (3.48")	12.70 (0.50")	TRB000667	●	
66.70 (2.63")	92.20 (3.63")	12.70 (0.50")	TRB100667	●	
69.85 (2.75")	90.12 (3.55")	12.70 (0.50")	TRB000698	●	
70	105	13	TRB400700	●	
73.02 (2.87")	95.40 (3.76")	12.70 (0.50")	TRB100730	●	
75	100	10	TRBB00750	●	

● In one of the preferred materials      ○ In other commercial materials      Values in brackets are inch sizes.





Dimension			TSS Part No.	Material	
d <sub>1</sub>	d <sub>2</sub>	b		NBR	FKM
75	100	12	TRB400750	●	○
75	105	13	TRBF00750	○	
75	115	13	TRB300750	●	
76.20 (3.00")	95.40 (3.76")	12.70 (0.50")	TRB000762	●	
76.20 (3.00")	98.60 (3.88")	11.90 (0.47")	TRB100762	●	
76.20 (3.00")	101.80 (4.00")	11.90 (0.47")	TRB200762	●	
80	100	10	TRBA00800	●	
80	100	12	TRB000800	●	●
80	110	12	TRB200800	●	
80	120	13	TRB400800	●	
85	130	13	TRB400850	●	
85.72 (3.37")	108.05 (4.25")	12.70 (0.50")	TRB000857	●	
90	130	13	TRB500900	●	
95	120	12	TRBA00950		●
98.42 (3.87")	120.81 (4.76")	12.70 (0.50")	TRB000984	●	
98.42 (3.87")	127.10 (5.00")	11.91 (0.47")	TRB100984	●	
100	120	12	TRBA01000		○
100	120	13	TRB101000	●	
101.60 (4.00")	127.10 (5.00")	12.70 (0.50")	TRB101016	●	●
114.30 (4.50")	139.85 (5.50")	12.70 (0.50")	TRB001143	●	
125	150	15	TRB301250	●	
127.00 (5.00")	158.90 (6.25")	12.70 (0.50")	TRB001270	●	
130	160	15	TRB401300	○	
130	180	15	TRB301300	●	
140	160	13	TRB001400	●	
140	190	15	TRB301400	●	
145	165	13	TRB001450	●	
145	170	13	TRB101450	●	
145	180	15	TRB301450	●	
148	170	15	TRB001480	●	
150	180	15	TRBA01500		○
160	180	15	TRB001600	●	
160	190	13	TRB001600	●	●
165.10 (6.50")	193.88 (7.63")	15.75 (0.62")	TRB001651	●	
174.60 (6.87")	200.23 (7.88")	15.90 (0.63")	TRB001746	●	
180	210	15	TRBA01800	●	
180	220	16	TRB001800	●	
190	220	15	TRBA01900	○	
210	240	15	TRBA02100		○
220	250	15	TRB002200	●	
230	260	15	TRBA02300	○	
240	270	15	TRBA02400	●	●
250	280	15	TRBA02500	●	

● In one of the preferred materials

○ In other commercial materials

Values in brackets are inch sizes.



Dimension			TSS Part No.	Material	
d <sub>1</sub>	d <sub>2</sub>	b		NBR	FKM
260	290	16	TRB002600	○	●
270	310	16	TRB102700		○
280	310	16	TRB002800	○	
280	320	20	TRBA02800	○	
290	330	18	TRB202900	○	
300	332	16	TRB003000	●	
300	340	20	TRBA03000	○	○
310	350	18	TRB003100	●	
320	360	18	TRB103200	●	
325	365	16	TRBA03250	●	
330	370	18	TRB003300	○	
340	372	16	TRB003400	○	
340	380	20	TRBA03400	●	●
360	400	18	TRB003600	●	
360	400	20	TRBA03600		●
374.65 (14.75")	419.00 (16.50")	22.20 (0.87")	TRB003746	●	
380	420	20	TRBA03800	●	
390	430	18	TRB003900	○	○
400	440	20	TRBA04000	○	○
440	470	20	TRB004400	○	
460	500	20	TRBA04600	●	
467	510	20	TRB004670	●	
490	530	20	TRB004900	○	
500	540	20	TRBA05000	○	
500	540	20	TRBA05000		○
500	550	22	TRB005000	○	
530	570	20	TRB005300	○	
560	610	20	TRB005600		○
560	610	20	TRB005600	○	
580	620	20	TRB105800	○	
600	640	20	TRB006000	○	○
600	640	20	TRB006000	○	
620	660	20	TRB006200	○	
650	690	25	TRB206500	○	
700	750	25	TRB007000	○	
700	764	25	TRB107000	○	
720	780	25	TRB207200		○
740	780	20	TRB107400		○
760	800	20	TRB107600		○
960	1,000	20	TRB009600	○	
1,120	1,170	20	TRB011200		○
1,120	1,170	20	TRB011200		○

● In one of the preferred materials

○ In other commercial materials

Values in brackets are inch sizes.



## ■ Type TRF

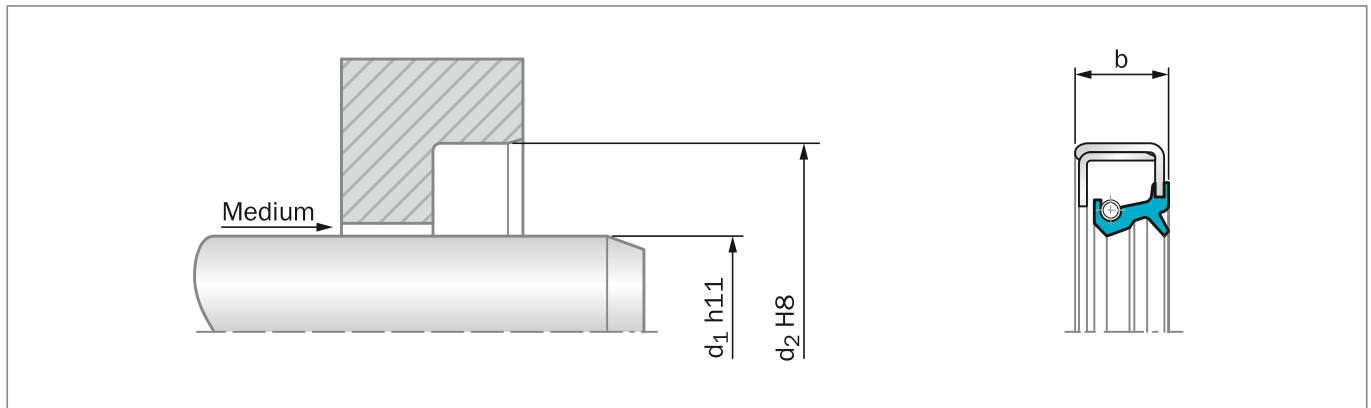

Figure 19: Installation Drawing

### GENERAL DESCRIPTION

Trelleborg Sealing Solutions Type TRF are reinforced metal cased radial lip seals with dust lip. The supplementary metal inner ring provides a superior stiffness. This type is recommended for use in heavily polluted environments. To achieve a long lifetime a suitable lubricant between the two sealing lips should be applied. As the static sealing between housing and metallic shell is limited, low viscosity media can "creep". Better performance can be achieved with epoxy based resin O.D. coating. This special treatment is on request.

### ADVANTAGES

- Superior radial stiffness, especially for very large diameters
- Very good fitting stability avoiding pop-out of the seal
- Modern lip design provides low radial forces
- Cost effective
- Suitable for use in combination with axial seal (V-Ring and GAMMA-seal)

### APPLICATION EXAMPLES

- Transmission systems (e.g. gearboxes)
- Pumps
- Electrical motors
- Machine tools
- Heavy engineering applications (e.g. mills in steel industry)

### OPERATING CONDITIONS

<b>Pressure:</b>	Up to 0.05 MPa
<b>Temperature:</b>	-40 °C to +200 °C (depending on material)
<b>Speed:</b>	Up to 10 m/s (depending on material)
<b>Media:</b>	Mineral and synthetic lubricants (CLP, HLP, APGL etc.)

Trelleborg Sealing Solutions has carried out several thousand compatibility tests. Please ask your local Trelleborg Sealing Solutions marketing company for details.

### IMPORTANT NOTE

The above data are maximum values and cannot be used at the same time, e.g. the maximum operating speed depends on material type, pressure and temperature.



**Table 16: Materials**

TSS Compound Reference	Standard Compound	Temperature °C	Standard Metal insert	Standard spring
N7MMR	NBR (70 Shore A)	-30 °C - 100 °C	Carbon steel	Carbon steel
4N011/4NV11	NBR (75 Shore A)	-30 °C - 100 °C	Carbon steel	Carbon steel
VCBVR	FKM (70 Shore A)	-20 °C - 200 °C	Carbon steel	Stainless steel
4V012	FKM (75 Shore A)	-20 °C - 200 °C	Carbon steel	Stainless steel

Special grades and other materials (ACM, EACM, EPDM, HNBR, VMQ) on request.  
Metal insert, and spring, can be supplied in different materials on request.

**ORDERING EXAMPLE OIL SEAL TSS TYPE**

<b>TSS Type:</b>	F
<b>Code:</b>	TRF
<b>Dimensions:</b>	Shaft diameter 110 mm Housing diameter 140 mm Width 13 mm
<b>Material:</b>	NBR
<b>Material Code:</b>	N7MMR

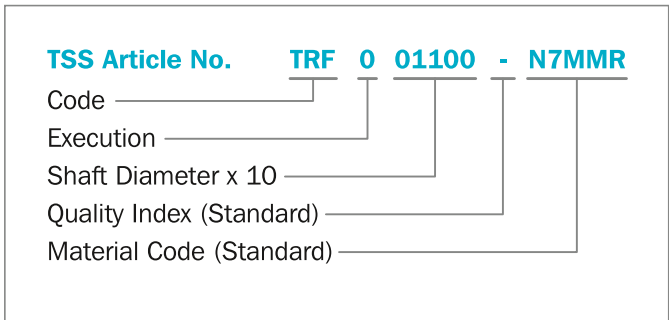

**Table 17: Preferred Series / Dimension, TSS Part Numbers**

Dimension			TSS Part No.	Material	
d <sub>1</sub>	d <sub>2</sub>	b		NBR	FKM
35	52	9	TRF000350	●	
40	55	9	TRF000400	●	
41	53	7	TRF000410	●	
50	65	10	TRF300500	●	
50	80	10	TRF100500	●	
60	80	8	TRFB00600	●	
90	130	13	TRF100900	●	
100	130	13	TRF101000		○
105	140	13	TRF001050		●
110	140	13	TRF001100	●	●
115	140	11	TRF001150	●	
120	140	13	TRF001200		●
125	150	12	TRFA01250		●
130	155	10	TRF001300	●	
130	170	15	TRF101300	●	
132	160	13	TRF001320	●	
140	170	15	TRFA01400	●	
148	170	14.5	TRF101480	●	●
148	170	15	TRF001480	●	
150	180	15	TRFA01500	●	
170	200	15	TRFA01700	●	
200	225	15	TRF102000	○	
240	270	15	TRFA02400	○	●

Dimension			TSS Part No.	Material	
d <sub>1</sub>	d <sub>2</sub>	b		NBR	FKM
240	280	16	TRF002400	●	
265	290	16	TRF002650		○
275	310	16	TRF102750		○
380	420	20	TRF003800	●	●
467	510	20	TRF004670	○	
920	970	20	TRF009200		○

- In one of the preferred materials
- In other commercial materials



## ■ Non-standard Radial Oil Seals

When standard seals in accordance with DIN 3760/3761 (Table 3) can not fulfill the technical requirements of the application, special seals are required.

Special seals are used for high speed, medium- or high-pressure or heavy duty applications, for example.

If a standard or special seal design will be used, the media compatibility with the compound needs to be given (see Figure 13).

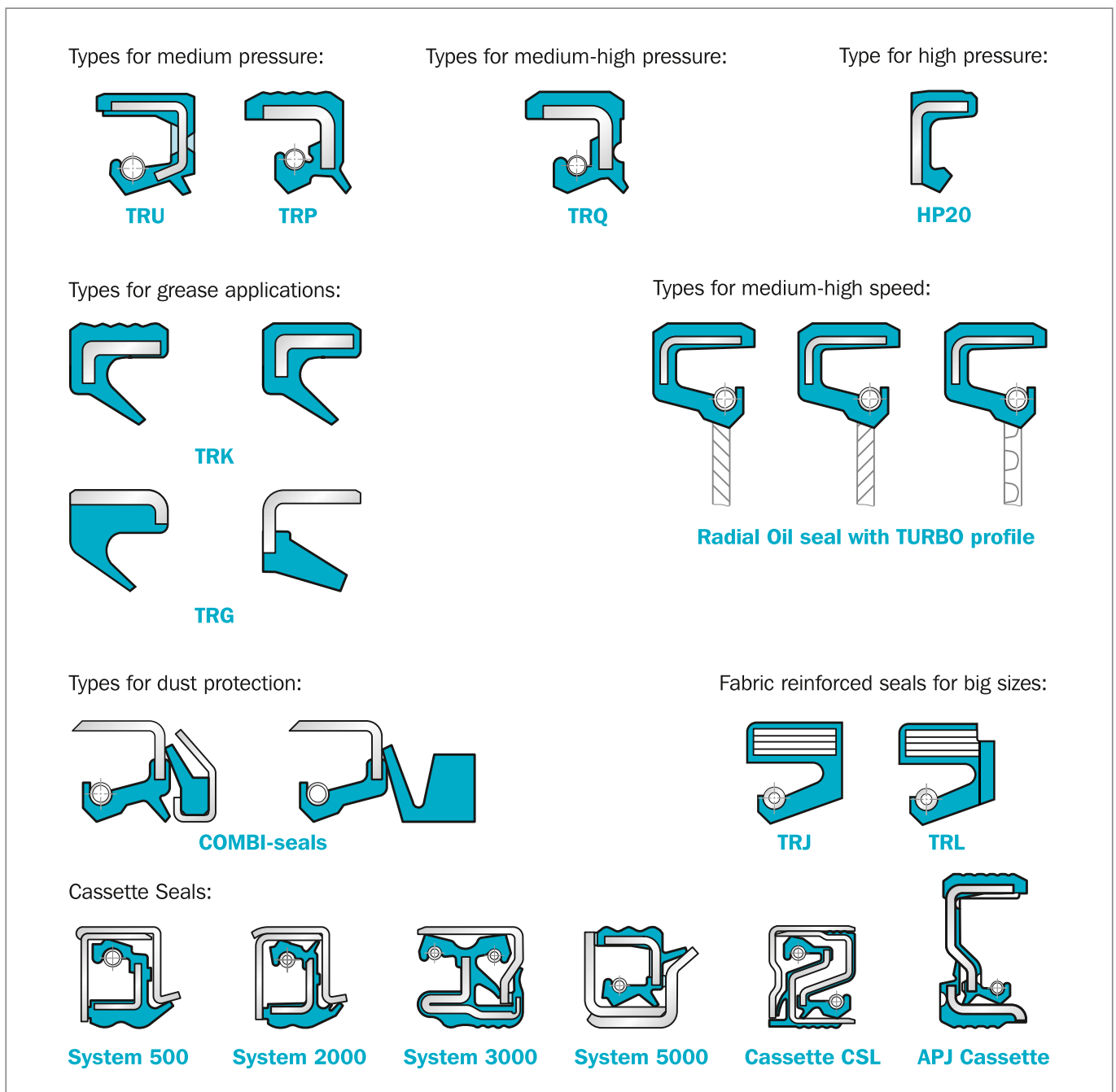

Figure 20: Selection of special radial seals



## ■ Type TRU – Medium Pressure Oil Seal

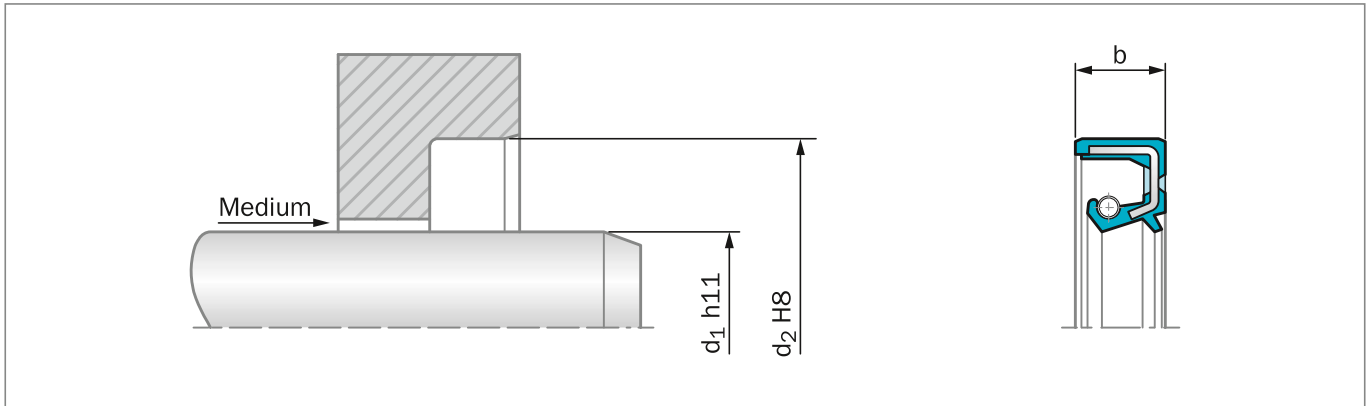

Figure 21: Installation Drawing

### GENERAL DESCRIPTION

Trelleborg Sealing Solutions Type TRU is a seal with a completely rubber covered outer diameter. This type of seal is designed with an extended metallic support of the diaphragm that allows pressures up to 0.5 MPa. In order to avoid "pop-out" of the seal, we suggest to fit an axial retainer (e.g. circlip, shoulder, etc.). The additional dust lip protects the main sealing lip against dust and other fine solid contaminants and therefore this type is recommended for use in polluted environments. To achieve a long lifetime, a suitable lubricant between the two sealing lips should be applied.

### ADVANTAGES

- Good static sealing
- Compensation of different thermal expansion
- Reduced risk of fretting corrosion
- Up to 0.5 MPa pressure at moderate peripheral speed
- Effective protection against air side contaminants
- No need for Back-up Ring

### APPLICATION EXAMPLES

- Transmission systems (e.g. gearboxes)
- Pumps
- Hydraulic motors
- Machinery industry

### OPERATING CONDITIONS

<b>Pressure:</b>	Up to 0.5 MPa
<b>Temperature:</b>	-40 °C to +200 °C (depending on material)
<b>Speed:</b>	Up to 10 m/s (depending on material)
<b>Media:</b>	Mineral and synthetic lubricants (CLP, HLP, APGL etc.)

Trelleborg Sealing Solutions has carried out several thousands compatibility tests. Please ask your local Trelleborg Sealing Solutions marketing company for details.

### IMPORTANT NOTE

The above data are maximum values and cannot be used at the same time, e.g. the maximum operating speed depends on material type, pressure and temperature.



Table 18: Materials

TSS Material code	Standard Material*	Standard Metal Insert**	Standard Spring**
N7MMR	NBR (70 Shore A)	Carbon steel	Carbon steel
VCBVR	FKM (70 Shore A)	Carbon steel	Stainless steel

\* Special grades and other materials (ACM, EACM, EPDM, HNBR, VMQ) on request.

\*\* Metal insert and spring, can be supplied in different materials on request.

## ORDERING EXAMPLE OIL SEAL TSS TYPE

<b>TSS Type:</b>	U	
<b>Code:</b>	TRU	
<b>Dimensions:</b>	Shaft diameter	40 mm
	Housing diameter	52 mm
	Width	7 mm
<b>Material:</b>	NBR	
<b>Material Code:</b>	N7MMR	

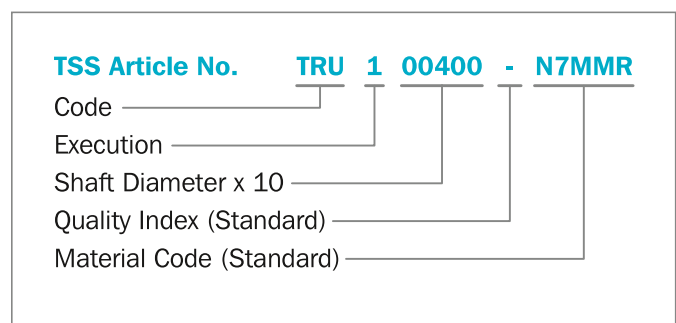

Table 19: Preferred Series / Dimension, TSS Part Numbers

Dimension			TSS Part No.	Material	
d <sub>1</sub>	d <sub>2</sub>	b		NBR	FKM
8	16	6	TRU100080	●	
8	22	7	TRU000080	●	●
10	22	6	TRU000100	●	
12	22	6	TRU200120	●	
12	22	7	TRU000120	●	
15	25	6	TRU100150	●	
15	30	7	TRU000150	●	
16	28	6	TRU000160		●
20	35	6	TRU300200	●	
20	40	6	TRU000200	●	
22	32	7	TRU100220	●	●
22	42	7	TRU200220	●	
22	47	7	TRU000220		●
23	40	6	TRU000230	●	●
25	37	6	TRU100250	●	
25	40	7	TRU000250	●	●
27	42	7	TRU100270	●	
28	40	6	TRU000280		●
28	41	6	TRU200280		●
28	47	7	TRU100280		●
29	40	6	TRU000290	●	
30	42	6	TRU000300	●	●
32	47	6	TRU000320		●
35	47	7	TRU000350		●

Dimension			TSS Part No.	Material	
d <sub>1</sub>	d <sub>2</sub>	b		NBR	FKM
35	50	7.5	TRU300350	●	
35	52	6	TRU100350		●
38	62	12	TRU000380	●	
40	55	8	TRU200400	●	●
40	62	6	TRU400400	●	●
42	56	5.5	TRU100420		●
45	62	7	TRU000450		●
45	65	8	TRU100450	●	
45	72	8	TRUD00450	●	
46	60	6	TRU000460	●	●
47	62	7	TRU000470	●	
50	65	7	TRU200500		●
50	65	8	TRU200500	●	
50	68	8	TRU000500	●	
55	72	7	TRU000550	●	●
55	72	8	TRU200550	●	
55	75	7	TRU100550		●
60	75	8	TRU100600		●
60	80	7	TRU000600	●	●
65	85	10	TRU000650	●	
70	90	7	TRU100700	●	●
80	100	7	TRU000800	●	

● In one of the preferred materials  
○ In other commercial materials



Dimension			TSS Part No.	Material	
d <sub>1</sub>	d <sub>2</sub>	b		NBR	FKM
90	110	7.5	<a href="#">TRU000900</a>		●
90	110	13	<a href="#">TRU200900</a>		●
90	125	12	<a href="#">TRU100900</a>	●	
95	120	12	<a href="#">TRU000950</a>	●	
100	120	12	<a href="#">TRUA01000</a>	●	
120	150	12	<a href="#">TRU101200</a>	●	
135	165	15	<a href="#">TRU001350</a>	●	
140	160	10	<a href="#">TRU201400</a>	●	●
140	170	12	<a href="#">TRU001400</a>	●	
160	185	8.5	<a href="#">TRU101600</a>	●	
160	190	15	<a href="#">TRU001600</a>	●	
200	230	15	<a href="#">TRU002000</a>	●	

- In one of the preferred materials
- In other commercial materials





## ■ Type TRP – Medium Pressure Oil Seal

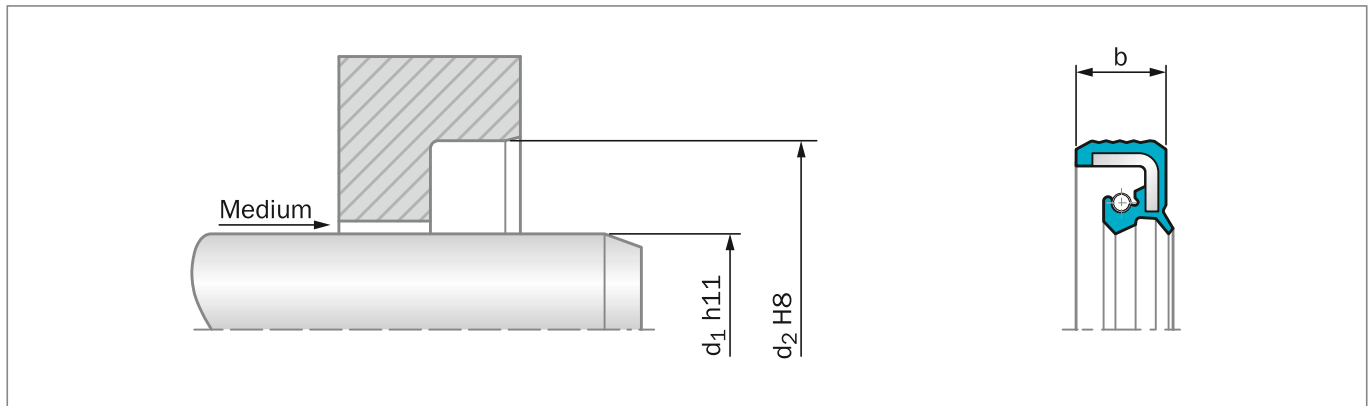

Figure 22: Installation Drawing

### GENERAL DESCRIPTION

Trelleborg Sealing Solutions type TRP are seals with a completely rubber covered outer diameter. This type of seal is designed for pressures up to 0.5 MPa. In order to avoid "pop-out" of the seal, we suggest to fit an axial retainer (e.g. circlip, shoulder, etc.) The additional dust lip protects the main sealing lip against dust and other fine solid contaminants and therefore this type is recommended for use in polluted environments. To achieve a long lifetime, a suitable lubricant between the two sealing lips should be applied. The OD can be provided flat or waved.

### ADVANTAGES

- Good static sealing
- Compensation of different thermal expansion
- Reduced risk of fretting corrosion
- Up to 0.5 MPa pressure at moderate peripheral speed
- Low lip and shaft wear at low pressure run
- Effective protection against air side contaminants
- No need for Back-up Ring

### APPLICATION EXAMPLES

- Transmission systems (e.g. gearboxes)
- Pumps
- Hydraulic motors
- Machinery industry

### OPERATING CONDITIONS

<b>Pressure:</b>	Up to 0.5 MPa
<b>Temperature:</b>	-40 °C to +200 °C (depending on material)
<b>Speed:</b>	Up to 10 m/s (depending on material)
<b>Media:</b>	Mineral and synthetic lubricants (CLP, HLP, APGL etc.)

Trelleborg Sealing Solutions has carried out several thousands compatibility tests. Please ask your local Trelleborg Sealing Solutions marketing company for details.

### IMPORTANT NOTE

The above data are maximum values and cannot be used at the same time, e.g. the maximum operating speed depends on material type, pressure and temperature.



**Table 20: Materials**

TSS Compound Reference	Standard Compound	Temperature °C	Standard Metal insert	Standard spring
N7MMR	NBR (70 Shore A)	-30 °C - 100 °C	Carbon steel	Carbon steel
4N011/4NV11	NBR (75 Shore A)	-30 °C - 100 °C	Carbon steel	Carbon steel
VCBVR	FKM (70 Shore A)	-20 °C - 200 °C	Carbon steel	Stainless steel
4V012	FKM (75 Shore A)	-20 °C - 200 °C	Carbon steel	Stainless steel

Special grades and other materials (ACM, EACM, EPDM, HNBR, VMQ) on request.  
Metal insert and spring, can be supplied in different materials on request.

**ORDERING EXAMPLE OIL SEAL TSS TYPE**

<b>TSS Type:</b>	P	
<b>Code:</b>	TRP	
<b>Dimensions:</b>	Shaft diameter	50 mm
	Housing diameter	72 mm
	Width	7 mm
<b>Material:</b>	NBR	
<b>Material Code:</b>	N7MMR	

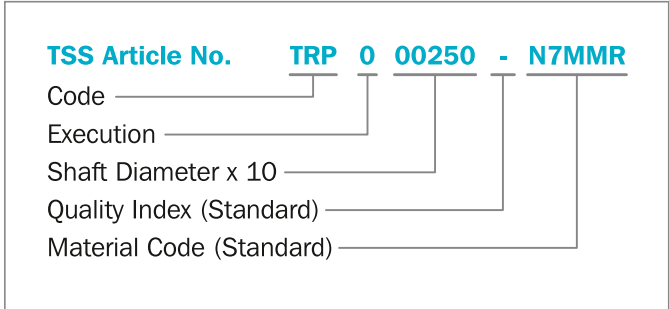

**Table 21: Preferred Series / Dimension, TSS Part Numbers**

Dimension			TSS Part No.	Material	
d <sub>1</sub>	d <sub>2</sub>	b		NBR	FKM
8	22	6	TRP000080	●	
10	22	7	TRP000100	●	
10	27	7	TRP100100		●
11	19	6	TRP000110	●	
12	22	6	TRP000120	●	●
13	22	5	TRP000130		●
16	26	7	TRP000160	●	
17	30	7/7.9	TRP000170		●
18	30	7	TRP000180		●
18	35	7	TRPC00180		●
19	27	5	TRP000190	●	
19	32	5	TRP200190	●	
19.5	30	6	TRP000195	●	●
21.5	30	6	TRP000215	●	●
21.5	33	6	TRP100215		●
20	35	6	TRP100200		●
20	40	7	TRP000200		●
22	32	6	TRP100220		●
22	35	6	TRP200220	●	
22	40	6	TRP000220		●
25	35	6	TRP100250	●	●
25	40	7	TRP000250	●	●
28	40	6	TRP000280		●
28	40	9	TRP100280	●	
30	42	6	TRP000300	●	

Dimension			TSS Part No.	Material	
d <sub>1</sub>	d <sub>2</sub>	b		NBR	FKM
33	45	5	TRP000330	●	●
35	47	6	TRP100350	●	
35	52	6	TRP000350	●	●
35	52	7	TRP000350	●	
36	48	5.5	TRP000360	●	
40	55	7	TRPB00400	●	●
40	62	6	TRP100400	●	●
40	67	7	TRP000400		●
45	62	7	TRP000450	●	
50	72	7	TRP000500	●	●
55	70	7	TRP000550	●	●
60	80	7	TRP000600	●	●
70	90	7	TRP000700	●	●
80	100	7/8	TRP000800	●	●
85	105	7.5	TRP000850	●	
85	110	8	TRP100850		●
90	110	7.5	TRP000900		●
95	120	12	TRP000950	●	
100	120	7.5	TRP001000		●
105	130	7.5	TRP101050		●
124	139	8	TRP001240		●
190	220	12	TRP001900	●	

● In one of the preferred materials  
○ In other commercial materials



## ■ Type TRQ – Medium-high Pressure Oil Seal

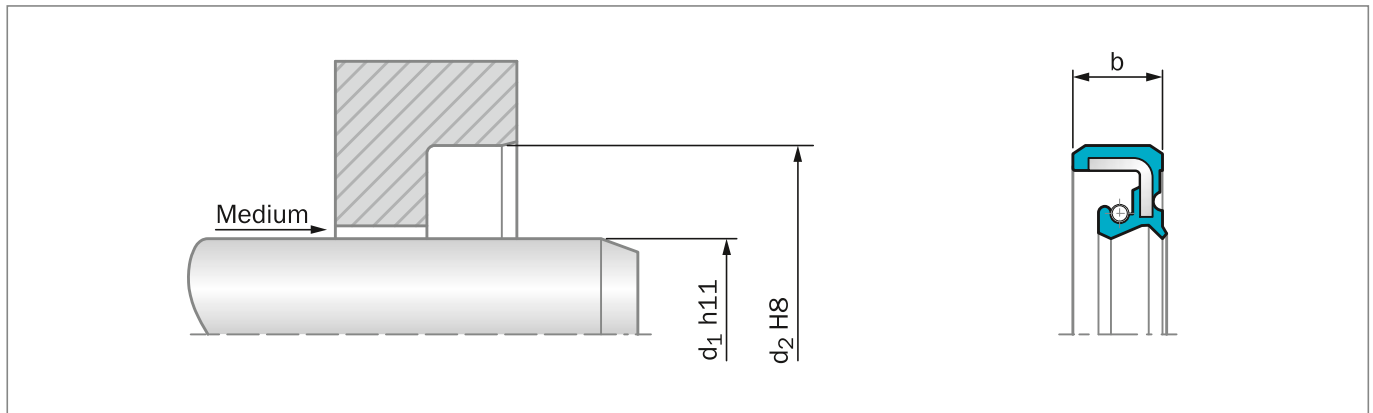

Figure 23: Installation Drawing

### GENERAL DESCRIPTION

STEFA Type 12 CC (TRQ\_D) is a seal with a completely rubber covered outer diameter. This type of seal is designed for pressures up to 1 MPa. In order to avoid "pop-out" of the seal, we suggest to fit an axial retainer (e.g. circlip, shoulder, etc.). The additional dust lip protects the main sealing lip against dust and other fine solid contaminants and therefore this type is recommended for use in polluted environments. To achieve a long lifetime, a suitable lubricant between the two sealing lips should be applied. The OD can be provided flat or waved.

### ADVANTAGES

- Good static sealing
- Compensation of different thermal expansion
- Reduced risk of fretting corrosion
- Up to 1 MPa pressure at low peripheral speed
- Effective protection against air side contaminants
- No need of Back-up Ring.

### APPLICATION EXAMPLES

- Transmission systems (e.g. gearboxes)
- Pumps
- Hydraulic motors
- Machinery industry

### OPERATING CONDITIONS

<b>Pressure:</b>	Up to 1 MPa
<b>Temperature:</b>	-40 °C to +200 °C (depending on pressure and material)
<b>Speed:</b>	Up to 5 m/s (depending on material)
<b>Media:</b>	Mineral and synthetic lubricants (CLP, HLP, APGL etc.)

Trelleborg Sealing Solutions has carried out several thousands compatibility tests. Please ask your local Trelleborg Sealing Solutions marketing company for details.

### IMPORTANT NOTE

The above data are maximum values and cannot be used at the same time, e.g. the maximum operating speed depends on material type, pressure and temperature.



**Table 22: Materials**

TSS Material Code	Standard Material*	Standard Metal Insert**	Standard Spring**
4N011	NBR (75 Shore A)	Carbon steel	Carbon steel
4V012	FKM (75 Shore A)	Carbon steel	Stainless steel

\* Special grades and other materials (ACM, EACM, EPDM, HNBR, VMQ) on request.

\*\* Metal insert and spring, can be supplied in different materials on request.

**ORDERING EXAMPLE OIL SEAL STEFA TYPE**

<b>STEFA Type:</b>	12CC	
<b>Code:</b>	TRQ_D	
<b>Dimensions:</b>	Shaft diameter	24 mm
	Housing diameter	40 mm
	Width	6 mm
<b>Material:</b>	NBR 1452	
<b>Material Code:</b>	4N011	

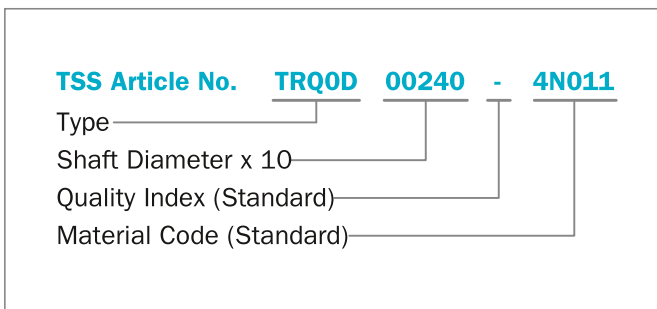

**Table 23: Preferred Series / Dimension, TSS Part Numbers**

Dimension			TSS Part No.	Material	
d <sub>1</sub>	d <sub>2</sub>	b		NBR	FKM
24	40	6	TRQ0D0240	●	
27	44	7	TRQ0D0270	●	●
32	47	6	TRQ0D0320		●
40	55	7	TRQBD0400		●
40	62	5.5	TRQ0D0400	●	
40	62	6	TRQ1D0400	●	
50	72	6.5	TRQ1D0500	●	
50	72	7	TRQ0D0500		●
60	80	7	TRQ0D0600		●
60	80	6.5	TRQ1D0600	●	
60	80	8	TRQ2D0600	●	
70	90	7	TRQ0D0700		●
130	160	11	TRQ0D1300	●	●

● In one of the preferred materials

○ In other commercial materials



## ■ Type HP20 – High Pressure Oil Seal

### GENERAL DESCRIPTION

HP20 is a patented Radial Oil Seal providing an optimal sealing solution for hydraulic devices with rotating shafts and working pressures up to 20 MPa.

### APPLICATION EXAMPLES

- Hydraulic drive motors
- Material handling
- Forestry and agriculture machinery
- Construction machinery
- Turf care
- Scissor lifts
- Winches

### SPECIAL FEATURES

Lip extrusion prevented at high pressures, due to a metal retainer bonded to the elastomeric lip, while a patented pressure-balancing sealing lip design provides stable contact for the sealing lip on the shaft. Heat dissipation is improved through contact between the metal retainer and the housing plate

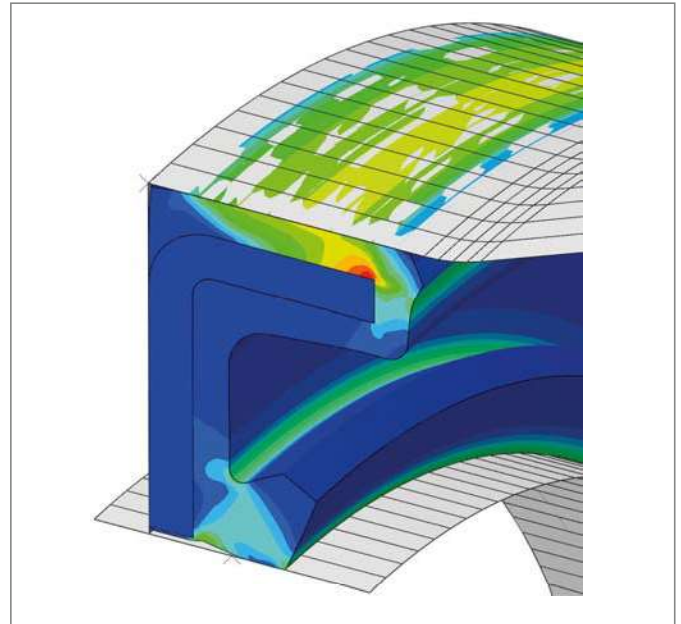

Figure 24: FEA at high pressure

### MATERIALS AND OIL COMPATIBILITY

HP20 is composed of a metal retainer and an elastomeric sealing lip. The sealing lip is made from Trelleborg proprietary elastomers, specifically developed for working in high pressure hydraulic oil; standard available grades are Hydrogenated-Nitrile HNBR, Fluoroelastomer FKM, and high grade Fluoroelastomer FKM XploR; other special elastomer compounds can be used according to customer specifications.

The HNBR version operates with mineral oils according to DIN 51524-2 cat. HLP or ISO 11158 cat. HM (ISO 6743/4 cat. L-HM) or ISO VG46 – BDS ISO 3448, purity class 16/13 – ISO 4406 -1999.

FKM versions are also applicable with bio-degradable hydraulic oils (compatibility testing is recommended).



### WORKING CONDITIONS

#### Speed and pressure working conditions

The main factors affecting the performance of HP20 seals are the pressure and speed combination, the oil type, temperature and flow amount.

The rated pressure vs. shaft speed working conditions are given in Figure 25.

Several tests have been performed to define this curve using hydraulic mineral oil ISO VG46 at +60 °C, an oil flow above 2 liters per minute, and an STBM eccentricity below 0.1 mm. The real performance of HP20 seals in the field is affected by other parameters that are not possible to reproduce in the laboratory, such as shaft acceleration, the thermal conductivity

of the shaft and bore, oil contamination, system vibration and pressure transients in the oil. Trelleborg Sealing Solutions recommends customer testing on the device in the normal and worst case scenarios, to validate its functionality.

Trelleborg Sealing Solutions is available to evaluate special working conditions and suggest the best configuration of HP20 seals in terms of compound, metal retainer and sealing lip shape.

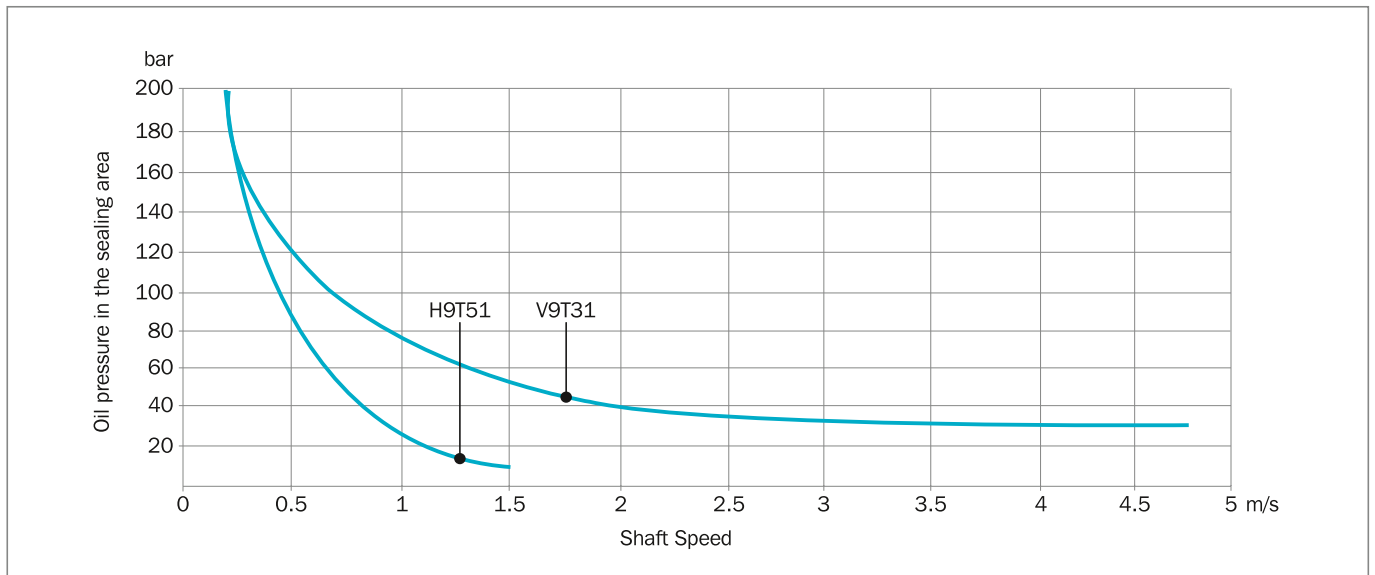

Figure 25: HP20 Rated Working Conditions for H9T51 and V9T31 Materials

#### Working eccentricity

HP20 seals, in order to work properly, requires the value of Shaft To Bore Misalignment (STBM) to be kept below the threshold given in the graph.

The STBM needs to be obtained through a proper tolerance study on the motor design, proper machining and installation, and appropriate bearings capable of supporting axial loads on the shaft and wear due to age.

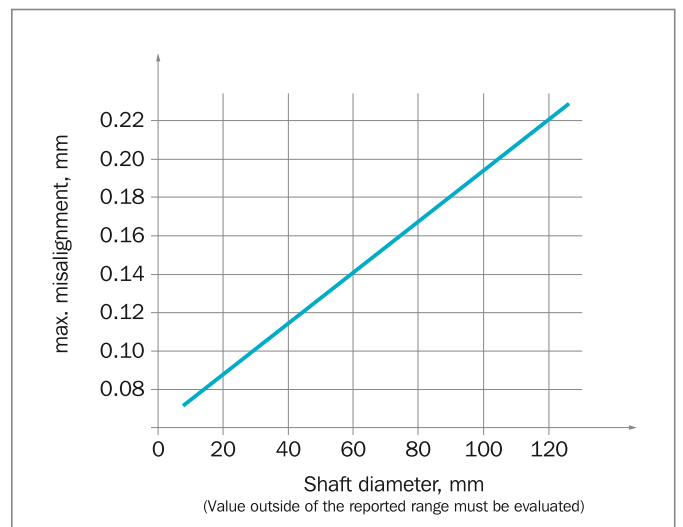

Figure 26: Shaft to bore misalignment



## HOUSING AND SHAFT DESIGN

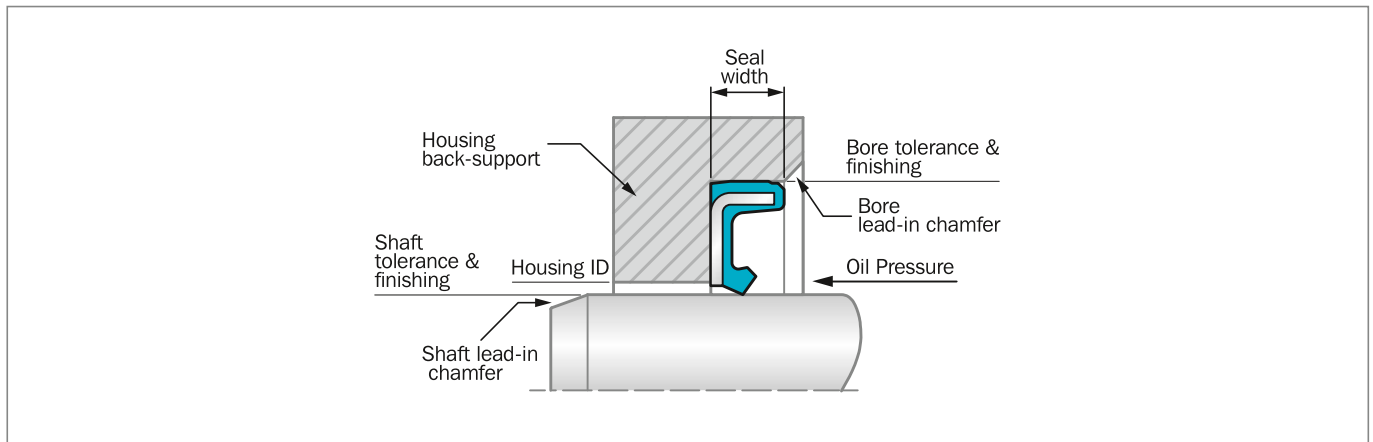

Figure 27: Installation Drawing

### Shaft materials

HP 20 seal are for use with shafts manufactured from mild steel or stainless steel.

### Shaft hardness

Required hardness is Rockwell-C 55; recommended 60 HRC.

### Shaft finish

Required roughness is between 0.2 and 0.5 micrometers Ra with no machine lead. The most accepted method of obtaining this finish is plunge grinding.

### Shaft geometry

HP20 seals are designed to work with shaft tolerance h11. Shaft chamfer must be aligned with the values given in Table 24 and Table 25 and sharp edges radiused to avoid damaging sealing lips during installation.

The shaft surfaces over which the seal lip slides during installation should be kept smooth and free from any burrs or rough patches.

**Table 24: Shaft lead-in chamfers**

Ø Shaft mm	Shaft Chamfer Length mm	Shaft Chamfer Angle deg
16 - 30	2.00 (±0.10)	20°
30 - 40	2.20 (±0.10)	20°
40 - 50	2.50 (±0.10)	20°
50 - 70	3.20 (±0.10)	20°
70 - 120	4.50 (±0.12)	20°

### Housing materials

HP20 benefits from being installed in a highly thermally conductive material housing.

### Bore finishing

A finish of 2.5 micrometers Ra or better is recommended.

### Bore geometry

- Bore tolerance is H8
- Bore lead-in chamfer according to Table 25
- Housing must be provided with back-support for the HP20 seal to retain the pressure force and dissipate heat from the back face of the HP20 seal; the back support must have the same ID as the HP20 metal retainer

### Shaft to bore misalignment

- The maximum assembly and working misalignment must be according to Figure 26

**Table 25: Bore lead-in chamfers**

Ø Shaft mm	Seal Width mm	Bore Chamfer Length mm	Bore Chamfer Angle deg
16 - 30	4.2 - 5.5 (±0.20)	1.00	15°
30 - 40	4.5 - 6.5 (±0.20)	1.20	15°
40 - 50	5.5 - 7.0 (±0.20)	1.30	15°
50 - 70	6.0 - 7.5 (±0.25)	1.50	15°
70 - 120	7.5 - 9.5 (±0.30)	1.70	15°



## INSTALLATION

HP20 seals are usually first assembled on the metal housing, and then the shaft is fitted inside the seal from the air side or from the oil side depending on device and bearing positioning.

During assembly operation, it's necessary to apply a good layer of grease to both the sealing lip and shaft, in order to:

- provide smooth sliding of the lip on the shaft during assembly
- provide pre-lubrication during the first turns of the shaft

The type of grease recommended for this operation is an LS-EP2 grease.

It's very important to align the cover and the shaft with a precentering system to avoid stress on the sealing lip. While fitting the shaft inside the seal, gently rotate the shaft in order to reduce to assembly tension created during the installation process.

Never install a seal over splines or keyways without using a special installation tool that protects the seal lip from contact with sharp edges.

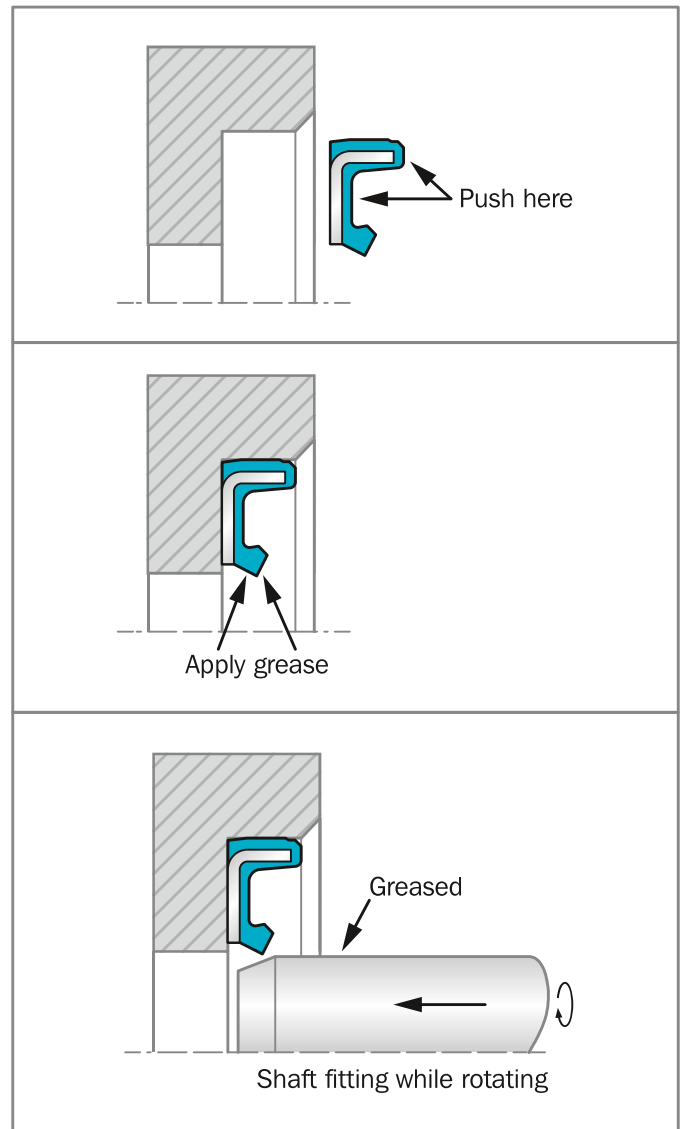

Figure 28: Installation Instructions



**Table 26: Materials**

TSS Compound	Rated hydraulic oil viscosity	Minimum working environment temperature	Maximum working oil temperature	Chemical compatibility with hydraulic oils
<b>H9T51</b> Low temperature HNBR	46 cSt	-30° C / -22° C	+80° C / +176° F	Mineral oils
<b>V9T31</b> FKM XploR	46 cSt	-30° C / -22° C	+120° C / +248° F	Mineral oils, synthetic oils, bio-degradable oils

**Table 27: Preferred Series / Dimension, TSS Part Numbers**

Dimension			TSS Part No.	Material	
d <sub>1</sub>	d <sub>2</sub>	b		H9T51	V9T31
16.9	28	5.35	TRT0A0169	●	●
28.56	38	4.72	TRT1A0286	●	●
28.56	42	4.72	TRT0A0286	●	●
31.75	41.28	5.00	TRT0A0318		●
35	48	4.72	TRT0A0350	●	●
38.1	50	4.29	TRT0A0381	●	●
45	65	4.45	TRT0A0450	●	●
50	70	5.08	TRT0A0500	●	●
60	80	5.97	TRT0A0600	●	●
72	95	7.00	TRT0A0720	●	

Please contact your local Trelleborg Sealing Solutions marketing company for sizes and materials not listed above.

### ORDERING EXAMPLES OF HP20 SEALS

<b>ROS Type:</b>	HP20	
<b>Design Code:</b>	TRT	
<b>Dimensions:</b>	Shaft diameter	35 mm
	Housing diameter	48 mm
	Width	4.72 mm
<b>Size Code:</b>	TRT0A0350	
<b>Elastomer:</b>	H9T51	
<b>Material Code:</b>	4HH1	

<b>ROS Type:</b>	HP20	
<b>Design Code:</b>	TRT	
<b>Dimensions:</b>	Shaft diameter	28.56 mm
	Housing diameter	42 mm
	Width	4.72 mm
<b>Size Code:</b>	TRT0A0286	
<b>Elastomer:</b>	V9T31	
<b>Material Code:</b>	4VT4	

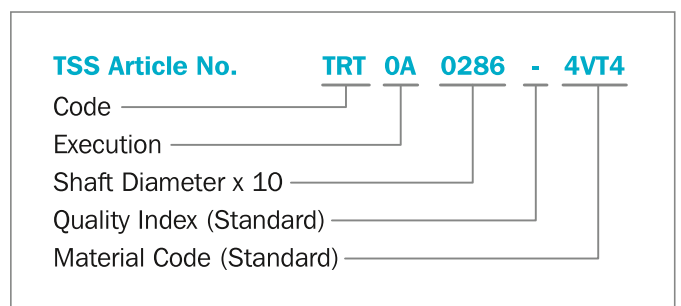
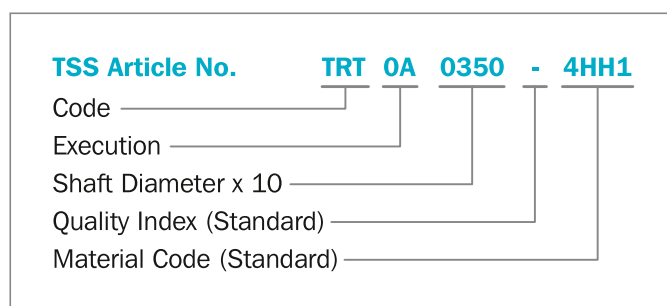



## ■ HiSpin® HS40

### GENERAL DESCRIPTION

HiSpin® HS40 offers e-Mobility and high speed electric motor manufacturers a long life and energy saving bi-directional rotary seal. It consists of a flexible lip made from proprietary, high-performance XLT fluoroelastomer material and supported by a metal core to provide cost-effective performance and reliability. A compact footprint reduces the amount of installation space required and its back-pumping feature further reduces friction and improves sealing performance.

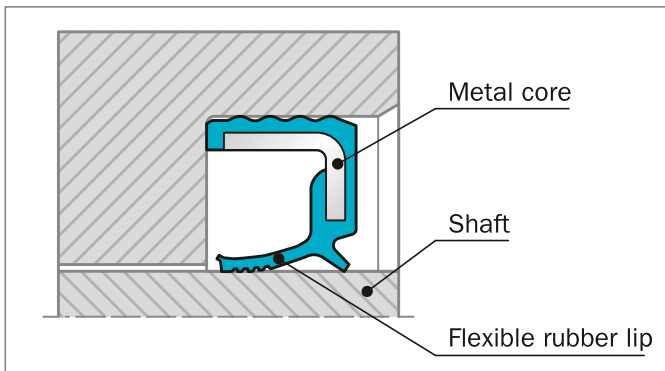

Figure 29: HiSpin® HS40

### METHOD OF OPERATION

Developers are continuously improving the effectiveness of the electric drive unit; a combined electric motor and gearbox in a shared housing.

The drive unit is the main cost-driver of future electric vehicle development and offers new challenges for automotive manufacturers. While the gearbox requires efficient lubrication, it is essential that the motor remains dry. Therefore, a highly reliable seal is required between the two parts.

Providing outstanding low friction capabilities, HiSpin® HS40 meets the demanding conditions of automotive high-speed electric motors. A unique hydrodynamic feature helps reduce frictional torque, while oil back-pumping leads to improved sealing performance without causing any shaft damage.

Our proprietary XLT high-performance fluoroelastomer (FKM) elastomer range provides outstanding resistance to extreme engine conditions resulting from high motor speeds and aggressive synthetic ATF fluids. Testing of the new generation XLT compounds has proven that these low temperature FKM grades outperform and extend the temperature performance capability of traditional FKM elastomers.

### ADVANTAGES

- High speed operation (up to 40 m/s)
- Bi-directional sealing capability
- Compact design to reduce assembly space
- Wide temperature range, from -45 °C to +200 °C
- Can handle run-out of up to 0.1 mm
- Excellent sealing performance in different lubricated environments
- Adds value with low frictional torque
- Reduces heat development
- Proven compatibility with various e-Mobility transmission fluids
- Negligible shaft wear
- Easy installation
- Cost-effective
- Available in different outer diameter configurations, e.g. partially rubber covered and air vents on the outer diameter
- Available in other materials, such as ACM
- Provide in accordance with IATF 16949

### APPLICATION EXAMPLES

HiSpin® HS40 provides optimal sealing in:

- Electric drive units for e-Mobility applications
- High speed electric drive units
- Automotive transmissions
- Servo-motors
- Pumps

### OPERATING CONDITIONS

Seal performance is influenced by such factors as lubrication capability of the sealed media and heat dissipation in the hardware, it follows that testing should always be performed. With good lubrication, the following values can be assumed as a guideline:

<b>Pressure:</b>	0.5 bar
<b>Temperature:</b>	-45 °C to +200 °C
<b>Speed:</b>	Up to 40 m/s
<b>PV:</b>	dependent upon design and application
<b>Acceleration:</b>	dependent upon design and application
<b>Media:</b>	Commonly specified fluids for e-Mobility & transmission applications



### MATING SURFACE MATERIALS

Sealing of applications with rotating movements requires very good mating surfaces. A minimum hardness of 55 HRC to a hardening depth of at least 0.5 mm is recommended.

<b>Ra:</b>	0.1 - 0.2 $\mu\text{m}$
<b>Rz:</b>	1.0 $\mu\text{m}$
<b>Bearing ratio (Tp (Mr)):</b>	(50 - 70% @ depth of p = 0.25 Rz (Rtm); relative to a ref. line c: 5% tp)
<b>Mating surface hardness:</b>	min. 55 HRC

### IMPORTANT NOTE

Housing design and correct installation are important for the performance of the HiSpin<sup>®</sup> HS40. Information on shaft and housing design with installation guides are available from your local Trelleborg Sealing Solutions marketing company.

### AGING AND TORQUE

To prove the performance and longevity of HiSpin<sup>®</sup> HS40, testing using real-world speeds and media likely to be encountered during operation has been undertaken. Test conditions are given in Table 28 and the running profile is shown in Figure 30.

**Table 28: Test Conditions for HiSpin<sup>®</sup> HS40**

<b>Shaft diameter:</b>	$\varnothing$ 38 mm
<b>Shaft speed:</b>	21,000 rpm
<b>Temperatures:</b>	up to +150°C
<b>Media:</b>	ATF Fluid
<b>Test cycle:</b>	Load cycle according to figure and according to ISO 6149
<b>Test duration:</b>	500 hours

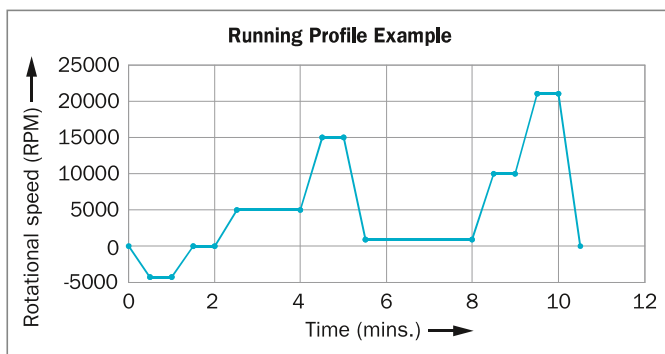

Figure 30: Example running profile showing varying rotational speeds throughout testing

Testing demonstrated noticeably lower volume change in Mobil LV ATF HP media than other commonly used materials (Figure 31). Similarly, when compared with standard Radial Oil Seals, HiSpin<sup>®</sup> HS40 generates significantly less torque, even at high rotational speeds (Figure 32).

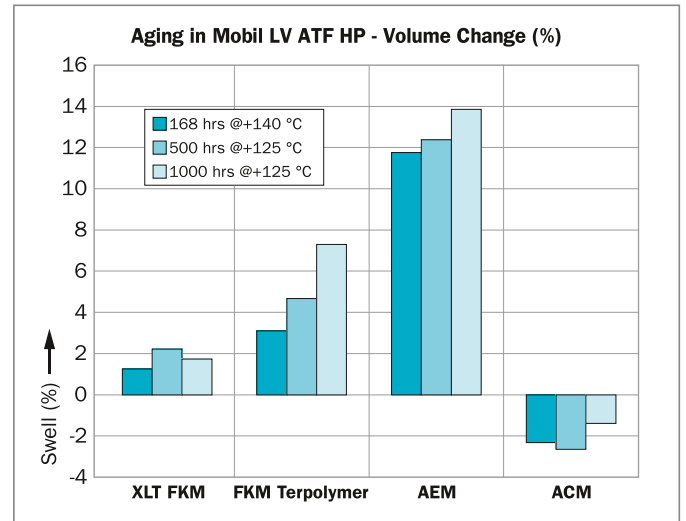

Figure 31: Volume Change (%) for HiSpin<sup>®</sup> HS40 in Mobil LV ATF HP

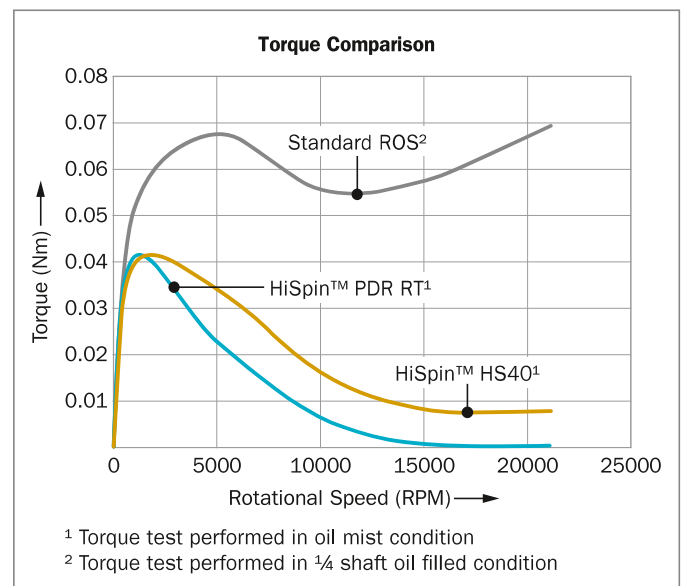

Figure 32: Torque comparison for HiSpin<sup>®</sup> products versus standard Radial Oil Seals.

### ORDERING INFORMATION

Due to the design requirements of this product, contact your local Trelleborg Sealing Solutions marketing company to place an order or for further information.



## ■ Type TRK – Medium Grease

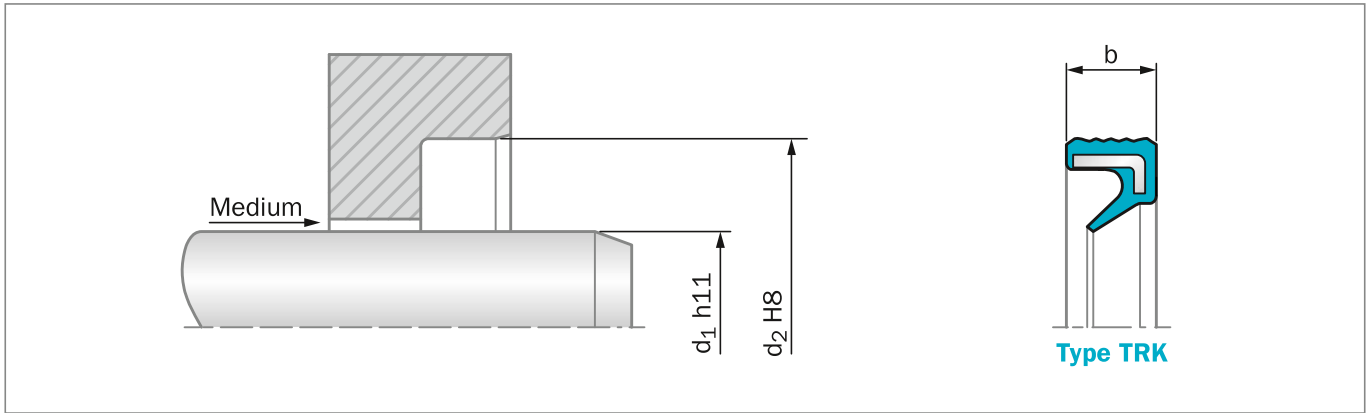

Figure 33: Installation Drawing

### GENERAL DESCRIPTION

The Trelleborg Sealing Solutions Type TRK are specially designed Radial Oil Seals reinforced with a metal insert, but without a spring-energized sealing lip, and a wavy rubber covered outer diameter. Flat rubber covered outer diameter is available on request. These types are not recommended for use in heavily polluted environments.

### ADVANTAGES

- Good static sealing and thermal expansion compensation
- Low friction and low heat generation
- Extremely compact design
- Low radial force provides low break-out torque
- Suitable for scraper applications

### APPLICATION EXAMPLES

- Roller bearings
- Tooling fixtures (e.g. drilling machines)
- Sealing against viscous media (e.g. grease)
- Supplementary excluders (shaft ends)
- Axle King Pin seals

### OPERATING CONDITIONS

<b>Pressure:</b>	Without pressure
<b>Temperature:</b>	-40 °C to +200 °C (depending on material)
<b>Speed:</b>	Up to 10 m/s
<b>Media:</b>	Mineral and synthetic base greases

Trelleborg Sealing Solutions has carried out several thousand compatibility tests. Please ask your local Trelleborg Sealing Solutions marketing company for details.

### IMPORTANT NOTE

The above data are maximum values and cannot be used at the same time, e.g. the maximum operating speed depends on material type, pressure and temperature.

**Table 29: Materials**

TSS Compound Reference	Standard Compound	Temperature °C	Standard Metal insert	Standard spring
N7LMR	NBR (70 Shore A)	-30 °C - 100 °C	Carbon steel	Carbon steel
VCBMR	FKM (70 Shore A)	-20 °C - 200 °C	Carbon steel	Stainless steel

Special grades and other materials (ACM, EACM, EPDM, HNBR, VMQ) on request.  
Metal insert and spring, can be supplied in different materials on request.

**ORDERING EXAMPLE OIL SEAL TSS TYPE**

<b>TSS Type:</b>	K	
<b>Code:</b>	TRKD	
<b>Dimensions:</b>	Shaft diameter	17 mm
	Housing diameter	23 mm
	Width	3 mm
<b>Material:</b>	NBR	
<b>Material Code:</b>	N7LMR	

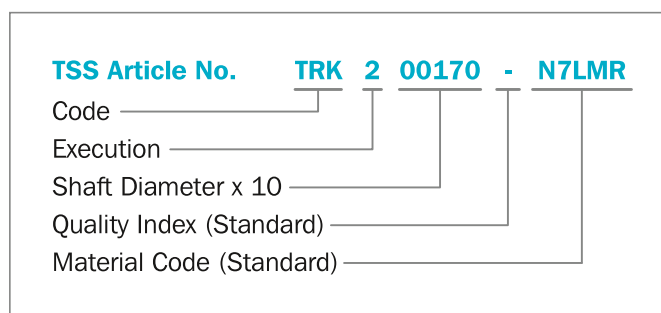
**Table 30: Preferred Series / Dimension, TSS Part Numbers**

Dimension			TSS Part No.	Material	
d <sub>1</sub>	d <sub>2</sub>	b		NBR	FKM
4	8	2	TRK000040	●	●
4	9	2	TRK100040	●	
5	9	2	TRK000050	●	●
5	10	2	TRK100050	●	●
6	10	2	TRK000060	●	●
6	15	3	TRK400060	●	
6	15	4	TRK200060	●	●
6	19	4	TRK300060	●	
7	11	2	TRK000070	●	
8	12	3	TRK000080	●	
8	15	3	TRK200080	●	
9	13	3	TRK000090	●	●
9	16	3	TRK200090	●	
10	12	2	TRK100060	●	
10	14	3	TRK000100	●	●
10	17	3	TRK100100	●	●
10	19	3	TRK200100	●	
10	26	4	TRK400100	●	
11	15	3	TRK000110	●	
12	16	3	TRK000120	●	●
12	18	3	TRK100120	●	●
12	19	3	TRK200120	●	●
13	19	3	TRK000130	●	
14	20	3	TRK000140	●	●
14	21	3	TRK100140	●	
15	21	3	TRK000150	●	●
15	23	3	TRK100150	●	●
16	22	3	TRK000160	●	●
16	22	4	TRK100160		●
16	24	3	TRK200160	●	
16	25	3	TRK300160		●
17	23	3	TRK000170	●	●
17	23.5	3.4	TRK200170	●	
17	25	3	TRK100170	●	
18	24	3	TRK000180	●	
19	26	4	TRK100190	●	
19	27	4	TRK000190	●	
20	26	3	TRK000200	●	●
20	26	4	TRK100200	●	
20	28	4	TRK200200	●	●
20	48	4	TRK300200	●	
22	28	4	TRK000220	●	●
24	32	4	TRK000240	●	
25	32	4	TRK000250	●	●
25	33	4	TRK100250	●	●
25	35	4	TRK200250	●	●

● In one of the preferred materials  
○ In other commercial materials



Dimension			TSS Part No.	Material	
d <sub>1</sub>	d <sub>2</sub>	b		NBR	FKM
26	34	4	<a href="#">TRK000260</a>	●	●
28	35	4	<a href="#">TRK000280</a>	●	
28	35	5	<a href="#">TRK400280</a>	●	
28	37	4	<a href="#">TRK100280</a>		●
30	37	4	<a href="#">TRK000300</a>	●	●
30	40	4	<a href="#">TRK100300</a>	●	●
32	42	4	<a href="#">TRK000320</a>	●	●
33	40	3	<a href="#">TRK100330</a>	●	
35	41	4	<a href="#">TRK000350</a>	●	●
35	42	2	<a href="#">TRK300350</a>	●	
35	42	4	<a href="#">TRK100350</a>	●	
35	45	4	<a href="#">TRK200350</a>	●	
38	48	4	<a href="#">TRK000380</a>	●	
40	47	4	<a href="#">TRK000400</a>	●	
40	48	4	<a href="#">TRK100400</a>		
40	50	4	<a href="#">TRK200400</a>	●	●
42	49	3	<a href="#">TRK100420</a>		●
42	52	4	<a href="#">TRK000420</a>	●	
45	52	4	<a href="#">TRK000450</a>	●	
45	55	4	<a href="#">TRK100450</a>	●	
45	62	8	<a href="#">TRKB00450</a>	●	
48	58	4	<a href="#">TRK000480</a>	●	
50	58	4	<a href="#">TRK000500</a>	●	●
50	60	6	<a href="#">TRK100500</a>	●	
50	62	5	<a href="#">TRK200500</a>	●	
55	63	5	<a href="#">TRK000550</a>	●	●
55	73	8.5	<a href="#">TRK100550</a>	●	
60	68	4	<a href="#">TRK200600</a>		●
60	72	3	<a href="#">TRK100600</a>	●	
60	72	4	<a href="#">TRK000600</a>	●	
70	78	5	<a href="#">TRK000700</a>	●	●
70	81.5	6	<a href="#">TRK100700</a>	●	
74	83	6	<a href="#">TRK100740</a>	●	
74	83	11	<a href="#">TRK000740</a>	●	
75	95	7	<a href="#">TRK000750</a>	●	
120	130	7	<a href="#">TRK001200</a>	●	

- In one of the preferred materials
- In other commercial materials



## ■ Type TRG – Medium Grease

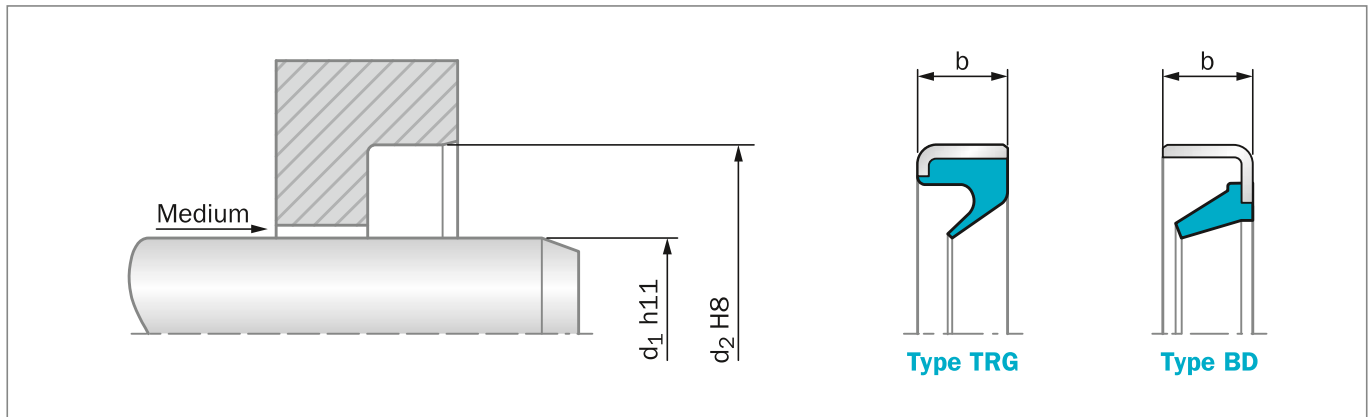

Figure 34: Installation Drawing

### GENERAL DESCRIPTION

The Trelleborg Sealing Solutions Type TRG and STEFA Type BD are special metal cased Radial Oil Seals without spring energized sealing lips. These types are not recommended for use in heavily polluted environments. As the static sealing between housing and metallic shell is limited, low viscosity media can "creep". Better performance can be achieved with Epoxy based resin outer diameter coatings. This special treatment is available on request.

### ADVANTAGES

- Good radial stiffness
- Good fitting stability avoiding pop-out of the seal
- Low friction and low heat generation
- Extremely compact design
- Low radial force provides a low break-out torque
- Suitable for scraper applications

### APPLICATION EXAMPLES

- Roller bearings
- Tooling fixtures (e.g. drilling machines)
- Sealing against viscous media (e.g. grease)
- Supplementary excluders (shaft ends)
- Axle King Pin seals

### OPERATING CONDITIONS

<b>Pressure:</b>	Without pressure
<b>Temperature:</b>	-40 °C to +200 °C (depending on material)
<b>Speed:</b>	Up to 10 m/s
<b>Media:</b>	Mineral and synthetic base greases

Trelleborg Sealing Solutions has carried out several thousand compatibility tests. Please ask your local Trelleborg Sealing Solutions marketing company for details.

### IMPORTANT NOTE

The above data are maximum values and cannot be used at the same time, e.g. the maximum operating speed depends on material type, pressure and temperature.



**Table 31: Materials**

TSS Compound Reference	Standard Compound	Temperature °C	Standard Metal insert	Standard spring
N7MLR	NBR (70 Shore A)	-30 °C - 100 °C	Carbon steel	Carbon steel
4N01	NBR (75 Shore A)	-30 °C - 100 °C	Carbon steel	Carbon steel
VCBMR	FKM (70 Shore A)	-20 °C - 200 °C	Carbon steel	Stainless steel
4V01	FKM (75 Shore A)	-20 °C - 200 °C	Carbon steel	Stainless steel

Special grades and other materials (ACM, EACM, EPDM, HNBR, VMQ) on request.  
 Metal insert and spring can be supplied in different materials on request.

**ORDERING EXAMPLE OIL SEAL TSS TYPE**

<b>TSS Type:</b>	G	
<b>Code:</b>	TRG	
<b>Dimensions:</b>	Shaft diameter	70 mm
	Housing diameter	78 mm
	Width	5 mm
<b>Material:</b>	NBR	
<b>Material Code:</b>	N7LMR	

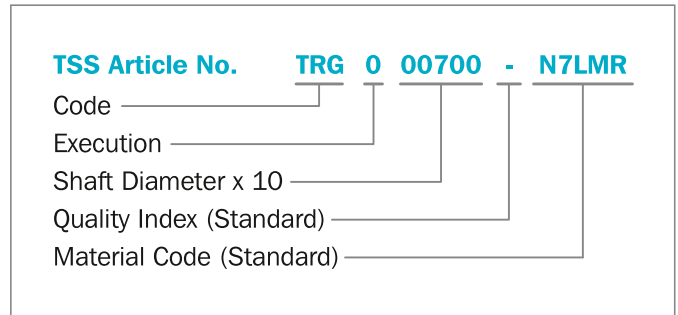





Table 32: Preferred Series / Dimension, TSS Part Numbers

Dimension			TSS Part No.	Material	
d <sub>1</sub>	d <sub>2</sub>	b		NBR	FKM
3	8	2	TRG000030	●	
3	10	6	TRG100030		●
4	8	2	TRG000040		●
5	9	2	TRG000050	●	
6	10	2	TRG000060	●	●
6	12	2	TRG100060	●	
7	11	2	TRG000070	●	●
8	14	2	TRG100080	●	
8	15	3	TRG200080	●	
12	16	3	TRG000120	●	●
13	19	3	TRG000130	●	
14	22	3	TRG200140	●	
15	21	3	TRG000150	●	
15	23	3	TRG100150		●
16	20	2.5	TRG000160	●	
16	24	3	TRG200160	●	
16	24	4	TRG100160		●
16	25	3	TRG300160	●	
17	23	3	TRG000170	●	
18	24	3	TRG000180	●	●
19	26	2	TRG400190	●	
20	24	2.5	TRG300200	●	
20	26	3	TRG100200	●	●
20	26	4	TRG100200	●	
20	28	4	TRG200200	●	●
22	28	4	TRG000220	●	
24	32	4	TRG000240	●	
25	32	4	TRG000250	●	●
25	33	4	TRG100250	●	
25	35	4	TRG200250	●	
27	35	2	TRG000270	●	
28	37	4	TRG100280	●	
30	37	4	TRG000300	●	
30	40	4	TRG100300	●	
32	42	4	TRG000320	●	
35	42	2	TRG200350	●	
35	42	4	TRG100350	●	●
35	72	4	TRG400350	●	
38	48	4	TRG000380	●	
38.1	48	2	TRG000381	●	
40	47	4	TRG000400	●	
40	50	4	TRG200400	●	

Dimension			TSS Part No.	Material	
d <sub>1</sub>	d <sub>2</sub>	b		NBR	FKM
40	52	5	TRG300400	●	
43	53	4	TRG000430	●	
45	52	4	TRG000450	●	
45	52	3	TRG200450	●	
45	55	4	TRG100450	●	●
50	58	4	TRG000500	●	
55	63	5	TRG000550	●	●
60	72	3	TRG000600		
67	75.5	4.3	TRG000670	●	
77	85.5	4.8	TRG000770	●	

● In one of the preferred materials  
○ In other commercial materials



## Turbo Seals with Hydrodynamic Sealing Aids

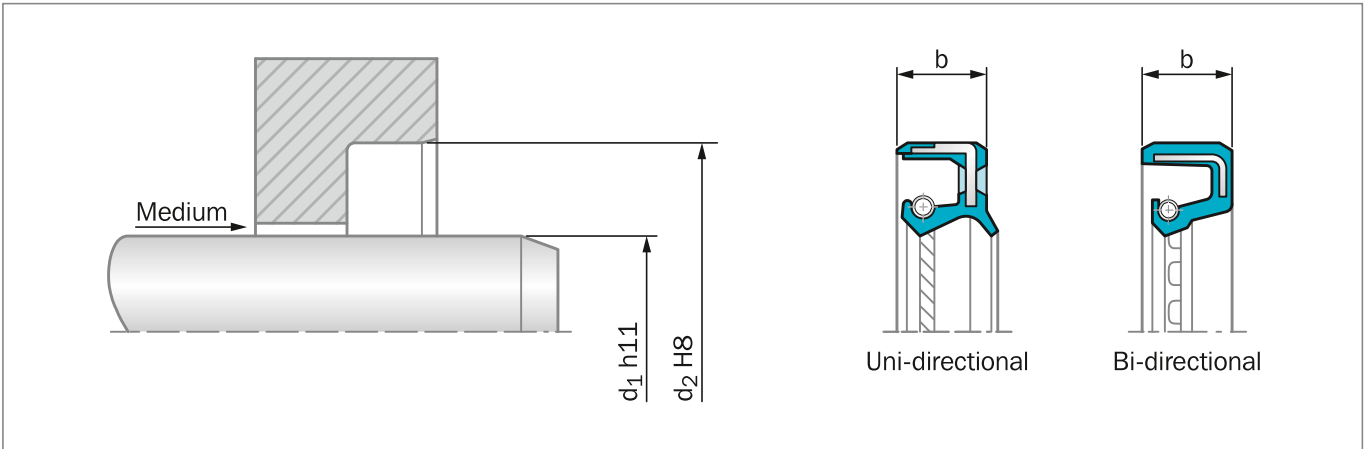

Figure 35: Installation Drawing

### GENERAL DESCRIPTION

Trelleborg Sealing Solutions Turbo Seals are a range of seals with specially-shaped lips, including added ribs or other geometric features.

Optimum conditions are attained when a thin film of lubricant is formed so the lip does not come in to contact with the shaft, which the Turbo Seals create.

The hydrodynamic sealing aids support the sealing function by increasing shaft speed.

The frictional loss of the Turbo Seals is significantly lower than that caused by conventional radial seals without hydrodynamic sealing aids.

The pumping effect starts at a relatively low shaft speed. The pumping effect is understood as the capacity of the seal to pump the sealed medium from the air side to the medium side. In order to avoid leakage at low speed or at standstill, Turbo Seals include a static sealing edge which provides a continuous contact line against the shaft.

### FRICION

The use of certain materials for the sealing element is limited primarily by the heat generated by friction, superimposed on the ambient temperature.

Owing to the enhanced formation of a lubrication film, Turbo Seals can be used for appreciably higher peripheral speeds than conventional seals made of the same material. Figure 36 shows the frictional losses of conventional seals, single-acting and bi-directional Turbo Seals, as determined during comparative laboratory tests. Turbo Seals can withstand

speeds of 16 m/s before reaching the same frictional losses as a conventional seal operating at 10 m/s.

### OPERATING CONDITIONS

<b>Speed:</b>	Up to 20 m/s (depending on material)
<b>Media:</b>	Mineral and synthetic lubricants (CLP, HLP, APGL etc.)

Trelleborg Sealing Solutions has carried out several thousands compatibility tests. Please ask your local Trelleborg Sealing Solutions marketing company details.

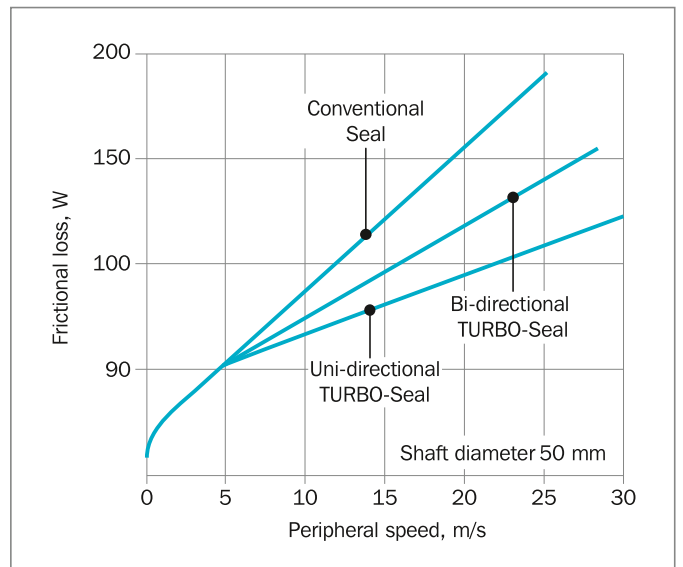

Figure 36: Friction loss

**Table 33: Materials**

TSS Compound Reference	Standard Compound	Temperature °C	Standard Metal insert	Standard spring
N7MMR	NBR (70 Shore A)	-30 °C - 100 °C	Carbon steel	Carbon steel
4N011/4NV11	NBR (75 Shore A)	-30 °C - 100 °C	Carbon steel	Carbon steel
VCBVR	FKM (70 Shore A)	-20 °C - 200 °C	Carbon steel	Stainless steel
4V012	FKM (75 Shore A)	-20 °C - 200 °C	Carbon steel	Stainless steel

Special grades and other materials (ACM, EACM, EPDM, HNBR, VMQ) on request.  
Metal insert and spring can be supplied in different materials on request.

For more details please contact your local Trelleborg Sealing Solutions marketing company.



## ■ Rotary and Axial Seal Combination

### GENERAL DESCRIPTION

Lip seals often fail because of the destruction of the lubricant film due to the ingress of dirt, dust and moisture, resulting in rapid wear. The use of shaft seals with one or more auxiliary sealing lips (dust lips) provides limited improvement, but is not always sufficient. In order to meet the constantly increasing sealing requirements, especially for increased environmental protection and longer service life, the Trelleborg Sealing Solutions COMBI-seal offers a simple solution. It is particularly well suited to critical applications with heavy contamination. The COMBI-seal consists of a GAMMA seal and a rotary shaft lip seal working together. The lip seal provides the counterface for the GAMMA seal which is fixed to the shaft by press fit (see Figure 37 and Figure 38).

Another frequently used alternative for these types of application consists of a V-Ring with a standard Radial Oil Seal type TRC, TRD, TRB, TRF.

The rotary shaft seal should be ordered **"Without Markings"** on the air side.

### RADIAL OIL SEAL + GAMMA SEAL

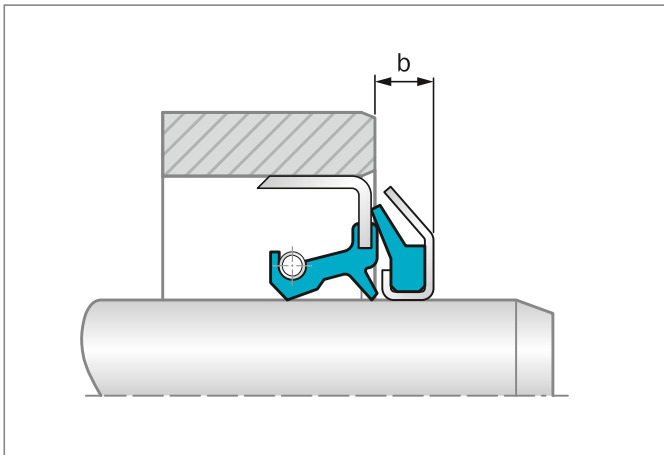

Figure 37: GAMMA seal fitted on the shaft end

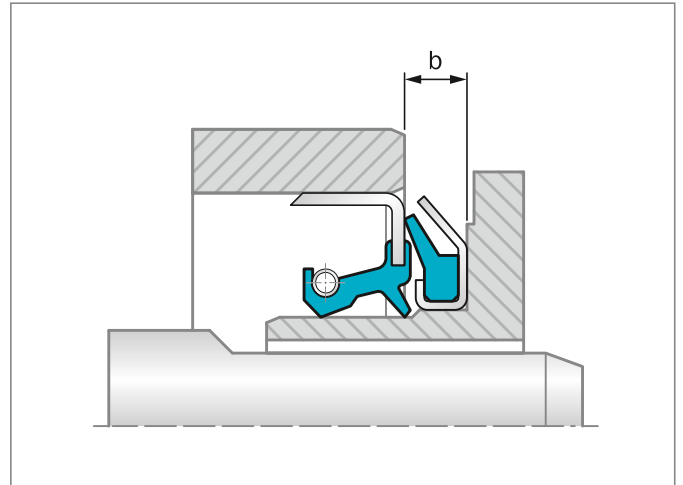

Figure 38: GAMMA seal fitted on the shaft boss

### RADIAL OIL SEAL + V-RING

The function of the rotary axial seal is to prevent intrusion of particles and water through centrifugal forces.

In other words, it adds its original protection capacity to the radial seal functionality. Sufficient space is required on the shaft to host the axial seal width (see Figure 39).

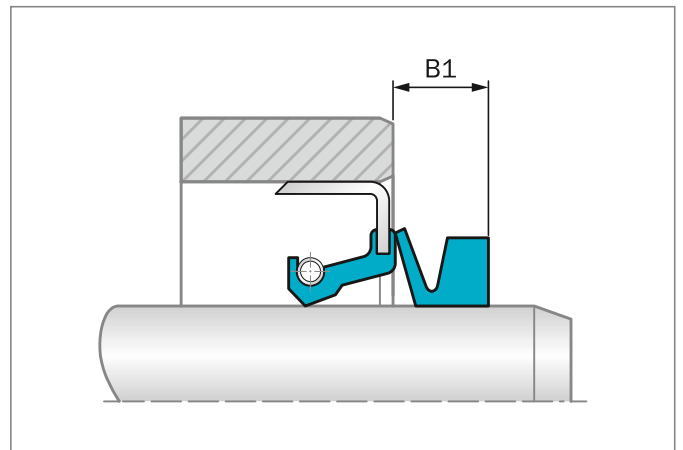

Figure 39: V-Ring fitted on the shaft end

### HOUSING AND SHAFT DESIGN

The radial lip seal needs to be assembled in the housing according to usual fitting instructions. Both the V-Ring and GAMMA seal are assembled later on the shaft. The shaft design requires adaptation by an elongation corresponding at least to B1 (b) dimensions. In case of very high peripheral speeds, the V-Ring body should be radially supported. Also see page 161.



## PRODUCT DESCRIPTION

The combination of radial shaft seal with V-Ring or GAMMA seals is recommended for use in heavily polluted environments.

Both the radial shaft seal and the GAMMA seal housing may also be manufactured with a different metal shell, as well as different rubber types for sealing elements. See specific paragraphs.

## ADVANTAGES

- Longer service life and high function reliability
- Good IP protection for electrical motors (VDE-Norm 0470-1)
- Good protection against water splash and welding sparks
- Simple handling
- Superior total economy
- Friction loss decreases with increasing shaft speed

## APPLICATION EXAMPLES

Typical applications are all equipment working in contaminated environments where dust, foreign matter and liquid splatter are present.

Some examples:

- gear motors
- journal and gear transmissions
- bearing housings
- power saws
- utility vehicles
- agricultural machinery and equipment
- wheel hubs
- propeller shafts
- pumps
- hydraulic motors
- tool machinery
- equipment for steel manufacturing
- metal working machinery

## OPERATING CONDITIONS

<b>Pressure:</b>	See radial seal data
<b>Temperature:</b>	-40 °C to +200 °C (depending on material)
<b>Speed:</b>	Up to 10 m/s (depending on material)
<b>Media:</b>	Mineral and synthetic oils (CLP, HLP, APGL etc.)

Trelleborg Sealing Solutions has carried out several thousands compatibility tests. Please ask your local Trelleborg Sealing Solutions marketing company for details.

## IMPORTANT NOTE

The above data are maximum values and cannot be used at the same time, e.g. the maximum operating speed depends on material type, pressure and temperature.

## MATERIALS

See specific chapters.

## ORDERING EXAMPLE

Order components separately as per specific chapters. Order the radial oil seals **"without marking"**.



## ■ Type TRJ/TRL

### FIBER REINFORCED OIL SEALS FOR LARGE DIAMETER

Fiber reinforced oil seals contain no metal parts with the exception of the spring. Instead of the metal insert, a reinforced fiber component is molded into the body of the seal. Damage through transport and mounting is consequently excluded.

Fiber reinforced oil seals are mainly used for installation in constructions and equipment with large diameters. The use of an axial retaining plate is necessary except for the type TRJ/F and respectively for the type TRL/F.

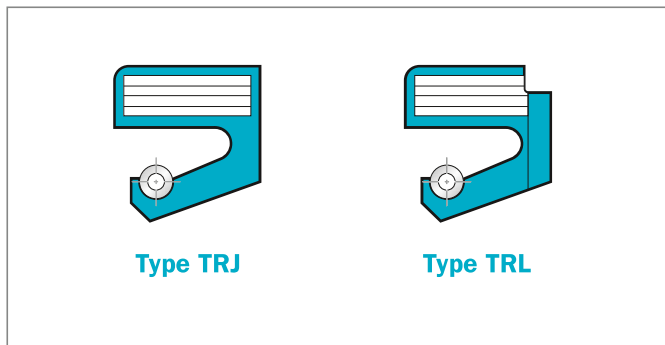

Figure 40: Fiber reinforced design for large diameters

### SPLIT VERSION

To ease the mounting, or in case of repair, the types TRJ and TRL are also available in split versions.

To ensure effective sealing at the split ends, a full rubber section is molded at the join so that contact between homogeneous elastic surfaces maximizes the sealing effect. The interface should always be above the oil level.

If two seals in split versions are mounted together, the interface should be turned a minimum of 30° to the side.

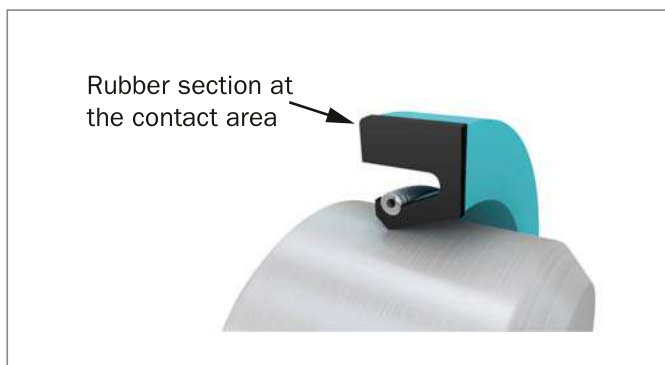

Figure 41: Contact area, split seal

### SEPARATION OF TWO MEDIA WITH TYPE TRL

A single oil seal should not be used for the separation of two media. In such cases, two seals are fitted in a back to back arrangement. The type TRL is suitable for the sealing of large diameters. It is a special design with peripheral and radial grooves where a lubricant could be applied.

The peripheral groove on the seal reduces the need to cut a groove in the housing (see Figure 42).

The seal can be used for:

- Isolation of two media
- If lubrication is necessary from the outside

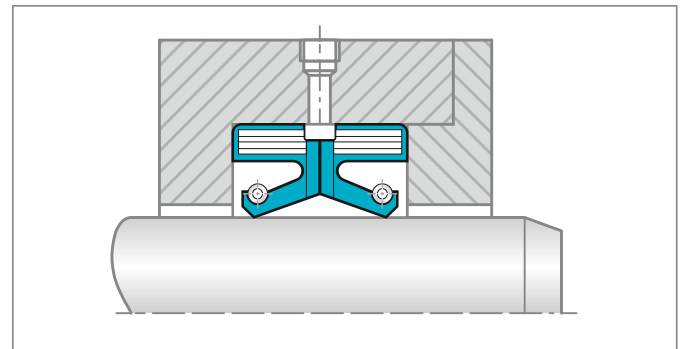

Figure 42: Type TRL mounted back to back

### SPECIAL DESIGN TRJ/F AND TRL/F WITH REINFORCED SHOULDER

Whenever a retaining plate cannot be fitted we can supply a seal made in a special hardened compound, namely type TRJ/F and TRL/F, which makes the seal self-retaining and providing effective sealing at the O.D.

Trelleborg Sealing Solutions type TRJ/F and TRL/F are supplied in standard form and are not available in split versions (see Figure 43).

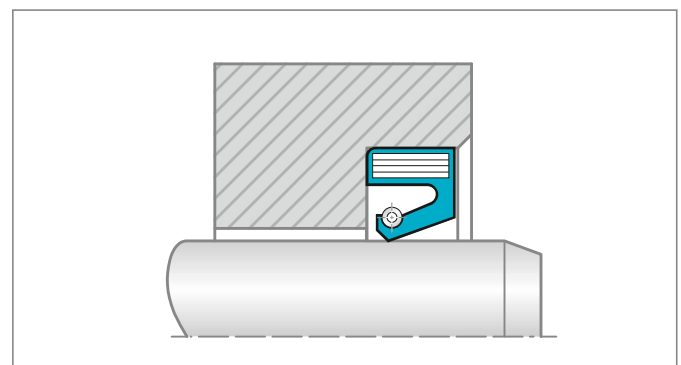

Figure 43: Type TRJ/F mounted without axial retaining plate



## DESIGN INSTRUCTIONS

### Installation on the shaft

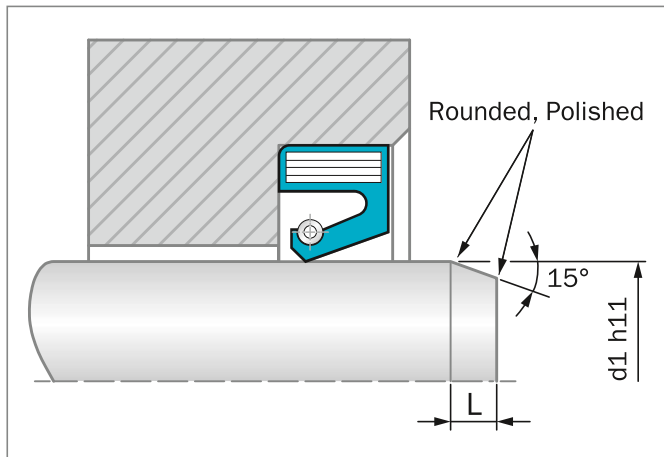

Figure 44: Installation of the oil seal

To facilitate the installation of the seal with minimum risk of lip damage, the shaft require a 15° chamfer with length "L" as the function of its diameter "d1".

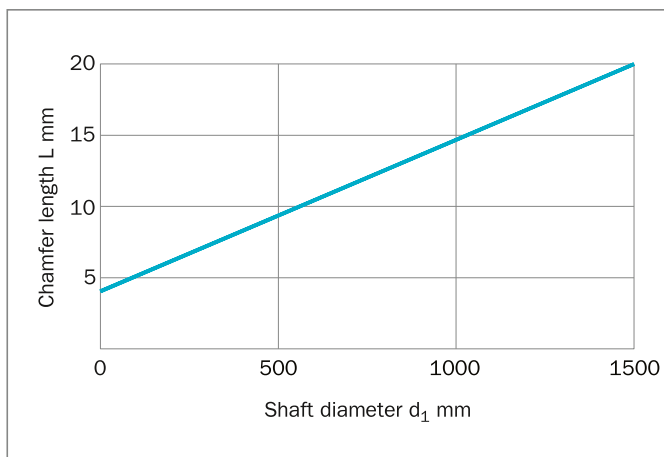

Figure 45: Chamfer length as a function of the shaft diameter

### Eccentricity

Eccentricity between the shaft and housing bore centers should be avoided in order to eliminate unilateral load of the lip.

**Table 34: Static Eccentricity**

d1	b x f (mm)	max. stat. Ecc. (mm)
100 - 250	16 x 20	0.50
250 - 400	20 x 22	0.55
400 - 600	22 x 25	0.62
> 600	25 x 32	0.70

### Shaft run out

Shaft run out should be avoided or kept to a minimum. At higher speeds there is a risk that the inertia of the sealing lip prevents it from following the shaft movement. The seal must be located next to the bearing and the bearing play be maintained at the minimum value possible.

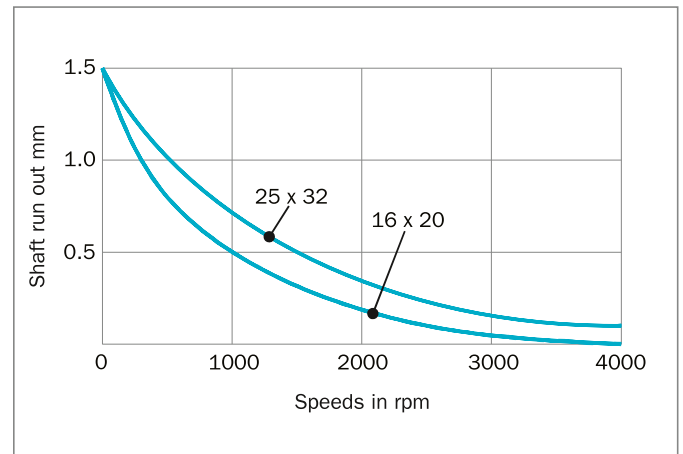

Figure 46: Shaft run out

### Installation in the gland

The static seal in the mounting bore is provided by the corresponding force fit allowance at the outer sheath of the seal.

The bore tolerance is specified to DIN ISO 286T2-H8.

Values for the surface roughness in the gland are specified in ISO 6194/1.

General values:	Ra	=	1.6 - 3.2 $\mu\text{m}$
	Rz	=	6.3 - 12.5 $\mu\text{m}$

For gas sealing, a good score-free and spiral-free surface finish is necessary. If the rotary shaft lip seal is bonded into the housing, ensure that no adhesive comes into contact with the sealing lip or the shaft.

The bore  $d_2$  of the sealing housing indicated in Table 34 as a function of shaft diameter. ( $d_2 = d_1 + 2 \times f$ ), see page 105.

The width (b) including the tolerance is also given in Table 35.



### INSTALLATION, TYPE TRJ

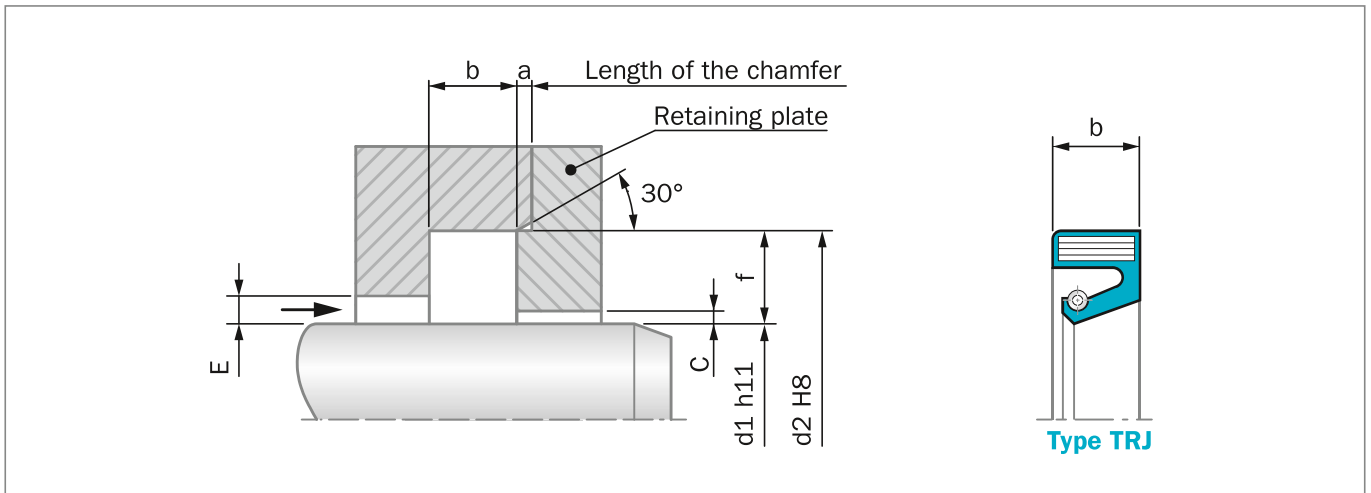

Figure 47: Installation Drawing

### INSTALLATION, TYPE TRL

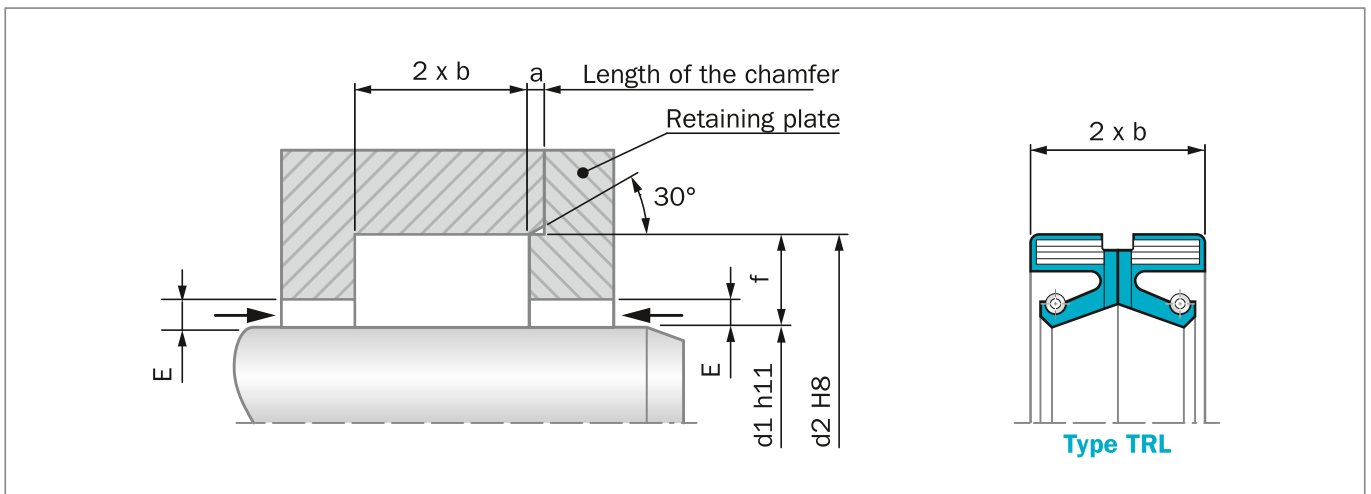

Figure 48: Installation Drawing

**Table 35: Dimensions**

d1	b x f	a	E	C	b
100 - 250	16 x 20	2.0	9	4	16 ±0.1
250 - 400	20 x 22	2.2	11	6	20 ±0.2
400 - 600	22 x 25	2.5	11	7	22 ±0.2
> 600	25 x 32	3.2	14	8	25 ±0.2





## OPERATING CONDITIONS, TYPE TRJ AND TRL

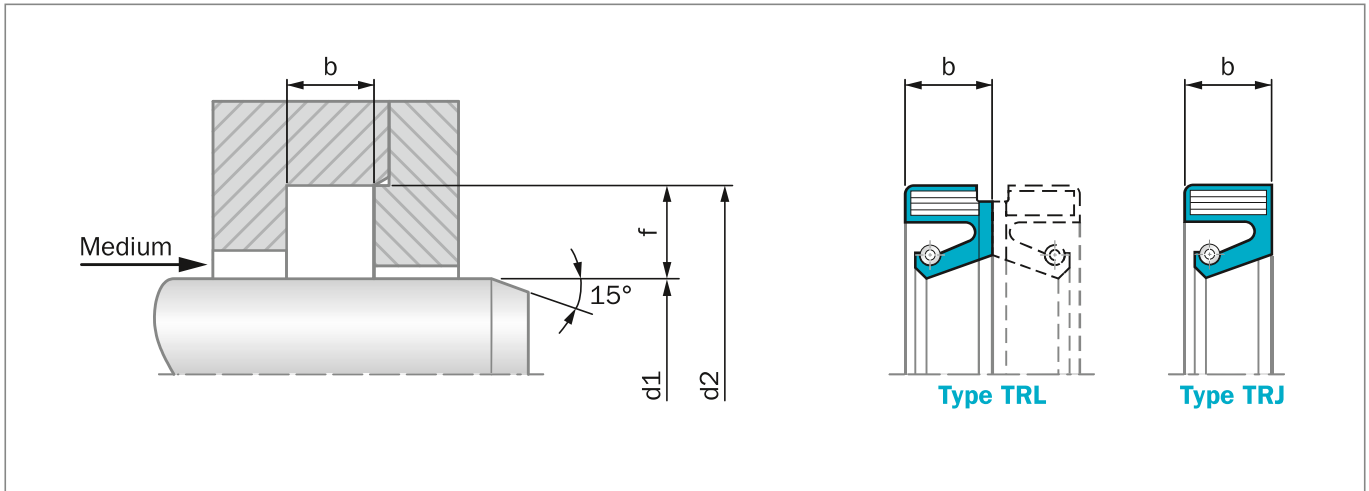

Figure 49: Installation Drawing

**Table 36: Material**

Standard-Material*	TSS Material Code	Standard Spring
NBR (75 Shore A)	4NC01	Carbon steel
HNBR (75 Shore A)	4HC01	Carbon steel
FKM (75 Shore A)	4VC02	Stainless steel

\* The spring can be supplied in different materials on request.

**Table 37: Operating Conditions**

Type	Temperature	Speed	Pressure	Dimensions
TRJ	-30 °C to +200 °C	up to 25 m/s	0.05 MPa	100 - 1,890
TRL	-30 °C to +200 °C	up to 25 m/s	0.05 MPa	100 - 1,890

## ORDERING EXAMPLE

<b>TSS Type:</b>	J	
<b>Code:</b>	TRJ	
<b>Dimensions:</b>	Shaft diameter	100 mm
	Housing diameter	125 mm
	Width	12.5 mm
<b>Material:</b>	NBR	
<b>Material Code:</b>	4NC01	

<b>TSS Article No.</b>	<b>TRJ</b>	<b>001000</b>	<b>-</b>	<b>4NC01</b>
TSS Code	_____			
Shaft Diameter x 10	_____			
Quality Index (Standard)	_____			
Material	_____			



**Table 38: Preferred Series / Dimension, TSS Part Numbers**

Dimension			TSS Part No.	Material		Dimension			TSS Part No.	Material	
d <sub>1</sub>	d <sub>2</sub>	b		NBR	FKM	d <sub>1</sub>	d <sub>2</sub>	b		NBR	FKM
100	125	12.5	TRJ001000	●		405	445	20	TRJ004050	●	
115	140	15	TRJ001150		●	430	474	20	TRL004300	●	●
120	150	13	TRJ001200	●		440	490	22	TRJ004400	●	●
125	160	12	TRJ001250	●		445	495	22	TRJ004450	●	
130	170	16	TRJ001300	●		450	500	22	TRJ004500	●	
133	165	12.5	TRL001330	●		460	504	20	TRL004600	●	
145	175	15	TRJ001450	●		470	520	25	TRJ004700	●	
150	180	13	TRJ001500	●	●	480	530	22	TRJ004800	●	●
170	200	15	TRJ001700	●		480	530	22	TRL004800	●	
175	215	16	TRL001750	●		490	534	20	TRL004900	●	
180	218.1	15.9	TRJ001800	●		500	544	22	TRJ005000	●	
190	220	16	TRJ001900	●		530	580	22	TRJ005300	●	
200	230	14	TRL002000	●		540	590	22	TRJ005400	●	
200	240	16	TRJ002000	●		540	590	22	TRL005400	●	●
220	260	16	TRJ002200	●		560	610	22	TRJ005600	●	
220	270	16	TRJ202200	●		570	620	22	TRL005700	●	●
230	260	15.7	TRJ002300	●		596	660	32	TRL005960	●	
240	270	15	TRJ002400	●		600	650	22	TRJ006000	●	
240	280	16	TRJ302400	●		625	670	20	TRJ006250	●	
250	280	16	TRL002500	●		630	680	22	TRL006300	●	●
250	290	16	TRJ102500		●	640	690	22	TRJ006400	●	
260	290	16	TRJ002600	●		650	700	22	TRJ006500	●	
260	300	14	TRL002600	●		650	714	25	TRL006500	●	
260	304	20	TRJ102600	●	●	660	704	20	TRJ106600	●	
270	310	18	TRL002700	●		680	730	20	TRJ006800	●	
270	310	20	TRJ002700	●	●	696	760	32	TRL006960	●	
280	320	16	TRJ102800	●		700	750	25	TRL007000	●	
280	324	20	TRJ202800	●		710	760	24.5	TRL107100	●	
290	334	20	TRJ002900	●		710	760	25.5	TRL007100	●	
300	340	18	TRL003000	●		730	794	25	TRJ007300	●	
310	340	14.5	TRJ103100	●		735	799	25	TRJ007350		●
310	350	20	TRJ003100	●		750	810	25	TRL107500	●	
315	355	16	TRJ003150		●	750	814	25	TRL007500	●	
320	360	18	TRJ003200	●		762	810	20	TRL007620	●	
320	364	20	TRJ103200	●		766	830	32	TRL007660	●	
330	370	20	TRJ003300	●		775	839	25	TRL007750	●	
350	394	20	TRL003500	●		790	854	25	TRL007900	●	
370	410	18	TRL003700	●		820	870	22	TRL008200	●	
380	420	18	TRL003800	●		860	900	18	TRJ008600	●	
380	420	20	TRJ003800	●		860	924	25	TRL008600	●	
390	434	20	TRJ003900	●		880	944	25	TRL008800	●	●
400	440	18	TRL004000	●		970	1,034	25	TRJ009700		●
400	444	20	TRJ104000	●		1,100	1,164	25	TRL0X1100	●	●



Table 39: Further dimensions for Type TRJ/TRL

Dimensions				Type		Dimensions				Type	
d <sub>1</sub>	d <sub>2</sub>	b	f	TRJ	TRL	d <sub>1</sub>	d <sub>2</sub>	b	f	TRJ	TRL
100.0	115.0	8.9	7.5	●		120.0	140.0	13.0	10.0	●	
100.0	115.0	9.0	7.5			120.0	144.0	14.5	10.0	●	
100.0	120.0	13.0	10.0	●		120.0	144.0	15.5	12.0	●	
100.0	125.0	13.0	12.5	●		120.0	145.0	15.5	12.5	●	
100.0	125.0	15.0	12.5	●		120.0	150.0	13.0	15.0	●	
100.0	125.4	12.7	12.7	●	●	120.0	150.0	15.0	15.0	●	
100.0	130.0	12.0	15.0	●		120.0	150.0	16.0	15.0	●	
100.0	130.0	15.0	15.0	●		120.0	152.0	16.0	16.0	●	
100.0	132.0	12.5	16.0	●	●	120.0	160.0	12.0	20.0	●	
100.0	140.0	16.0	20.0	●		120.0	160.0	16.0	20.0	●	
105.0	129.0	13.0	12.0	●		120.0	170.0	15.0	25.0	●	
105.0	130.0	12.0	12.5	●		125.0	140.0	10.0	7.5	●	
105.0	130.0	13.0	12.5	●		125.0	150.0	12.0	12.5	●	
105.0	133.5	12.7	14.3	●		125.0	150.0	15.0	12.5	●	
105.0	137.0	16.0	16.0	●		125.0	153.5	12.7	14.2	●	
105.0	140.0	12.0	17.5	●		125.0	155.0	12.0	15.0	●	
105.0	143.0	16.0	19.0	●		125.0	160.0	12.0	17.5	●	
105.0	145.0	16.0	20.0	●		125.0	160.0	13.0	17.5	●	
110.0	126.0	9.0	8.0	●		125.0	160.0	15.0	17.5	●	
110.0	126.0	12.0	8.0	●		125.0	165.0	15.0	20.0	●	
110.0	130.0	9.0	10.0	●		125.0	165.0	16.0	20.0	●	
110.0	130.0	12.0	10.0	●		127.0	157.0	15.0	15.0	●	
110.0	130.0	13.0	10.0	●		128.0	165.0	15.0	18.5	●	
110.0	135.0	12.0	12.5	●		130.0	150.0	10.0	10.0	●	
110.0	140.0	12.0	15.0	●		130.0	150.0	12.0	10.0	●	
110.0	140.0	14.0	15.0	●		130.0	155.0	10.0	12.5	●	
110.0	140.0	15.0	15.0	●		130.0	155.0	15.5	12.5	●	
110.0	140.0	16.0	15.0	●		130.0	160.0	12.0	15.0	●	
110.0	141.0	13.7	15.5	●		130.0	160.0	15.0	15.0	●	
110.0	145.0	19.0	17.5	●		130.0	160.0	16.0	15.0	●	
110.0	150.0	16.0	20.0	●		130.0	165.0	13.0	17.5	●	
115.0	137.0	8.8	11.0	●		130.0	170.0	13.0	20.0	●	
115.0	137.0	9.0	11.0		●	130.0	170.0	16.0	20.0	●	
115.0	140.0	12.0	12.5	●		133.0	165.0	12.5	16.0		●
115.0	140.0	13.0	12.5	●	●	134.0	169.0	15.0	17.5	●	
115.0	140.4	9.5	12.7	●		135.0	157.0	8.0	11.0	●	
115.0	145.0	12.0	15.0	●		135.0	160.0	12.0	12.5	●	
115.0	145.0	15.0	15.0	●		135.0	165.0	13.0	15.0	●	
115.0	150.0	15.0	17.5	●		135.0	167.0	15.0	16.0	●	
115.0	155.0	16.0	20.0	●		135.0	160.0	12.0	12.5	●	
118.0	140.0	14.0	11.0	●							
120.0	140.0	12.5	10.0	●							

These additional dimensions available on request.  
Please contact Trelleborg sealing solutions.



Dimensions				Type	
d <sub>1</sub>	d <sub>2</sub>	b	f	TRJ	TRL
135.0	165.0	13.0	15.0	●	
135.0	167.0	15.0	16.0	●	
135.0	160.0	12.0	12.5	●	
135.0	165.0	13.0	15.0	●	
135.0	167.0	15.0	16.0	●	
135.0	170.0	12.0	17.5	●	
135.0	170.0	13.0	17.5	●	
135.0	170.0	16.5	17.5	●	
135.0	175.0	16.0	20.0	●	
136.0	160.0	10.0	12.0	●	
138.0	180.0	15.0	21.0	●	
139.0	155.0	10.0	8.0	●	
139.0	169.0	14.6	15.0	●	
140.0	155.0	10.0	7.5	●	
140.0	160.0	13.0	10.0	●	
140.0	165.0	15.0	12.5	●	
140.0	168.0	21.0	14.0	●	
140.0	170.0	15.0	15.0	●	
140.0	180.0	12.0	20.0	●	
140.0	180.0	15.0	20.0	●	●
140.0	180.0	16.0	20.0	●	●
140.0	190.0	15.0	25.0	●	
143.0	165.0	10.0	11.0	●	
144.0	180.0	15.0	18.0	●	
145.0	170.0	13.0	12.5	●	
145.0	170.0	15.0	12.5	●	
145.0	180.0	12.0	17.5	●	
145.0	180.0	14.0	17.5	●	
149.0	179.0	13.0	15.0	●	
149.0	180.0	16.0	15.5	●	
150.0	172.0	12.7	11.0	●	
150.0	180.0	12.0	15.0	●	●
150.0	180.0	13.0	15.0	●	
150.0	180.0	14.0	15.0	●	
150.0	180.0	15.0	15.0	●	
150.0	185.0	15.0	17.5	●	
150.0	188.0	16.0	19.0	●	
150.0	190.0	16.0	20.0	●	●
150.0	190.0	20.0	20.0	●	
152.0	180.0	14.0	14.0	●	
152.0	190.0	19.0	19.0	●	
154.0	180.0	12.2	13.0	●	
155.0	175.0	10.8	10.0	●	
155.0	180.0	12.5	12.5	●	

Dimensions				Type	
d <sub>1</sub>	d <sub>2</sub>	b	f	TRJ	TRL
155.0	180.0	15.0	12.5	●	
155.0	190.0	13.0	17.5	●	
156.0	195.0	15.0	19.5		●
159.0	200.0	16.0	20.5	●	
160.0	188.0	21.0	14.0	●	
160.0	190.0	15.0	15.0	●	
160.0	190.0	16.0	15.0	●	
160.0	200.0	16.0	20.0	●	●
165.0	190.0	15.0	12.5	●	
165.0	195.0	15.0	15.0	●	●
165.0	200.0	15.0	17.5	●	
165.0	203.0	19.0	19.0	●	
165.0	205.0	16.0	20.0	●	
168.0	200.0	16.0	16.0	●	
169.0	200.0	12.0	15.5	●	
169.0	201.0	12.5	16.0	●	
170.0	192.0	10.7	11.0	●	
170.0	195.0	14.2	12.5	●	
170.0	200.0	12.0	15.0	●	●
170.0	200.0	15.0	15.0	●	
170.0	205.0	18.0	17.5	●	
170.0	210.0	16.0	20.0	●	●
170.0	220.0	15.0	25.0	●	
170.0	223.0	20.0	26.5	●	
174.0	214.0	16.0	20.0	●	
175.0	200.0	15.0	12.7	●	
175.0	205.0	15.0	15.0	●	●
175.0	215.0	15.0	20.0	●	
175.0	215.0	16.0	20.0	●	
180.0	200.0	15.0	10.0	●	
180.0	205.0	12.5	12.5	●	
180.0	210.0	12.0	15.0	●	
180.0	210.0	15.0	15.0	●	●
180.0	212.0	16.0	16.0	●	
180.0	215.0	15.0	17.5	●	
180.0	216.0	21.8	18.0	●	
180.0	220.0	13.0	20.0	●	
180.0	220.0	16.0	20.0	●	●
180.0	230.0	16.0	25.0	●	
182.0	215.0	16.0	16.5	●	
185.0	210.0	13.0	12.5	●	
185.0	215.0	15.0	15.0		●

These additional dimensions available on request.  
Please contact Trelleborg sealing solutions.



Dimensions				Type		Dimensions				Type	
d <sub>1</sub>	d <sub>2</sub>	b	f	TRJ	TRL	d <sub>1</sub>	d <sub>2</sub>	b	f	TRJ	TRL
185.0	215.0	16.0	15.0	●		216.0	241.5	12.7	12.7	●	
185.0	220.0	16.0	17.5	●		216.0	254.0	16.0	19.0	●	
185.0	225.0	16.0	20.0	●	●	216.0	254.0	19.0	19.0	●	
185.0	230.0	16.0	22.5	●		216.9	254.0	19.0	18.5	●	
190.0	210.0	15.0	10.0	●		218.0	245.0	12.5	13.5	●	
190.0	212.0	11.7	11.0	●		218.0	270.0	22.0	26.0	●	
190.0	215.0	16.0	12.5	●		220.0	245.0	12.5	12.5	●	●
190.0	220.0	15.0	15.0	●	●	220.0	250.0	12.0	15.0	●	
190.0	220.0	16.0	15.0	●		220.0	250.0	15.0	15.0	●	●
190.0	225.0	18.0	17.5	●		220.0	250.0	16.0	15.0	●	
190.0	230.0	15.0	20.0	●		220.0	250.0	19.0	15.0	●	
190.0	230.0	16.0	20.0	●	●	220.0	254.0	16.0	17.0	●	
195.0	220.0	15.0	12.5	●		220.0	255.0	16.0	17.5	●	
195.0	230.0	15.0	17.5	●		220.0	255.0	18.0	17.5	●	
195.0	230.0	16.0	17.5	●		220.0	258.0	25.4	19.0	●	
195.0	235.0	16.0	20.0	●		220.0	260.0	15.0	20.0	●	
196.0	228.0	16.0	16.0	●		220.0	260.0	16.0	20.0	●	●
196.0	235.0	19.0	19.5	●		220.0	260.0	20.0	20.0	●	
200.0	225.0	15.0	12.5	●		220.0	260.0	22.0	20.0	●	
200.0	230.0	15.0	15.0	●	●	220.0	270.0	16.0	25.0	●	
200.0	230.0	16.0	15.0	●		225.0	250.0	12.5	12.5	●	
200.0	235.0	18.2	17.5	●		225.0	260.0	16.0	17.5	●	
200.0	240.0	15.0	20.0	●		225.0	270.0	16.0	22.5	●	
200.0	240.0	16.0	20.0	●	●	226.0	258.0	16.0	16.0	●	
200.0	250.0	15.0	25.0	●		228.0	268.0	16.0	20.0		●
200.0	250.0	18.0	25.0	●		228.0	268.0	20.0	20.0	●	
205.0	230.0	16.0	12.5	●		230.0	255.0	10.0	12.5	●	
205.0	245.0	16.0	20.0	●		230.0	255.0	11.7	12.5	●	
205.0	245.0	20.0	20.0	●		230.0	255.0	15.0	12.5	●	
205.0	250.0	16.0	22.5	●		230.0	260.0	12.5	15.0	●	
210.0	240.0	13.0	15.0	●		230.0	260.0	15.0	15.0	●	
210.0	245.0	15.0	17.5	●		230.0	260.0	16.0	15.0	●	
210.0	245.0	18.0	17.5	●		230.0	265.0	18.0	17.5	●	
210.0	246.0	16.0	18.0	●		230.0	270.0	16.0	20.0	●	●
210.0	250.0	15.0	20.0	●		230.0	280.0	15.0	25.0	●	
210.0	250.0	16.0	20.0	●	●	230.0	280.0	23.0	25.0		●
210.0	274.0	26.0	32.0	●		230.0	285.0	23.0	27.5	●	
213.0	248.0	16.0	17.5	●		234.9	273.0	19.0	19.1	●	
215.0	240.0	12.0	12.5	●		235.0	270.0	16.0	17.5	●	
215.0	245.0	16.0	15.0	●	●	235.0	270.0	18.0	17.5	●	
215.0	247.0	12.5	16.0	●		235.0	275.0	20.0	17.5	●	
215.0	248.0	15.0	16.5	●		236.0	276.0	16.0	20.0		●
215.0	251.0	12.5	18.0	●							
215.0	265.0	17.0	25.0	●							

These additional dimensions available on request.  
Please contact Trelleborg sealing solutions.



Dimensions				Type	
d <sub>1</sub>	d <sub>2</sub>	b	f	TRJ	TRL
240.0	270.0	15.0	15.0	●	
240.0	270.0	17.0	15.0	●	
240.0	275.0	18.0	20.0	●	
240.0	278.0	17.0	19.0	●	
240.0	280.0	16.0	20.0	●	●
240.0	280.0	17.5	20.0	●	
245.0	270.0	13.0	12.5	●	
245.0	270.0	16.0	12.5	●	●
250.0	280.0	15.0	15.0	●	
250.0	280.0	16.0	15.0	●	●
250.0	285.0	18.0	17.5	●	
250.0	285.0	20.0	17.5	●	
250.0	288.0	19.0	19.0	●	
250.0	290.0	16.0	20.0	●	●
250.0	300.0	20.0	25.0	●	
250.0	303.0	20.0	26.5	●	
250.0	310.0	25.0	30.0	●	
253.0	285.0	11.0	16.0	●	
254.0	279.0	9.3	12.5	●	
254.0	292.0	15.9	19.0	●	
255.0	285.0	11.0	15.0	●	●
255.0	285.0	15.0	15.0	●	
255.0	295.0	16.0	20.0	●	●
255.0	310.0	18.0	27.5	●	
258.0	290.0	16.0	16.0	●	●
260.0	285.0	18.0	12.5	●	
260.0	290.0	16.0	15.0	●	●
260.0	290.0	19.0	15.0	●	
260.0	292.0	12.5	16.0	●	
260.0	298.0	17.0	19.0	●	
260.0	300.0	18.0	20.0	●	
260.0	300.0	20.0	20.0	●	
260.0	304.0	20.0	22.0	●	●
260.0	305.0	16.0	22.5	●	
260.0	305.0	22.0	22.5	●	
260.0	310.0	16.0	25.0	●	
260.0	310.0	18.0	25.0	●	
264.0	309.0	21.5	22.5	●	
265.0	300.0	16.0	17.5	●	●
265.0	310.0	16.0	22.5	●	
265.0	310.0	22.0	22.5	●	
270.0	300.0	15.0	15.0	●	●
270.0	310.0	16.0	20.0	●	
270.0	310.0	20.0	22.0	●	

Dimensions				Type	
d <sub>1</sub>	d <sub>2</sub>	b	f	TRJ	TRL
270.0	314.0	20.0	22.0	●	●
272.0	304.0	16.0	16.0	●	
272.0	304.0	16.5	16.0	●	
273.0	317.0	19.0	22.0	●	
275.0	310.0	15.0	17.5	●	
277.0	317.0	19.0	20.0	●	
280.0	310.0	15.0	15.0	●	
280.0	310.0	16.0	15.0	●	
280.0	318.0	15.0	19.0	●	
280.0	320.0	16.0	20.0	●	●
280.0	320.0	18.0	20.0	●	
280.0	320.0	20.0	20.0	●	
280.0	324.0	20.0	22.0	●	
280.0	325.0	24.0	22.5	●	
285.0	310.0	16.0	12.5	●	
285.0	325.0	16.0	20.0		●
285.0	325.0	18.0	20.0	●	
286.0	330.0	16.0	22.0	●	
290.0	320.0	15.0	15.0	●	
290.0	322.0	12.5	16.0	●	
290.0	330.0	16.0	20.0	●	
290.0	330.0	18.0	20.0	●	
290.0	330.0	20.0	20.0	●	
290.0	334.0	20.0	22.0	●	●
290.0	335.0	20.0	22.5	●	
290.0	350.0	25.0	30.0	●	
295.0	325.0	15.0	15.0	●	
295.0	335.0	15.0	20.0		●
295.0	335.0	16.0	20.0	●	
295.0	339.0	20.0	22.0	●	
300.0	330.0	14.0	15.0		●
300.0	332.0	15.0	16.0	●	
300.0	332.0	16.0	16.0	●	
300.0	335.0	16.0	17.5	●	
300.0	335.0	18.0	17.5	●	●
300.0	340.0	16.0	20.0	●	●
300.0	340.0	18.0	20.0	●	●
300.0	340.0	20.0	20.0	●	
300.0	340.0	25.0	20.0	●	
300.0	344.0	20.0	22.0	●	●
300.0	344.0	22.0	22.0	●	
300.0	350.0	22.0	25.0	●	

These additional dimensions available on request.  
Please contact Trelleborg sealing solutions.



Dimensions				Type		Dimensions				Type	
d <sub>1</sub>	d <sub>2</sub>	b	f	TRJ	TRL	d <sub>1</sub>	d <sub>2</sub>	b	f	TRJ	TRL
300.0	350.0	25.0	25.0	●		340.0	370.0	20.0	15.0	●	
300.0	360.0	25.0	30.0	●		340.0	372.0	16.0	16.0	●	
300.0	364.0	25.0	32.0	●		340.0	373.0	16.0	16.5	●	
300.0	370.0	18.0	35.0	●		340.0	378.0	16.0	19.0	●	
305.0	340.0	15.0	17.5	●		340.0	380.0	18.0	20.0	●	
305.0	349.0	20.0	22.0	●		340.0	380.0	20.0	20.0	●	
305.0	355.0	15.0	25.0	●		340.0	384.0	20.0	22.0	●	
305.0	362.0	19.0	28.5	●		340.0	400.0	28.0	30.0	●	
310.0	350.0	17.5	20.0	●		345.0	389.0	20.0	22.0	●	
310.0	350.0	18.0	20.0	●	●	345.0	395.0	20.0	25.0	●	
310.0	354.0	20.0	22.0	●		346.0	390.0	20.0	22.0	●	
310.0	355.0	24.0	22.5	●		348.0	380.0	16.0	16.0	●	
310.0	370.0	28.0	30.0	●		350.0	380.0	16.0	15.0	●	
314.0	355.0	20.0	20.5	●		350.0	390.0	15.0	20.0	●	
315.0	347.0	13.0	16.0	●		350.0	390.0	16.0	20.0	●	
315.0	355.0	18.0	20.0	●		350.0	390.0	18.0	20.0	●	
315.0	359.0	20.0	22.0	●		350.0	390.0	20.0	20.0	●	●
315.0	360.0	20.0	22.5		●	350.0	394.0	20.0	22.0	●	●
315.0	365.0	20.0	25.0	●		350.0	394.0	22.0	22.0	●	
315.0	380.0	29.0	32.5	●		350.0	405.0	20.0	27.5	●	
317.0	361.0	20.0	22.0	●	●	355.0	379.0	20.0	12.0	●	
320.0	350.0	15.0	15.0	●		355.0	385.0	16.0	15.0		●
320.0	355.0	16.0	17.5	●	●	355.0	394.0	20.0	19.5	●	
320.0	360.0	18.0	20.0	●	●	355.0	410.0	25.0	27.5		●
320.0	360.0	20.0	20.0	●	●	360.0	390.0	18.0	15.0	●	
320.0	364.0	20.0	22.0	●	●	360.0	400.0	16.0	20.0	●	
323.0	363.0	16.0	20.0	●		360.0	400.0	18.0	20.0	●	
325.0	365.0	16.0	20.0	●	●	360.0	400.0	20.0	20.0	●	
325.0	365.0	20.0	20.0	●		360.0	404.0	20.0	22.0	●	●
325.0	369.0	22.0	20.0	●		360.0	410.0	22.0	25.0	●	
325.0	369.0	20.0	22.0	●		362.0	400.0	20.0	19.0	●	
325.0	375.0	22.0	25.0		●	362.0	406.0	19.5	22.0	●	
328.0	372.0	20.2	22.0	●		362.0	406.0	20.0	22.0	●	
330.0	370.0	18.0	20.0	●		362.0	406.0	22.0	22.0	●	
330.0	370.0	20.0	20.0	●	●	363.0	418.0	20.0	27.5	●	
330.0	374.0	19.0	22.0	●		365.0	405.0	18.0	20.0	●	
330.0	374.0	20.0	22.0	●	●	365.0	409.0	20.0	22.0	●	●
330.0	374.0	22.0	22.0	●		370.0	410.0	15.0	20.0	●	
335.0	375.0	18.0	20.0	●		370.0	410.0	18.0	20.0		●
335.0	379.0	20.0	22.0	●	●	370.0	410.0	20.0	20.0	●	
335.0	400.0	35.0	32.5	●		370.0	414.0	19.0	22.0	●	●
338.0	382.0	20.0	22.0	●		370.0	414.0	20.0	22.0	●	●
340.0	370.0	15.0	15.0	●							
340.0	370.0	18.0	15.0	●							

These additional dimensions available on request.  
Please contact Trelleborg sealing solutions.



Dimensions				Type		Dimensions				Type	
d <sub>1</sub>	d <sub>2</sub>	b	f	TRJ	TRL	d <sub>1</sub>	d <sub>2</sub>	b	f	TRJ	TRL
370.0	414.0	25.0	22.0	●		410.0	450.0	20.0	20.0	●	
375.0	419.0	20.0	22.0	●		413.0	455.0	20.0	21.0	●	
375.0	419.0	22.2	22.0	●		415.0	445.0	20.0	15.0	●	
375.0	420.0	16.0	22.5	●		415.0	455.0	20.0	20.0	●	
378.0	428.0	18.5	25.0	●		415.0	459.0	20.0	22.0	●	
380.0	410.0	12.5	15.0	●		417.0	467.0	25.0	25.0	●	
380.0	420.0	15.0	20.0	●		420.0	460.0	18.0	20.0		●
380.0	420.0	15.0	20.0		●	420.0	460.0	19.0	20.0	●	
380.0	420.0	18.0	20.0	●	●	420.0	460.0	20.0	20.0	●	
380.0	420.0	20.0	20.0	●		420.0	470.0	20.0	25.0	●	
380.0	420.0	20.0	20.0	●		420.0	470.0	22.0	25.0	●	●
380.0	420.0	22.0	20.0	●		420.0	470.0	25.0	25.0	●	
380.0	424.0	20.0	22.0	●	●	430.0	470.0	20.0	20.0	●	
380.0	435.0	25.0	27.5	●		430.0	474.0	20.0	22.0	●	
380.0	438.0	23.0	29.0	●		430.0	480.0	20.0	25.0	●	
380.0	440.0	25.0	30.0	●		430.0	480.0	22.0	25.0	●	●
381.0	432.0	25.0	25.5	●		430.0	480.0	25.0	25.0	●	
384.0	414.0	15.0	15.0	●		430.0	490.0	25.0	30.0	●	
384.0	428.0	20.0	22.0		●	435.0	485.0	22.0	25.0	●	
385.0	430.0	25.0	22.5	●		435.0	485.0	30.0	25.0		●
385.0	438.0	32.0	26.5	●		437.0	487.0	19.8	25.0	●	
387.0	431.0	22.5	22.0	●	●	437.0	487.0	21.5	25.0	●	
390.0	420.0	14.0	15.0	●		440.0	469.0	12.5	14.5	●	
390.0	420.0	16.0	15.0	●		440.0	480.0	20.0	20.0	●	
390.0	430.0	18.0	20.0	●		440.0	490.0	20.0	25.0	●	
390.0	430.0	20.0	20.0	●		440.0	490.0	20.5	25.0	●	
390.0	434.0	19.2	22.0	●		440.0	490.0	22.0	25.0	●	●
390.0	434.0	20.0	22.0	●	●	440.0	490.0	25.0	25.0	●	
390.0	440.0	22.0	25.0		●	440.0	490.0	28.0	25.0		●
390.0	464.0	20.0	37.0		●	445.0	495.0	22.0	25.0	●	
395.0	430.0	18.0	17.5	●	●	446.0	486.0	16.0	20.0	●	●
395.0	431.0	18.0	18.0	●		447.0	497.0	22.0	25.0	●	
395.0	439.0	20.0	22.0	●	●	450.0	490.0	18.0	20.0		●
400.0	438.0	17.5	19.0	●		450.0	494.0	20.0	22.0	●	
400.0	440.0	14.0	20.0		●	450.0	500.0	20.0	25.0	●	
400.0	440.0	18.0	20.0	●		450.0	500.0	20.0	25.0		●
400.0	444.0	20.0	20.0	●	●	450.0	500.0	22.0	25.0	●	●
400.0	444.0	19.2	22.0	●		450.0	500.0	25.0	25.0	●	
400.0	444.0	20.0	22.0	●	●	454.0	500.0	18.0	23.0	●	
400.0	445.5	22.0	22.7	●		455.0	505.0	22.0	25.0		●
400.0	450.0	20.0	25.0	●		458.0	494.0	12.0	18.0	●	
400.0	450.0	22.0	25.0	●	●	460.0	500.0	18.0	20.0	●	
405.0	455.0	22.0	25.0	●							
410.0	450.0	18.0	20.0		●						

These additional dimensions available on request.  
Please contact Trelleborg sealing solutions.





Dimensions				Type		Dimensions				Type	
d <sub>1</sub>	d <sub>2</sub>	b	f	TRJ	TRL	d <sub>1</sub>	d <sub>2</sub>	b	f	TRJ	TRL
460.0	500.0	20.0	20.0	●		528.0	578.0	22.0	25.0		●
460.0	510.0	22.0	25.0	●	●	530.0	565.0	20.0	17.5	●	
460.0	510.0	25.0	25.0	●		530.0	566.0	18.0	18.0	●	
460.0	510.8	20.6	25.4	●		530.0	570.0	22.0	20.0	●	
460.0	510.8	25.4	25.4	●		530.0	580.0	20.0	25.0	●	
460.0	520.0	30.0	30.0	●		530.0	580.0	22.0	25.0	●	
467.0	510.0	20.0	21.5	●		530.0	580.0	25.0	25.0	●	
467.0	510.0	25.0	21.5		●	530.0	580.8	22.2	25.4	●	
470.0	520.0	22.0	25.0	●	●	533.0	577.0	25.0	22.0	●	
470.0	520.0	25.0	25.0	●		540.0	584.0	20.0	22.0	●	
474.0	514.0	20.0	20.0	●		540.0	590.0	22.0	25.0	●	●
475.0	530.0	18.0	27.5	●	●	540.0	590.0	25.0	25.0		●
475.0	530.0	20.0	27.5	●		542.0	578.0	18.0	18.0	●	
477.0	527.0	22.0	25.0		●	545.0	595.0	22.0	25.0	●	
480.0	520.0	16.0	20.0	●		550.0	600.0	22.0	25.0	●	●
480.0	520.0	20.0	20.0	●		550.0	610.0	25.0	30.0	●	
480.0	530.0	22.0	25.0	●	●	555.0	605.0	22.0	25.0		●
480.0	530.0	25.0	25.0	●		556.0	600.0	22.0	22.0	●	
482.0	530.0	20.0	24.0	●		558.0	589.0	19.0	15.5	●	
485.0	535.0	22.0	25.0	●		560.0	598.0	19.0	19.0	●	
490.0	540.0	22.0	25.0		●	560.0	610.0	20.0	25.0	●	
495.0	545.0	25.0	25.0		●	560.0	610.0	22.0	25.0	●	
497.0	538.0	20.0	20.5	●		570.0	620.0	22.0	25.0	●	●
500.0	540.0	20.0	20.0	●		570.0	620.0	25.0	25.0	●	
500.0	544.0	20.0	22.0	●		575.0	611.0	16.0	18.0	●	
500.0	550.0	22.0	25.0	●		575.0	625.0	22.0	25.0	●	
500.0	550.0	22.0	25.0	●	●	580.0	605.4	12.7	12.7	●	
503.0	552.0	20.0	24.5	●		580.0	615.0	20.0	17.5	●	
508.0	555.0	22.0	23.5	●		580.0	616.0	16.0	18.0	●	●
508.0	558.0	22.0	25.0	●		580.0	630.0	22.0	25.0	●	
508.0	558.0	25.0	25.0	●		580.0	630.0	34.0	25.0	●	
510.0	550.0	20.0	20.0	●		586.0	646.0	22.0	30.0	●	
510.0	554.0	20.0	22.0	●		590.0	640.0	20.0	25.0	●	
510.0	560.0	20.0	25.0	●		590.0	640.0	22.0	25.0	●	
510.0	560.0	22.0	25.0	●		596.0	646.0	22.0	25.0	●	
520.0	564.0	20.0	22.0	●		600.0	632.0	12.5	16.0	●	
520.0	570.0	19.0	25.0	●		600.0	640.0	20.0	20.0	●	
520.0	570.0	22.0	25.0	●		600.0	650.0	22.0	25.0	●	
520.0	570.0	25.0	25.0	●		600.0	650.0	30.0	25.0	●	
520.0	570.8	20.6	25.4	●		600.0	664.0	25.0	32.0		●
520.0	572.0	25.0	26.0	●		603.0	640.0	16.0	18.5	●	
525.0	575.0	22.0	25.0	●	●	604.0	640.0	18.0	18.0	●	
527.0	587.0	30.0	30.0	●							
527.0	587.0	38.0	30.0		●						

These additional dimensions available on request.  
Please contact Trelleborg sealing solutions.



Dimensions				Type	
d <sub>1</sub>	d <sub>2</sub>	b	f	TRJ	TRL
610.0	660.0	22.0	25.0	●	
614.0	659.0	20.0	22.5	●	
615.0	665.0	24.5	25.0	●	
615.0	679.0	24.5	32.0	●	
620.0	670.0	22.0	25.0	●	
620.0	684.0	25.0	32.0	●	●
625.0	689.0	25.0	32.0	●	
640.0	680.0	20.0	20.0		●
650.0	689.0	19.0	19.5	●	
650.0	690.0	20.0	20.0	●	
650.0	700.0	22.0	25.0		●
650.0	714.0	25.0	32.0	●	●
650.0	720.0	28.5	35.0		●
660.0	710.0	22.0	25.0	●	
660.0	724.0	25.0	32.0	●	
660.0	724.0	28.0	32.0		●
665.0	729.0	25.0	32.0	●	●
670.0	714.0	22.0	22.0		●
670.0	735.0	25.0	32.5	●	
680.0	730.0	20.0	25.0	●	
681.0	744.5	25.4	31.7	●	
685.0	749.0	25.0	32.0	●	
686.0	740.0	25.0	27.0	●	
700.0	764.0	25.0	32.0	●	●
710.0	760.0	20.0	25.0	●	
710.0	770.0	30.0	30.0	●	
710.0	774.0	25.0	32.0	●	●
715.0	779.0	25.0	32.0	●	
720.0	760.0	18.0	20.0		●
730.0	794.0	25.0	32.0	●	●
735.0	793.0	25.0	29.0		●
740.0	780.0	18.0	20.0		●
740.0	790.0	20.0	25.0	●	
744.0	794.0	25.0	25.0		●
744.0	808.0	25.0	32.0	●	
750.0	780.0	18.0	15.0	●	
750.0	789.0	19.0	19.5	●	
750.0	810.0	30.0	30.0	●	
750.0	814.0	25.0	32.0	●	
760.0	800.0	20.0	20.0	●	
760.0	820.0	30.0	30.0	●	
762.0	803.0	25.4	20.5		●
762.0	825.5	25.4	31.7	●	
765.0	825.0	26.0	30.0	●	

Dimensions				Type	
d <sub>1</sub>	d <sub>2</sub>	b	f	TRJ	TRL
770.0	845.0	27.5	37.5		●
775.0	839.0	25.0	32.0	●	
775.0	839.0	31.0	32.0		●
777.0	841.0	25.0	32.0	●	
780.0	820.0	18.0	20.0	●	●
780.0	844.0	25.0	32.0	●	
786.0	836.0	25.0	25.0	●	
790.0	850.0	30.0	30.0	●	
790.0	854.0	25.0	32.0	●	
800.0	860.0	30.0	30.0	●	
800.0	864.0	25.0	32.0	●	●
800.0	870.0	30.0	35.0	●	
810.0	860.0	25.0	25.0	●	
810.0	870.0	25.0	30.0	●	
810.0	874.0	25.0	32.0		●
820.0	884.0	25.0	32.0	●	
832.0	870.0	19.0	19.0	●	
840.0	904.0	25.0	32.0	●	
850.0	914.0	25.0	32.0	●	●
860.0	920.0	25.0	30.0	●	
860.0	924.0	25.0	32.0		●
870.0	934.0	25.0	32.0		●
880.0	944.0	25.0	32.0	●	
889.0	970.0	21.0	40.5		●
890.0	954.0	25.0	32.0	●	
898.0	960.0	30.0	31.0		●
900.0	960.0	30.0	30.0	●	
910.0	966.0	25.0	28.0		●
920.0	984.0	25.0	32.0	●	
935.0	999.0	25.0	32.0	●	
940.0	995.0	25.0	27.5		●
940.0	1,000.0	30.0	30.0	●	
950.0	1,000.0	25.0	25.0	●	
950.0	1,010.0	30.0	30.0	●	
960.0	1,024.0	25.0	32.0	●	
1,000.0	1,050.0	25.0	25.0		●
1,000.0	1,064.0	25.0	32.0	●	
1,020.0	1,084.0	25.0	32.0	●	
1,055.0	1,119.0	25.0	32.0		●
1,060.0	1,124.0	25.0	32.0		●
1,150.0	1,214.0	25.0	32.0	●	
1,220.0	1,284.0	25.0	32.0		●

These additional dimensions available on request.  
Please contact Trelleborg sealing solutions.



Dimensions				Type	
d <sub>1</sub>	d <sub>2</sub>	b	f	TRJ	TRL
1,250.0	1,300.0	22.0	25.0		●
1,250.0	1,314.0	25.0	32.0	●	
1,320.0	1,398.0	32.0	39.0	●	
1,320.0	1,420.0	49.0	50.0		●
1,580.0	1,644.0	25.0	32.0		●
1,790.0	1,854.0	24.7	32.0		●
1,890.0	1,954.0	25.0	32.0		●

These additional dimensions available on request.  
Please contact Trelleborg sealing solutions.