

Cassette Seal





A large grid of graph paper for taking notes, consisting of 30 columns and 40 rows.



■ Cassette Seal

■ General Description

The Cassette Seal has been developed to meet the ever-increasing requirements of long service life, high functional reliability, environmental safety, simple handling and superior total economy. Cassette Seals are fully enclosed seals with an integrated sealing system, that perform the function of oil seal, wear sleeve and dust protection in one unit. No extra components such as shaft sleeves or dirt protection are needed.

Unique to all the Trelleborg Sealing Solutions Cassette Seals is that the sealing lip is fixed on the stationary part of the hardware. Because of this the sealing force is constant, independent of the rotary speed. Cassette Seals consist of several individual features working together, built into one unit and for this reason they are called "Systems".

Cassette Seals are originally designed at FORSHEDA AB in Sweden under the trade name STEFA.

■ System 500

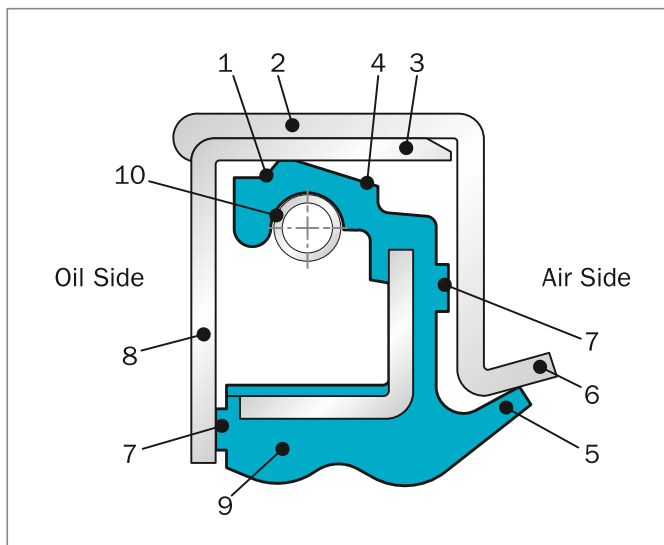

Figure 50: System 500

System 500, the original Unitized Wheel Hub Seal for heavy-duty vehicles, is designed for rotating hubs. The inner section of the System 500 is secured against the shaft. The outer section, press fitted into the wheel hub, rotates together with the hub around the inner section, creating a completely enclosed seal. Dirt and water, the major enemies of hub seals, are effectively kept at distance, whilst the lubrication of the rubber lip remains intact. This decreases friction and increases seal life accordingly.

THE MAIN FEATURES OF THE SYSTEM 500 ARE:

- The sealing (1) element is non-rotating, which means that the radial force is kept unchanged at various speeds.
- The sealing surface (2) is in close contact with the wheel hub, which gives an excellent heat transfer.
- The structure of the sealing counterface (3) has been chosen after several thousands of test hours. The position of the sealing lip ensures best lubrication.
- The sealing lip (4) normally has bi-directional TURBO-pattern (see page 122).
- Integral prelubricated dust-sealing (5) functions.
- The protruding conical part (6) of the case deflects heavier particles due to the centrifugal force.
- The excluding lip (5) protects against water splash and finer particles.
- Molded distance lugs (7) automatically locate the sealing element in the right position.
- The lugs (7) are spaced and dimensioned to ensure the sealing lip has adequate lubrication.
- The inner case (8) also protects the sealing lip from direct oil spray caused by taper roller bearings.

The robust ribs (9) give:

- a firm seat on the shaft
- a smooth sliding during installation
- a positive static seal even if one of the ribs is located on a defective shaft surface
- The compression spring (10) maintains the radial force. The initial force exerted by the sealing element will in some applications reduce due to aging of the rubber exposed to heat, load or chemical action.
- For such applications where the seal is exposed to dirty environment, i.e. off road use, the System 500 can be equipped with an additional specially developed dirt protection, the HRV seal.
- In cases where the space does not allow the use of the HRV seal, the System 500HD, a derivative of System 2000 (with additional dust lip), can be used. It has the same outside dimensions, but an extra dust lip inside. Since the casing is identical to System 500 it is readily available in the same sizes. Please contact your local Trelleborg Sealing Solutions marketing company for more details.



■ System 2000

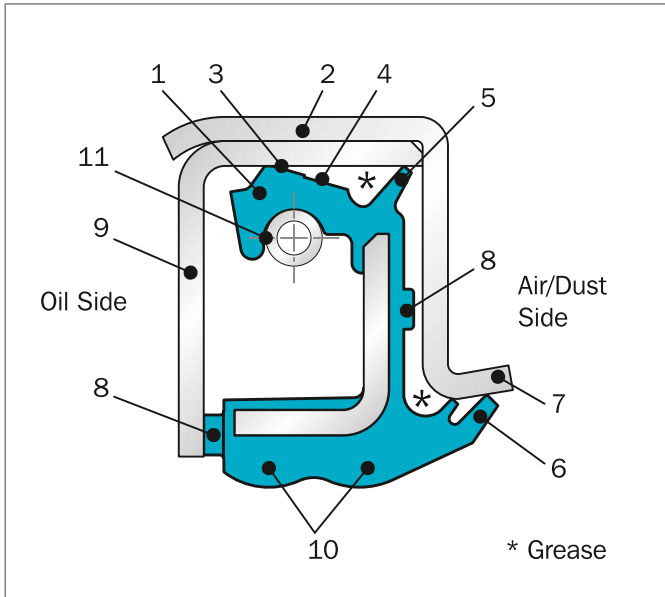

Figure 51: System 2000

System 2000 is a Unitized Cassette Seal suitable for wheel hubs working in heavily polluted environments, like agricultural and construction vehicles.

Like for System 500 and System 3000, the inner section of the System 2000 is secured against the shaft and is rubberized, while the outer section is press fitted into the bore, and rotates together with the hub around the inner section, creating a completely enclosed seal; the outer diameter can be provided by a sealing paint to increase the static sealing functionality in critical conditions, for example when the bore surface is porous or scratched.

Dirt and water, the major enemies of the off road hub seals, are effectively kept at distance thanks to the many sealing lips, whilst the lubrication of the rubber lip remains intact and is assured by the packing grease. This decreases friction and increases seal life accordingly.

System 2000 is limited in speed compared to System 500, due to the higher number of internal dust sealing lips.

MAIN FEATURES OF SYSTEM 2000

- The sealing (1) lip, if the Cassette Seal is assembled in rotating wheel hubs, is non-rotating and this feature allows the radial force to be kept stable at various speeds.
- The outer sealing surface (2) is in close contact with the wheel hub, which gives an excellent heat transfer.
- The structure of the sealing counter face (3) has been chosen after several thousand test hours. The position of the sealing lip ensures best lubrication.
- The sealing lip (4) normally has a bi-directional TURBO pattern engraved, that improves the sealing capability.
- The internal dust-sealing lip (5), located just behind the primary sealing lip, creates a supplementary grease lubrication chamber near the sealing edge and guarantees an extra barrier against dirt/pollution/water ingress
- External double dust-sealing lips (6) with tailored progressive contact load, provides an optimized protection against contaminants while keeping friction low.
- The protruding conical part (7) of the case deflects heavier particles thanks to the centrifugal force.
- Molded distance lugs (8) automatically locate the sealing element in the right position during assembly; they are spaced and dimensioned to ensure adequate lubrication to the sealing lip.
- The inner case (9) protects the sealing lip from direct oil spray caused by tapered roller bearings.
- The inner diameter is provided by two robust ribs (10) that provide a smooth sliding during installation and a positive static seal on scratched shaft surfaces.
- The compression spring (11) energizes the sealing lip keeping a constant radial force during life time.

For such applications where the seal is exposed to extremely dirty and wet environments, i.e. heavy-duty tractors, the System 2000 can be also equipped with an additional specially developed HRV seal lip, that looks like an external V-Ring lip sliding against the shaft on the dust side.



■ System 3000

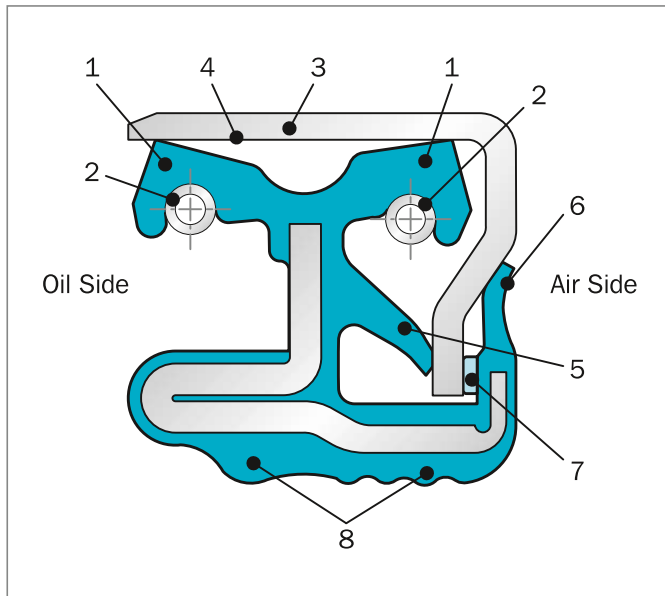

Figure 52: System 3000

System 3000 is a specifically designed Cassette Seal for rotating hubs working in very heavily polluted environments, like tractors operating in rice fields, forestry machinery and dumper trucks operating in quarries and mines.

The design of System 3000 has been specifically developed for long term sealing effectiveness; the internal labyrinth lips have been optimized for friction reduction and flexibility.

Mud-box tests realized in laboratories according to the most demanding customer specifications are showing a significant improvement in life time performance compared to other Cassette Seals. System 3000 has excellent ability to seal in oil while excluding water, dust and mud.

Thanks to its optimized design, System 3000 keeps the same ability to sustain eccentricities, over-pressure and shaft misalignment as standard Rotary Oil Seals.

MAIN FEATURES OF SYSTEM 3000

- System 3000 has tandem energized sealing lips (1) that are stationary against the rotating hub; this feature lets the two lips effectively seal oil and contaminants and are effectively lubricated by the intermediate grease chamber.
- The twin compression springs (2) energize the tandem sealing lips, keeping a constant radial force during life time.
- The outer sealing surface (3) is in close contact with the wheel hub, which gives excellent heat transfer.
- The structure of the sealing counter face (4) has been chosen after several thousand test hours. The position of the sealing lip ensures optimal lubrication.
- Tailored internal axial dust sealing lip (5), has a steady contact with metal counter-face even in case of eccentricity or axial play. It creates a double labyrinth chamber that effectively traps any pollution.
- An external dust-sealing lip (6), is working again with an axial load minimizing in this way friction and wear, and provides the first barrier against contaminants.
- Molded distance lugs (7) locate the sealing element in the right position during assembly of the shaft.
- The inner diameter combines a large rib and multiple smaller ribs (8) in order to provide smooth sliding during installation and secure sealing against scratched shafts.

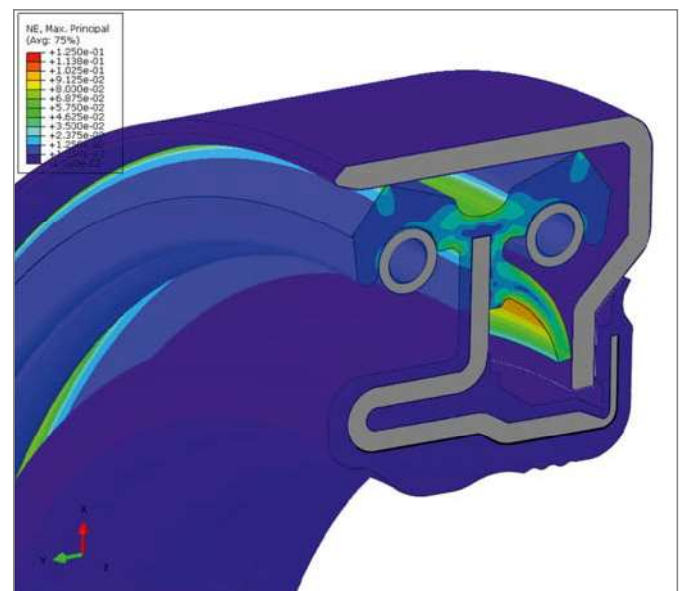

Figure 53: Friction optimization through FEA



■ System 5000

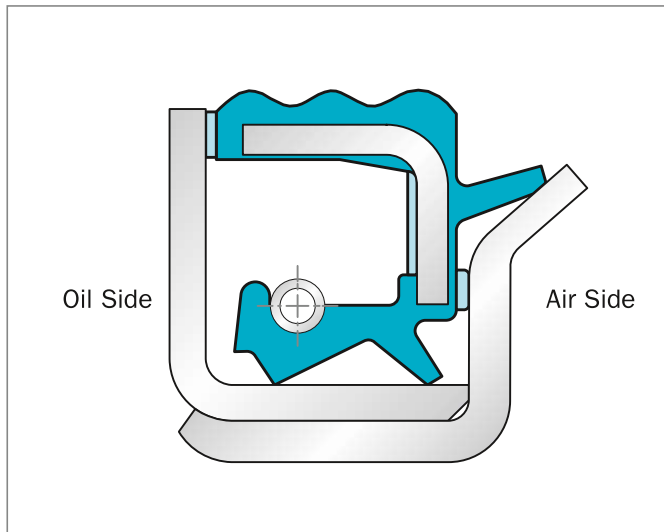

Figure 54: System 5000

System 5000 is, like System 500 and System 3000, a fully enclosed seal, but is designed for rotating shafts. The System 5000 has the same features but the design has been inverted, i.e. the sealing element is fixed in the stationary housing and the casing components rotate with the shaft.

System 5000 is used to prevent oil from leaking out of a bearing housing, i.e. a differential pinion housing for rear axles on trucks, and at the same time preventing road dirt, salt and water splashes from entering.

The design is compact and integrates the necessary shaft counterface as well as providing dirt exclusion. The dirt exclusion function consists of two rubber lips, one axial and one radial, the space between these filled with grease, and the rotating seal case, which acts as an effective deflector due to the centrifugal force.

TURBO-PATTERN · HYDRODYNAMIC SEALING AIDS

TURBO is the Trelleborg Sealing Solutions designation of a range of hydrodynamic sealing aids supporting the sealing function. The hydrodynamic sealing aids are located on the air side of the main sealing lip in the form of ribs or other geometrical shapes. Optimum sealing conditions are attained when a thin film of lubricant is formed so that the lip does not come in contact with the sealing counterface. Such conditions are created by the TURBO-pattern, which brings about a pumping effect. The pumping effect starts at relatively low shaft speed, and is understood as the capacity of the seal lip to pump the media to be sealed back from the air side to the media side.

In order to avoid leakage at standstill or low speed, the TURBO-pattern includes a static edge, which provides a continuous contact line against the counterface. The frictional loss of the seals provided with TURBO-pattern is significantly lower than that caused by seals without hydrodynamic sealing aids. A lower friction does also allow higher-rotary speeds, or provides longer service life.

The Turbo pattern is available in three versions: bi-directional, left hand or right-hand rotation. The standard is bi-directional as most applications have alternating movement of the hub or shaft. If an application has rotation in one direction only, the corresponding left- or right-hand type can be specified. The direction of rotation is always defined as seen from the air side.



■ System CLS 1500

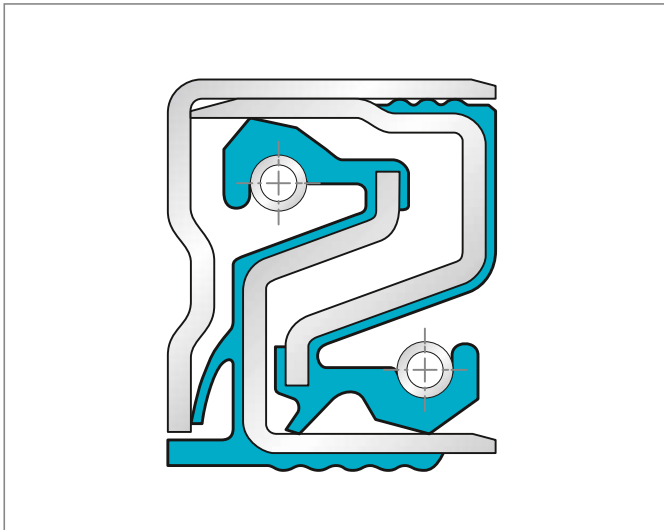

Figure 55: System CLS 1500

CLS 1500 was specially designed for applications in agriculture, vehicle axles, hubs and industrial gearboxes. Its design provides more protection against pollution due to an enlarged space for the grease between the sealing lips, which have also been improved in order to reduce friction and wear.

In the course of this, the oil-side lip based on worldclass standards is open to the oil and thus better cooled.

Design is not only characterized by excellent static sealing and optimized heat dissipation, but also by lower production costs, since crimping and grinding are not necessary.

During assembly, a double metal frame that adds further stability protects the seal from deformation.

Various endurance tests have proven that System CLS 1500 causes no measurable leakage in hot oil tests or any oil contamination in slurry tests. For that reason, System CLS 1500 is a pioneer in enhancing performance in heavy-duty applications.

CLS 1500 is a customized product and will be designed to specifically meet application requirements. Please contact your local Trelleborg Sealing Solutions marketing company for more information.

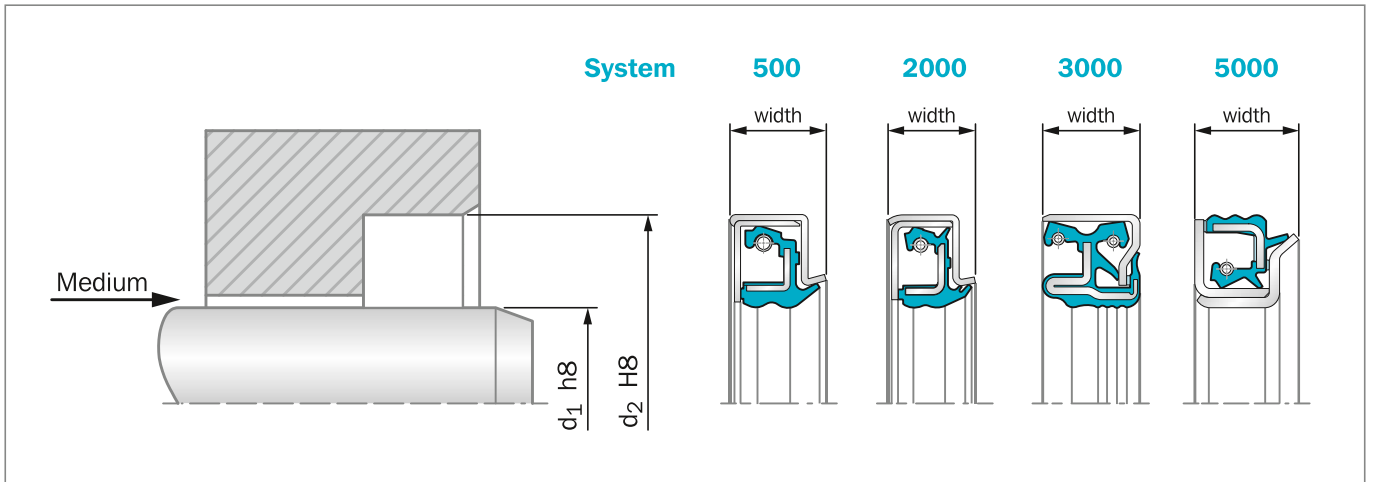

Figure 56: Installation Drawing

Table 40: Standard Dimensions

ID d ₁	OD d ₂	Width	System 500			System 2000		System 3000		System 5000		
			NBR	HNBR	FKM	NBR	HNBR	NBR	HNBR	NBR	HNBR	FKM
85	140	17								•	•	•
90	130	17	•	•	•							
100	130	17	•	•	•							
100	140	17	•	•	•							
110	140	17	•	•	•							
111	146	17	•	•	•							
120	160	17	•	•	•							
125	160	17	•	•	•							
128	164	17	•	•	•							
130	160	17	•	•	•			•	•			
130	170	17	•	•	•							
135	165	17	•	•	•							
140	170	17	•	•	•							
143.3	190.5	16				•	•					
145	175	17	•	•	•							
149.9	176	16	•	•								
150	180	17						•	•			
155	190	17	•	•	•							
158	188	16					•					
160	191.5	16.5								•		
160	196	17	•	•		•	•					
178	205	17	•	•	•							
178	207.7	16.5						•	•			
187	230	17	•	•	•							



ID d ₁	OD d ₂	Width	System 500			System 2000		System 3000		System 5000		
			NBR	HNBR	FKM	NBR	HNBR	NBR	HNBR	NBR	HNBR	FKM
190	230	17	●	●	●			●				
250	290	17	●	●								
320	360	19	●	●								

Table 41: Materials

Standard Material*	TSS Material Code	Standard Metal Case	Standard Spring
NBR (70 Shore A)	4N063	Carbon steel	Carbon steel
HNBR (75 Shore A)	4H063	Carbon steel	Carbon steel
FKM (75 Shore A)	4V063	Carbon steel	Carbon steel

* Special grades and other materials on request.

ORDERING EXAMPLE

Due to various combinations (HRV-additional dirt seal + coating), please contact your local Trelleborg Sealing Solutions marketing company when ordering Cassette Seals.



■ Materials

METAL CASE

The cases are normally stamped of cold rolled steel sheet, EN 10 130 - Fe P04. The high demands on the metal cases, such as high surface finish, free from scratches, call for production using special tools.

COMPRESSION SPRING

For the spring, spring steel SS14 1774 - DIN 17223 - is normally employed. If resistance to corrosion is required, stainless steel SS 14 2331 - DIN 1.4301 is used.

SEALING ELEMENT

The material of the sealing element must be selected according to the working conditions of the seal and the environmental conditions.

Some of the requirements associated with environmental considerations are:

- good chemical resistance
- good resistance to heat and low temperature
- good resistance to ozone and weathering

The functional demands include:

- high resistance to wear
- low friction
- low compression set
- good elasticity

In addition, cost considerations make ease of processing a desirable feature.

No material is available today that satisfies all these requirements. The choice of material is therefore always a compromise between the relative significance of the factors involved.

Trelleborg Sealing Solutions has succeeded in developing a Nitrile Rubber compound (NBR), which exhibits good all-round properties, and for this reason is the compound most commonly used.

The materials normally used for the sealing element are: Nitrile Rubber (NBR), Hydrogenated Nitrile Rubber (HNBR) and Fluorinated Elastomers (FKM).

The additional dirt seal is normally made of Nitrile Rubber. Nitrile Rubber is the basis material for Cassette Seals, as it covers most standard application requirements for general oil- and grease resistance. It is from function and cost aspects the best choice when temperature is not excessively high. Nitrile can be used up to +125 °C in non-aggressive oils. However for long term use, or in aggressive oils, service temperature is reduced to +80 °C.

Nitrile generally has good mechanical properties and the material used for Cassette Seals is optimized for best heat and abrasion resistance.

Hydrogenated Nitrile Rubber is a further development of NBR, where the chemical double bonds in the polymer molecules are saturated with hydrogen. Since the double bonds of NBR are sensitive to heat and ozone, the HNBR will be superior to NBR in heat, ozone and weather resistance. It can generally be used up to +150 °C in non-aggressive media, however for long term use maximum service temperature is +120 °C.

The HNBR for the Cassette Seal is fully saturated and thus well suited for use in aggressive oils. The temperature should however be limited at +120 °C. As saturated HNBR cannot be vulcanized with sulfur, the material has resistance to most hypoid oils up to about +120 °C for long term use.

Low friction and high abrasion resistance are additional typical features.

Fluorinated elastomers give peak performance regarding heat and chemical resistance. They can be used up to +200 °C for long term use and are generally very resistant to oil, grease and fuels. Their ozone and weather resistance is outstanding.

Mechanical and low temperature properties are however lower compared to Nitrile. Thus Fluoroelastomers should be considered only when the material properties are fully used. Some oil additives like amines and high pH-values may damage Fluoroelastomers when used at high temperatures.

TEMPERATURE RESISTANCE

Increasing temperature accelerates the aging of rubber, the elongation decreases, and the compression set increases and finally the material becomes hard and brittle. Cracks at the sealing edge are a typical indication that the seal has been exposed to excessively high temperature. The aging of the rubber has appreciable significance on the useful life of the seal. It can generally be said that a temperature increase of +10 °C (in air) will half the theoretical useful life of the rubber.



Low temperatures are generally not a big problem since the seals themselves generate heat by friction when rubbing against another surface. If the seal has been chilled down, its original properties will return as soon as it is warmed up again. Some leakage may however arise during the start-up phase, before the rubber material is softened by friction heat.

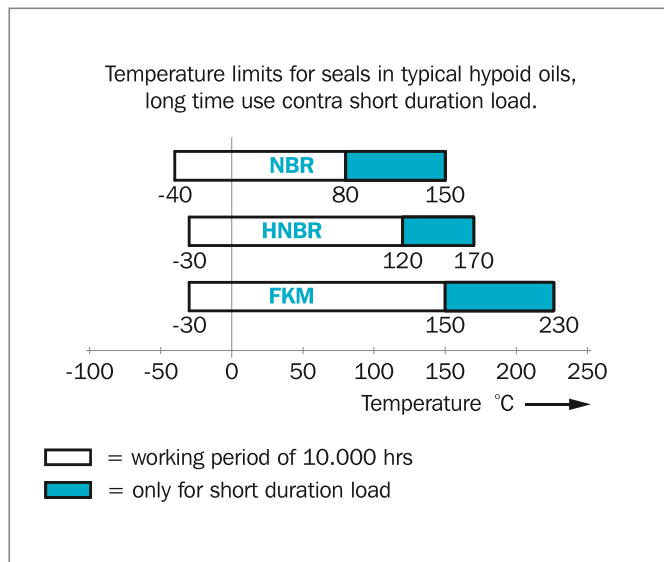

Figure 57: Temperature recommendations in typical hypoid oils

The temperature limits for the standard materials in hypoid oils are illustrated in Figure 57. They should only be regarded as approximate, since the oil type and the time of exposure also affects the materials. The temperature ranges within the shaded areas in the illustrations are temperatures that can be allowed only for certain periods of time. The higher the temperature, the shorter the period of time. At low temperatures, time has no influence on aging.

However, seals are not often working in air as the only media. Temperature limits in combination with other oils and media can be obtained from your local Trelleborg Sealing Solutions marketing company.

OIL RESISTANCE

Innumerable types of oils are available on the market and each of these has a different effect on the rubber. In addition, a given type of oil from a different manufacturer may have a different influence.

The additives in the oil generally affect the rubber. This is the case with hypoid oil, which contains sulfur. Since sulfur is used as a vulcanizing agent for Nitrile Rubber, the sulfur additive in the oil acts as a vulcanizing agent at temperatures above +80 °C. As a result of this secondary curing, Nitrile rubber will rapidly become hard and brittle. Hydrogenated Nitrile and

Fluorinated rubbers, which are not vulcanized with sulfur, can therefore be used for this type of oil, even though the operating temperature may not require these.

Oxidized oils represent another example illustrating the difficulty of tabulating the oil resistance of rubber materials. These oils are oxidized during operation and their properties will therefore change substantially.

Due to the above, no detailed information is given about resistance to certain types of oils. In case of questions or doubt, it is advisable to contact your local Trelleborg Sealing Solutions marketing company who have access to the many years of in-house testing. Additional testing can be carried out in specific oil types provided a sufficient sample is available.

CHEMICAL RESISTANCE

Since the Cassette seals are normally exposed to oil or grease, and not other chemicals, tables for chemical resistance to different media are not included. For guidelines about chemical resistance, please see the Radial Oil Seals chapter in this catalog on page 35 or contact your local Trelleborg Sealing Solutions marketing company.

Application

SYSTEM 500, 2000, 3000, 5000 AND CSL 1500

For the System 500, 2000, 3000, 5000 and CSL 1500, requirements on the shaft finish and hardness are less stringent in comparison with traditional radial shaft seals. A simple fine turning operation gives an adequate surface on the shaft as well as for the housing bore. Diameter tolerances and finish values are shown in Figure 58 and Figure 59.

As the sealing elements have built in counterfaces of their own, no wear on the shaft itself will occur and consequently no hardening of the shaft is necessary.

Suitable lead in chamfers facilitate the installation of the seal.

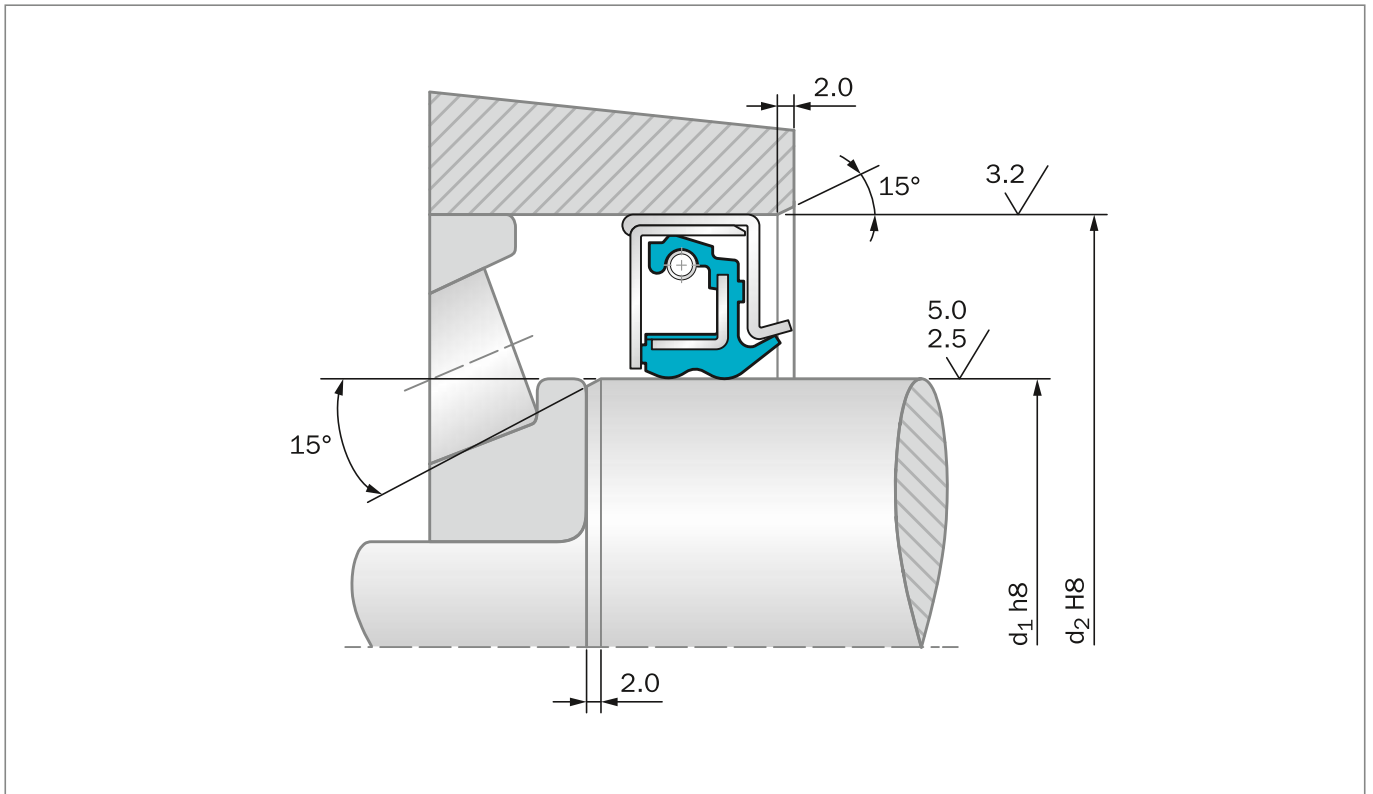

Figure 58: System 500 in wheel hub application (similar for System 2000 and System 3000)

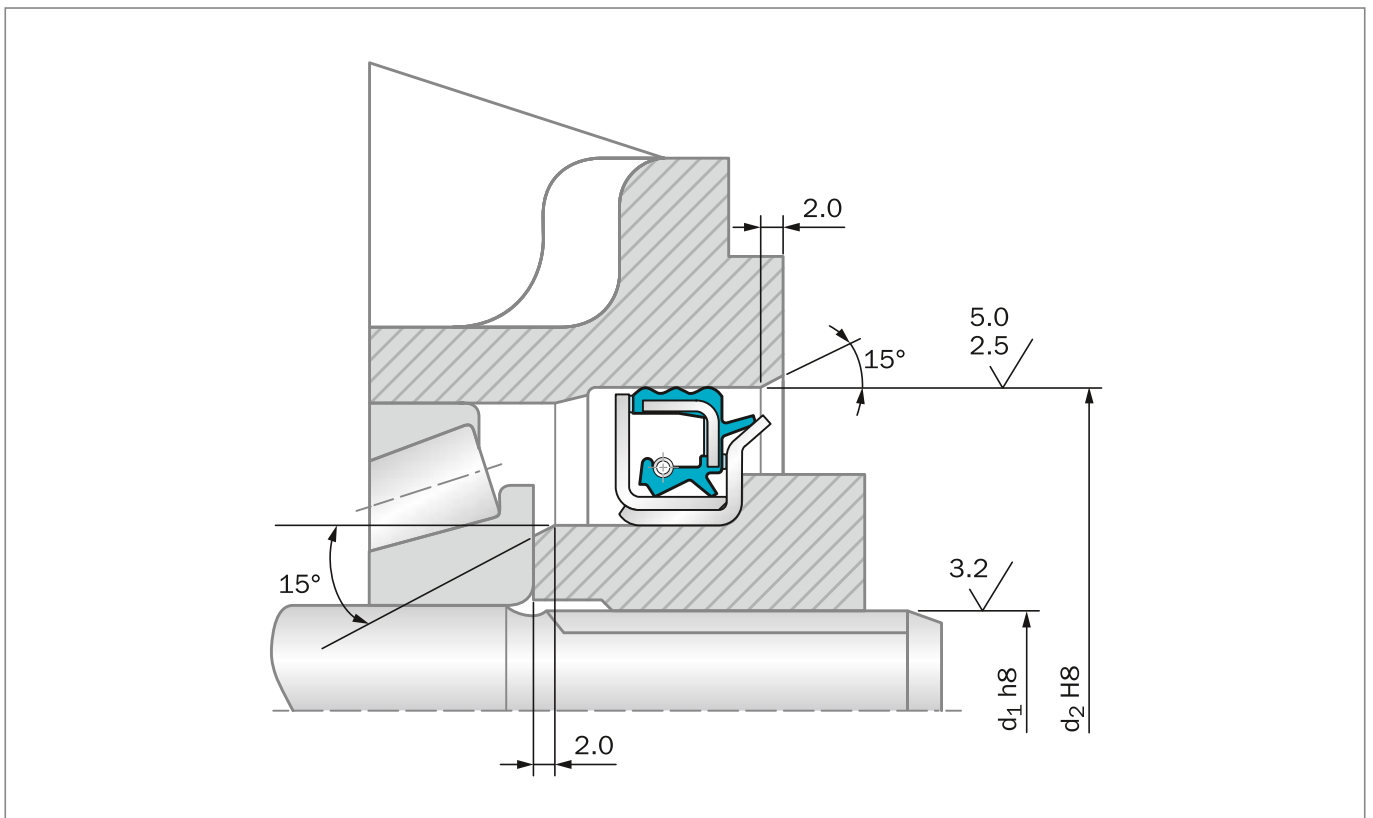

Figure 59: System 5000 in pinion application



SHAFT RUN-OUT

Shaft run-out should as far as possible be avoided or kept to a minimum. At higher speeds, there is a risk that the inertia of the sealing lip prevents it from following shaft movement. The seal must be located next to the bearing and bearing play must be maintained at the lowest possible value.

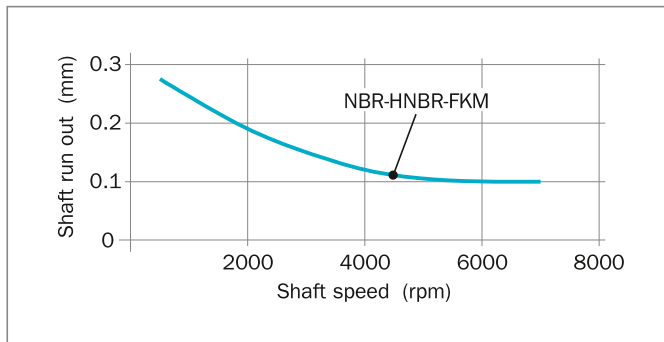

Figure 60: Permissible run-out of the shaft

ECCENTRICITY

Eccentricity between shaft and housing bore centers should be avoided in order to eliminate unilateral load on the lip.

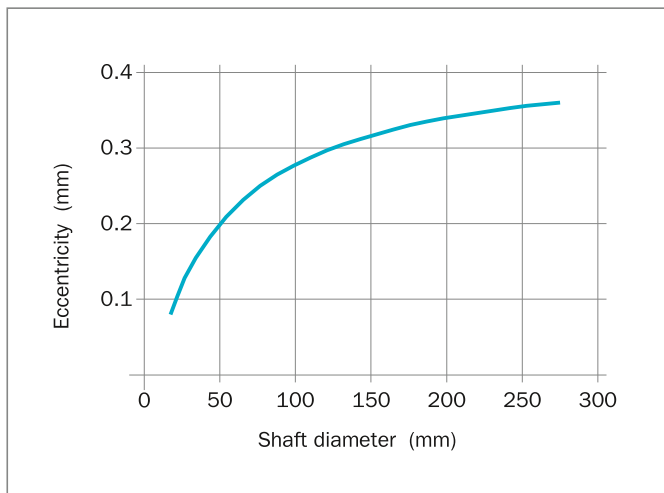

Figure 61: Permissible eccentricity

AXIAL MOVEMENT

Axial movement, including what can be considered as normal bearing play, should be within ± 0.1 mm. The Cassette Seal will function at larger movements, however this may cause larger wear on support lugs and result in shorter lifetime.

PRESSURE

Any difference in pressure from one side of the seal to the other should be avoided. Since the seal is developed for ventilated applications, a pressure difference will in the end lead to decreased lifetime or leakage. In some applications, a pressure difference up to 0.05 MPa could be accepted, but tests should be carried out for each case.

SPEED

The permissible speed of rotation at the sealing point for the various seal designs stated below, assumes normal running conditions, e.g. oil retention and no pressure differential across the seal.

Table 42: Max Surface Speed

Type of Seal	max. Surface Speed (m/s)
System 500	10
System 2000	5
System 3000	4
System 5000	15
CLS 1500	4

START/OPERATING TORQUE

Due to transferred assembly forces inside the Cassette Seal, the Cassette Seal absorbs higher torque than a standard radial seal. See the Installation section on page 132.

HRV - ADDITIONAL DIRT SEAL

The HRV seal is an all rubber seal. It is designed for use as a complementary seal for the System 500 and 2000 in dirty applications such as off-road. The main sealing is against small particles such as dust, but also dirt and splash. Since the sealing action is axial, it can absorb some axial displacement.

The HRV seal is bonded directly to the outer case of the cassette. The design is similar to the FORSHEDA V-Ring with a body and a flexible conical shaped sealing lip with an integral resilient "hinge" (see Figure 62).

The HRV seal rotates, due to the outer case being press fitted into the bore, and seals axially against a stationary counterface. During rotation the sealing lip rubs against the counterface under a contact pressure calculated to achieve sealing function. The HRV seal also operates as a deflector ring, and its centrifugal action contributes to good sealing.



Due to the centrifugal force, the contact pressure of the lip decreases with increase in speed. The contact pressure also varies with the fitted width.

The counterface for the HRV seal can consist of a suitable surface on the existing hardware or a steel casing adapted to suit the specification for the seal counterface.

The HRV seal:

- seals against outer media like dirt and dust
- has a deflecting function due to the centrifugal force

The requirements on the counterface against which the sealing lip works are rather low. They are more or less determined by the media to be sealed. A finish-turned, polished surface with a surface roughness of Ra 1.6 to 2.0 μm is normally adequate. For sealing against liquid and dirt, Ra 0.8 to 1.6 μm is recommended. However, the character of the surface is of greater importance than the actual surface roughness value. For turned surfaces, it is recommended to buff the surface with fine emery cloth to remove any sharp peaks, which could tear the rubber surface apart and destroy the sealing function, shortening seal life time.

It is also necessary to ensure that the counterface is perpendicular to the shaft, flat and free from scratch marks and other damage within the sealing area. This is especially important when sealing fluids and fine particles.

To achieve the full effect of the deflector action, the HRV seal should be designed in a relatively open space.

The fitted width dimension will be stated on the corresponding product drawing.

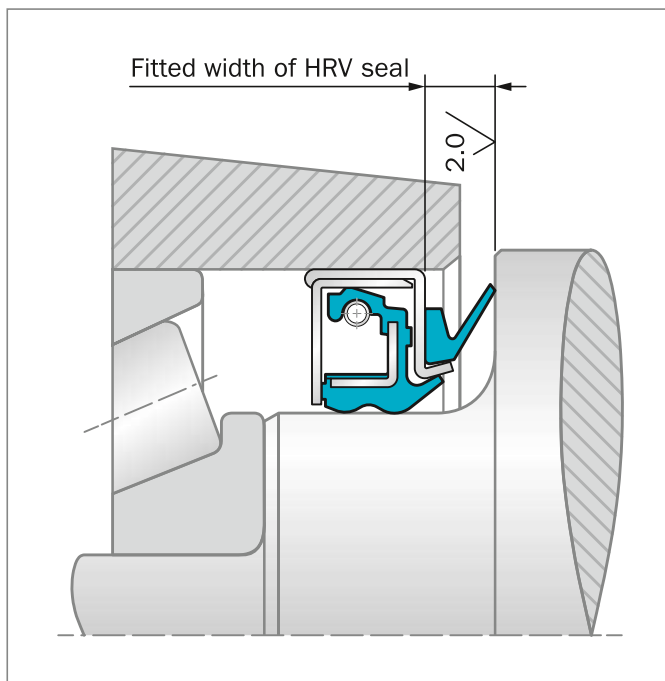

Figure 62: System 500 with HRV seal

■ Installation

As the Cassette Seal incorporates all functions of a seal, shaft counterface and dust protector, there is no need for extra components such as exchangeable shaft sleeves or dirt protection.

This means fewer parts to stock and handle.

When handling and fitting traditional shaft seals there is always a risk of damaging the shaft surface or sealing lips and of improper installation. As the Cassette Seal is fully enclosed, the vital sealing components cannot be touched or damaged during the installation.

SYSTEM 500, 2000, 3000 AND CSL 1500

System 500, 2000, 3000 and CSL 1500 Cassette Seal designs require a high assembly force to push the cassette inside the bore compared with the force needed to push the shaft inside the cassette. As such, the seals must first be assembled in the bore, with the shaft inserted afterwards.

Trelleborg Sealing Solutions recommends following this assembly procedure:

- Ensure the inner surface of the bore and any lead-in chamfers are in accordance with technical specifications and free from any dirt, burrs or scratches.
- Insert the Cassette Seal into the bore using a jig that only makes contact with the metal face of the cassette. Ensure that it does not touch the rubber. Only use a hydraulic piston guided with proper concentricity to the hub. Do not use a hammer or other tool to insert the Cassette Seal.
- The Cassette Seal orientation is indicated by "oil side" or "air side" marked on the seal. Once installed, ensure that the metal face is correctly oriented within the bore.
- Apply pre-lubricating media to the inner rubber surface of the seal. Never use oil or grease as they may reduce the stability of the Cassette Seal on the shaft. If the Cassette Seal is fitted with an optional HRV axial lip, then apply grease to the HRV.
- Insert the shaft or spindle inside the Cassette Seal. The shaft must be driven with proper concentricity to avoid damage. It is recommended to use a hydraulic piston – never use a hammer.

If this procedure is not followed, the Cassette Seal may not function correctly. If this procedure is not possible, contact your local Trelleborg Sealing Solutions marketing company to evaluate alternative assembly procedures.



During the start-up phase with the new Cassette Seal, some leakage of grease and smoke formation may be observed. This is a result of the generation of frictional heat between the metal case and internal rubber support lugs, and does not influence the function and service life of the seal.

When repairing or replacing a Cassette Seal, always use a new seal.

SYSTEM 5000

The System 5000 seal must be installed onto a shaft or a sleeve by a special assembly tool. The seal shall be oriented with the side marked "oil side" facing the inside of the gearbox. The shaft must then be assembled so the oil side of the seal is entering the housing bore.

If the shaft is hollow, the assembly tool should be designed with a guiding column.

For pinion applications on trucks, when a separate end carrier is used, the seal is simply pressed onto the end carrier in a first step of assembling. The end carrier is then entering the splines on the pinion shaft and then a locking nut is used to drive the end carrier and the seal into the right position.

The force required to assemble a System 5000 seal onto the shaft is between 20 to 50 kN, while assembly into the housing bore requires about 1.0 kN. The value of assembly force depends on the surface structure for shaft respecting the housing bore as well as the tolerances. It is recommended to oil the outer rubber covered surface of the seal and also the housing bore to decrease the force necessary for assembly.

During the start-up phase, eventually some leakage of grease and smoke formation may occur. This is a result of the generation of frictional heat between the metal cases and the support lugs of rubber, and does not influence the function and service life of the seal.

If the seal is jammed or damaged in some way during installation, the seal must be replaced before start up.

If the construction is disassembled for any reason, a new seal should be installed.

Further instructions for assembling can be found on separate assembly instruction sheets available from your local Trelleborg Sealing Solutions marketing company.

DISMANTLING AND REPLACEMENT

As all the necessary functions are integrated in the Cassette Seal the complete sealing arrangement is renewed. The shaft to be sealed is unaffected by wear and once it has been cleaned and possible corrosion and dirt have been removed, a new seal can be fitted again.

The Cassette Seal may be provided with a sealant on the metal casing when it is installed into the housing. Take care that the sealant does not flow into the seal or is smeared onto the rubber surface, as this may impede the function of the seal. The sealant can reduce the risk of static leakage due to small imperfections on the surface.

STORAGE

As the service life of bearings and other machine parts depends on how well the seals perform, seals should be handled with caution. Unfavorable storage conditions or improper handling will most likely lead to a change of their physical properties. This can lead to a shortening of life, or failure, for example as a result of hardening or softening, cracking or other surface damages. These changes can be the result of one particular factor or a combination of factors, like oxygen, ozone, heat, light, moisture, solvents etc. Storing the seals under load can lead to permanent deformation of the elastomer. On the other hand, properly stored elastomer products retain their properties for several years.

As the sensitive sealing lips and counter faces are well protected inside the Cassette Seal casing, there is less risk of mechanical damages and influence of dirt and dust in comparison to many other seal types.

CLEANING

If cleaning of Cassette Seal is necessary, use a damp duster and allow the seals to dry off at room temperature.

Solvents, sharp-edged objects and abrasives should not be used.



■ Type APJ – Combined Oil Seal

GENERAL DESCRIPTION

The APJ seal is an assembly composed of a rotary oil seal and a wear sleeve; the rotary oil seal is designed to satisfy customer specifications in terms of shaft speed, pressure, temperature, axial play and chemical compatibility and usually includes supplementary labyrinths and grease packing to prevent contaminant ingress. The integrated wear sleeve has a surface mating with the rotary oil seal, that is properly machined by Trelleborg, removing the need for shaft hardening and grinding. The sleeve can be rubberized or provided by a static sealing coating on the interface with the shaft.

APPLICATION EXAMPLES

- Off-road wheel hubs
- Industrial transmissions
- Robot gearboxes
- Food and chemical mixers

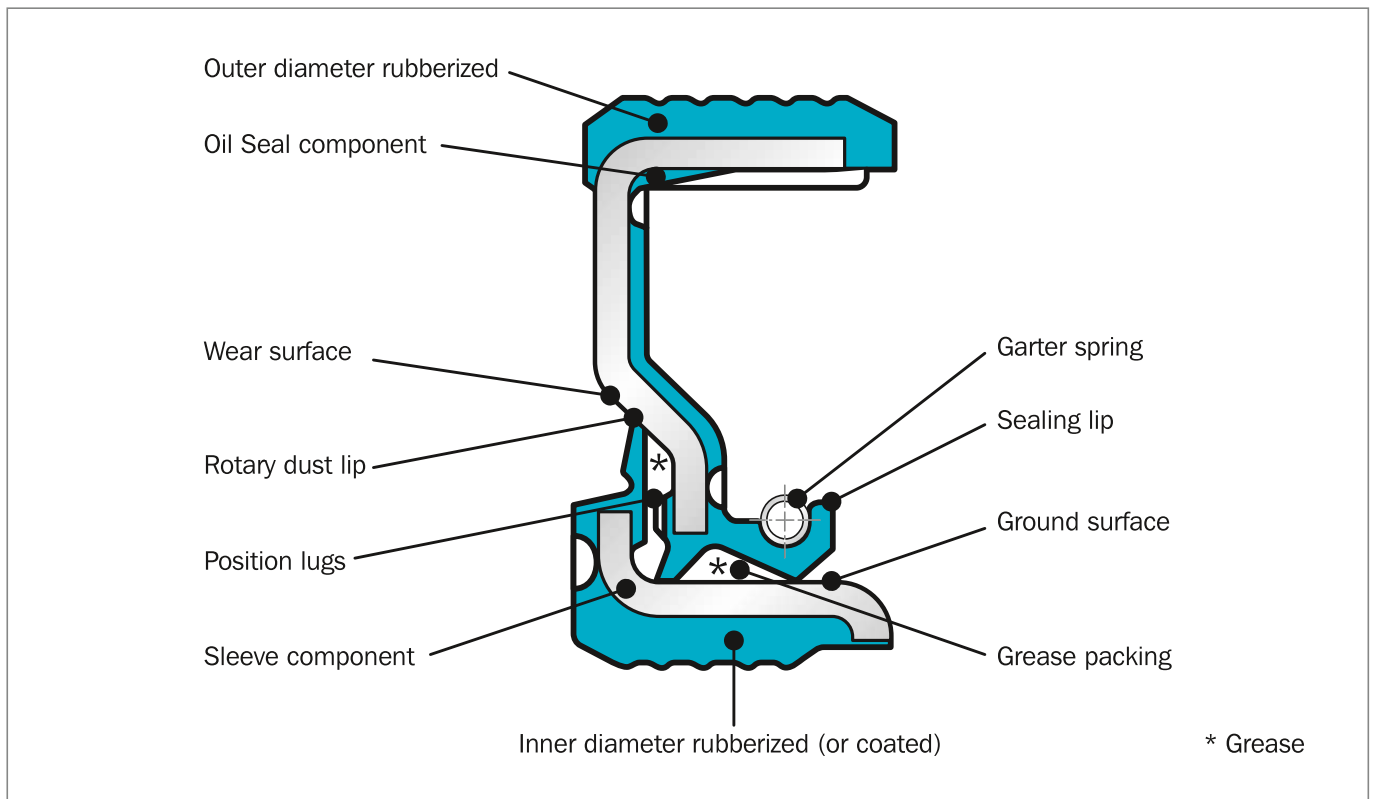

Figure 63: APJ Seal



SPECIAL FEATURES

- The overall geometry of the sealing component and the sleeve are tailored to fit the available space and assembly procedure.
- The APJ is delivered assembled and pre-packed with grease
- The APJ can usually be assembled in the application in two ways, depending on its design and the application design. It can be fitted as a unique component in the bore and in the shaft, or it can be disassembled by the customer, and then the oil seal fitted in the bore and the sleeve on the shaft, providing minimized internal friction.
- According to the type and the amount of external contaminants, the APJ is designed with tailored protection by one or more elastomeric dust lips, having an optimized geometry that can withstand the axial and radial misplacements and generate an effective sealing labyrinth.
- The static sealing between sleeve and shaft can be warranted by a rubber layer, or by a coating sealant; this last design requires less radial space, and provides an optimized dissipation of the heat generated by the sealing lip sliding.

MATERIALS AND CHEMICAL COMPATIBILITY

APJ combined rotary oil seals are designed according to customer specifications, so they can benefit from the broad range of Trelleborg Sealing Solutions elastomeric compounds and any metal required in terms of working temperatures and chemical compatibility.

- The rotary oil seal component can be made from proprietary compounds, for example FDA grades of FPM and EPDM, high temperature and high oil compatibility FKM-XploR, HNBR and NBR, very low temperatures FVMQ and FKM, able to work up to -60°C
- The materials of the metal inserts and of the energizing spring are selected between carbon steel and several grades of stainless steels, according to working environment (for example if there are FDA requirements, or chemical exposure)
- The type of grease used for internal packing is selected according to working conditions; FDA grade is available

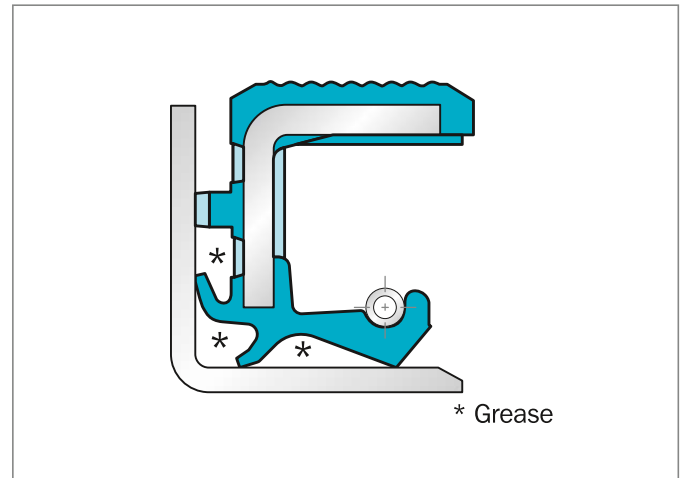

Figure 64: APJ for corrosive applications

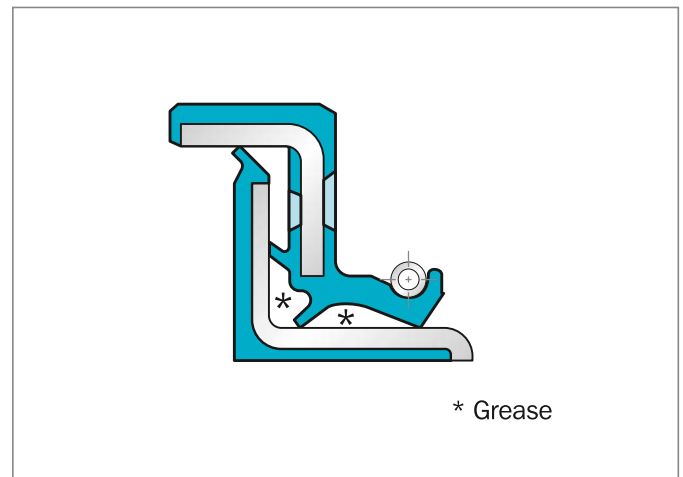

Figure 65: "Hygienic design" APJ for food applications

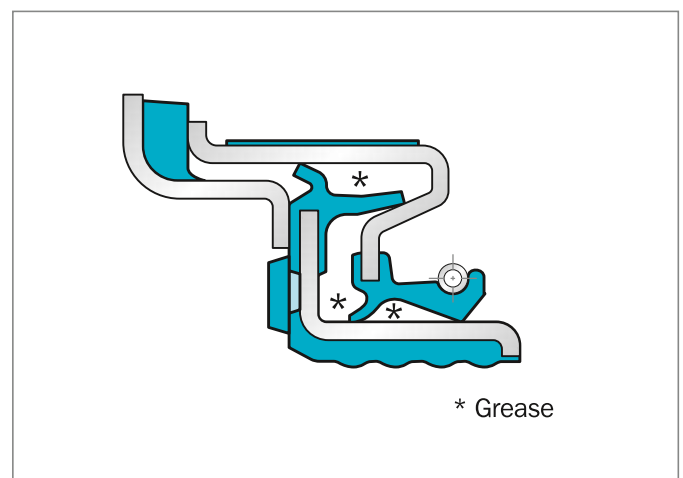

Figure 66: APJ for heavy polluted applications and axial play of the shaft